

Classic Update Series

REFER TO SHEET 2 FOR CONNECTING TO A STOCK INSTRUMENT CLUSTER. IF USING A FACTORY DASH CIRCUIT BOARD, BE SURE TO INSTALL THE WIRES AS SHOWN FOR WITH OR WITHOUT, FACTORY GAUGES.

NOTE: If you are using console gauges, connections for the console are included in 500664 kit (bag K)
After market gauge connections are included in this kit (92965220)

CONNECTOR F- Plug this connector into the mating connector on the dash harness (bag G) and connect wires as follows:

DK BLUE	Right Turn Lamp	Route this wire to the circuit board and cut to length. Install terminal C, and plug into connector D in the location shown on sheet 2, 3, 4, or 5.
LT BLUE	Left Turn Lamp	Route this wire to the circuit board and cut to length. Install terminal C, and plug into connector D in the location shown on sheet 2, 3, 4, or 5.
LT GREEN	Hi Beam Indicator Lamp	Route this wire to the high beam light socket location at the top of the instrument cluster, and cut to length. Install lamp socket B, and rivet A. Install this into the hi beam hole on the instrument cluster.
DK GREEN	Temperature Sender	Route this wire to the circuit board and cut to length. Install terminal C, and plug into connector D in the location shown on sheet 2, 3, 4, or 5.
DK BLUE	Oil Pressure Sender	Route this wire to the circuit board and cut to length. Install terminal C, and plug into connector D in the location shown on sheet 2, 3, 4, or 5. (Note: Valid only on an original warning light cluster.)
TAN	Fuel Sender	Route this wire to the circuit board and cut to length. Install terminal C, and plug into connector D in the location shown on sheet 2, 3, 4, or 5.
TAN (no printing)	Brake Lamp	Route this wire to the circuit board and cut to length. Install terminal C, and plug into connector D in the location shown on sheet 2, 3, 4, or 5.

CONNECTOR G

PINK	12v Ignition	Route this wire to the circuit board and cut to length. Install terminal C, and plug into connector D in the location shown on sheet 2, 3, 4, or 5.
GREY	Instrument Lamps	Route this wire to the circuit board and cut to length. Install terminal C, and plug into connector D in the location shown on sheet 2, 3, 4, or 5.
BLACK	Ground (Camaro)	Route this wire to the instrument cluster and cut to length. Install ring terminal E and attach to the cluster's metal housing. This will ground the housing.
	(Nova)	Route this wire to the instrument cluster and cut to length. Install terminal F, plug into connector G and install onto cluster ground. This will ground the cluster.

LOOSE WIRES

WHITE	Tachometer	<u>Used ONLY with a tachometer.</u> Plug this wire into connector F, maintaining color continuity with the white "TACH" wire on the mating dash connector.
ORANGE	Clock Feed	If using a factory Tick-Tock Tach, plug this wire into the clock location on the tach, and attach the other end to the mating connector on the dash harness.
BROWN	Alternator	<u>Used with a stock generator lamp.</u> Route this wire to the circuit board and cut to length. Install terminal C, and plug into connector F in the location shown on sheet 2, 3, 4, or 5.
BROWN	Park Lamp	<u>Used ONLY with Dakota Digital dash panels.</u> Plug this wire into connector G, maintaining color continuity with the brown "PARK LAMP" wire on the mating dash connector. Connect the other end to the gauge manufacturer's panel - DIM location. This will dim the panel lights when headlights are turned on.
PURPLE	VSS Signal lead	<u>Used ONLY with an electronic speedometer.</u> This wire will plug into connector G, maintaining color continuity with the purple wire on the mating dash connector. Connect the other end to the speedometer 'sender' terminal following the manufacturer's instructions.
YELLOW	VSS Signal ground	<u>Used ONLY with an electronic speedometer.</u> This wire will plug into connector G, maintaining color continuity with the yellow wire on the mating dash connector. Connect the other end to a good chassis ground, following the manufacturer's instructions.

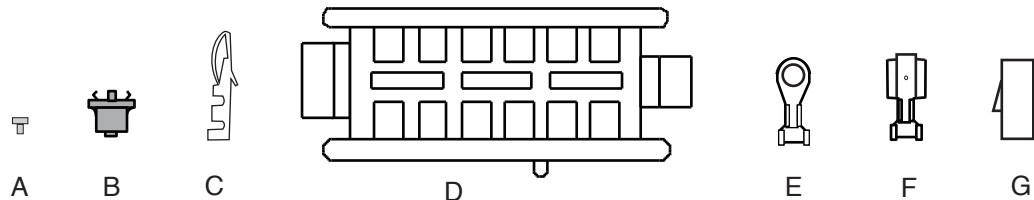

**American
Autowire**

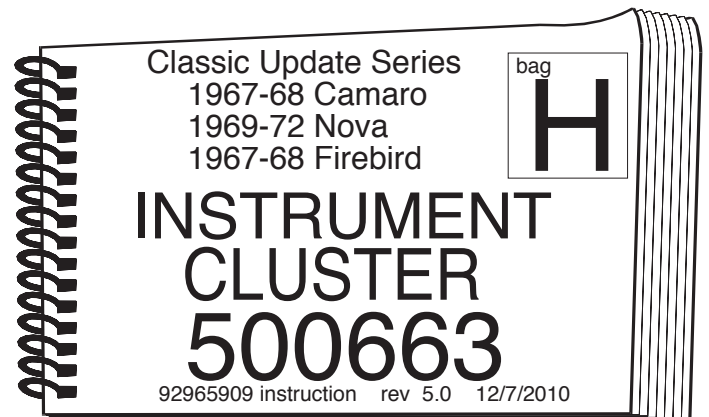

USE THIS SHEET TO CONNECT TO AN ORIGINAL 1967 **CAMARO**
 FACTORY INSTRUMENT CLUSTER WITH A CIRCUIT BOARD CONNECTION

NOTE: This kit will not support the use of a factory installed ammeter

CIRCUIT BOARD CONNECTOR
 WITHOUT CONSOLE GAUGES

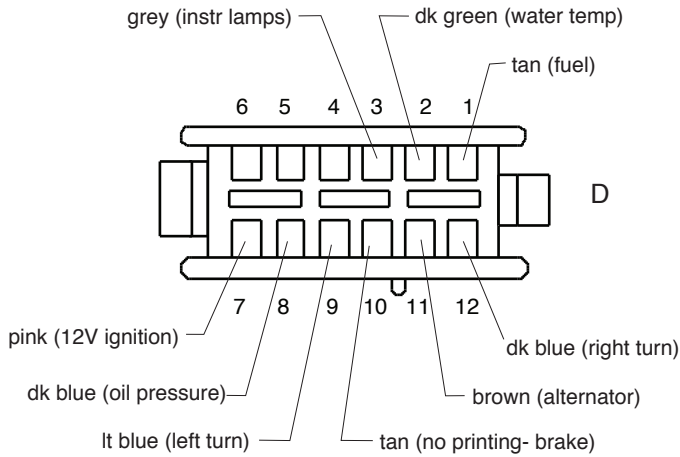

CIRCUIT BOARD CONNECTOR
 WITH CONSOLE GAUGES

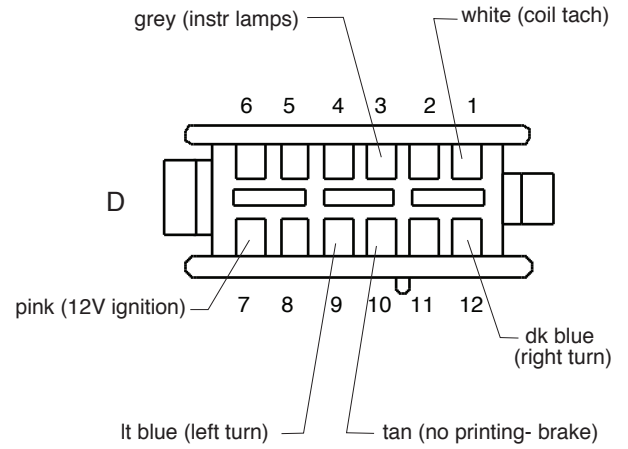

Classic Update Series

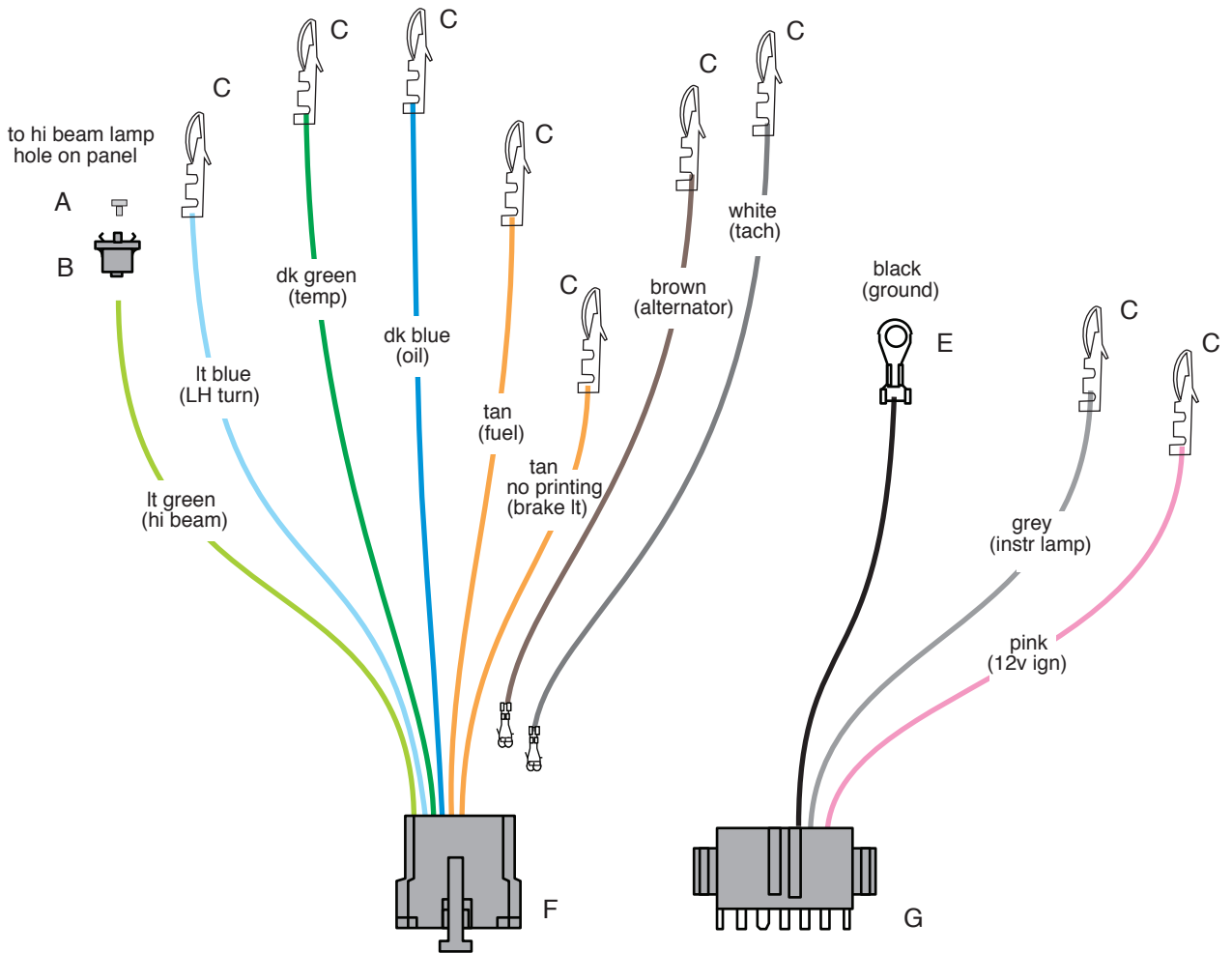

**American
 Autowire**

USE THIS SHEET TO CONNECT TO AN ORIGINAL 1968 **CAMARO**
 FACTORY INSTRUMENT CLUSTER WITH A CIRCUIT BOARD CONNECTION

NOTE: This kit will not support the use of a factory installed ammeter

CIRCUIT BOARD CONNECTOR
 WITHOUT CONSOLE GAUGES

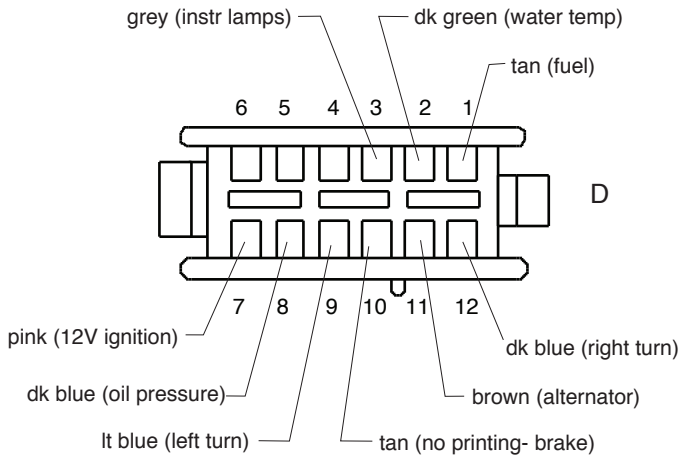

CIRCUIT BOARD CONNECTOR
 WITH CONSOLE GAUGES

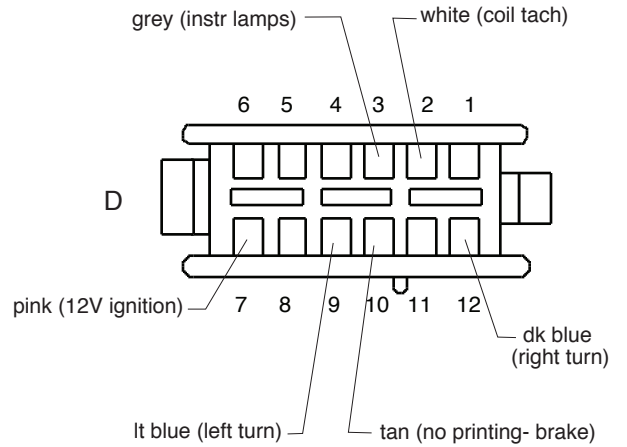

Classic Update Series

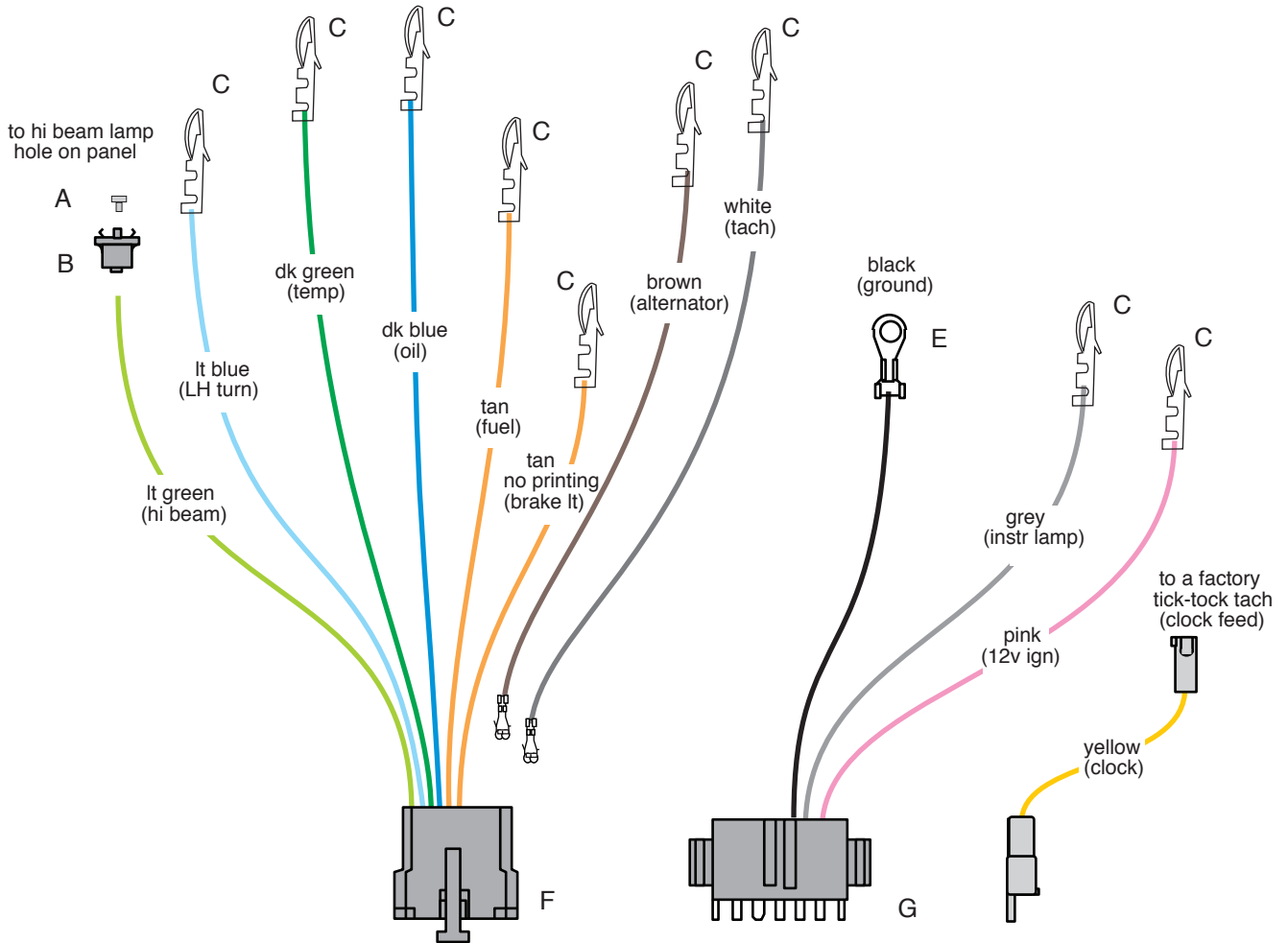

**American
 Autowire**



**USE THIS SHEET TO CONNECT TO AN ORIGINAL 1969-72 NOVA
FACTORY INSTRUMENT CLUSTER WITH A CIRCUIT BOARD CONNECTION**

NOTE: This kit will not support the use of a factory installed ammeter

**CIRCUIT BOARD CONNECTOR
WITHOUT CONSOLE GAUGES**

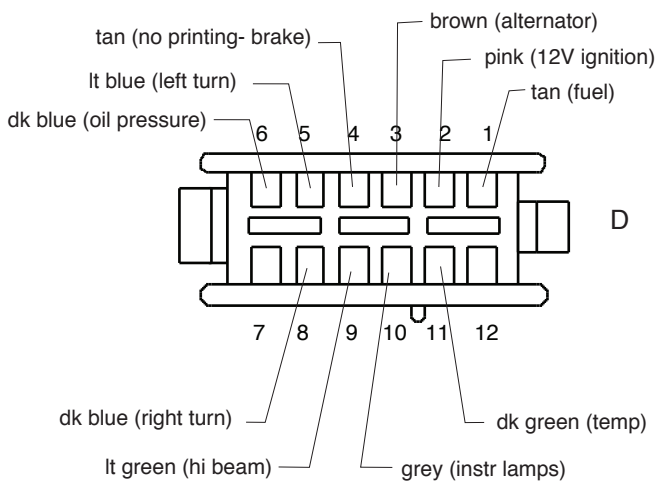

**CIRCUIT BOARD CONNECTOR
WITH CONSOLE GAUGES**

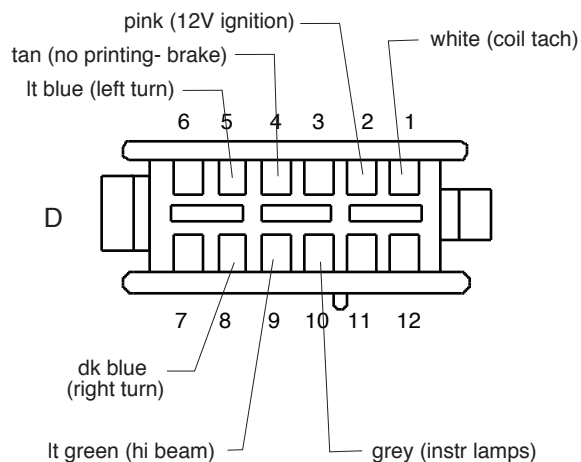

Classic Update Series

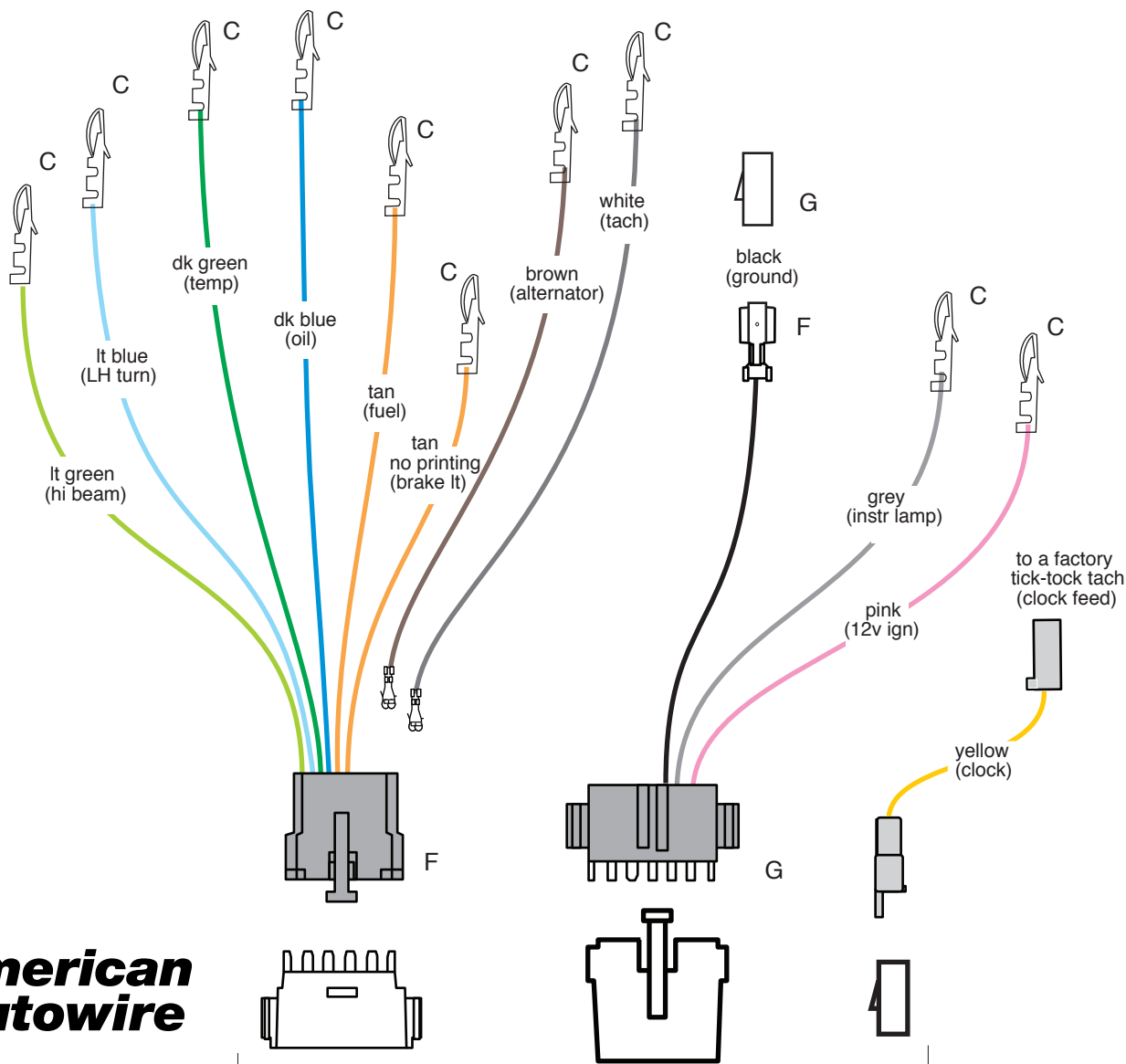

**American
Autowire**

**USE THIS SHEET TO CONNECT TO AN ORIGINAL 1967-68 FIREBIRD
FACTORY INSTRUMENT CLUSTER WITH A CIRCUIT BOARD CONNECTION**

NOTE: This kit will not support the use of a factory installed ammeter

**CIRCUIT BOARD CONNECTOR
WITHOUT GAUGES**

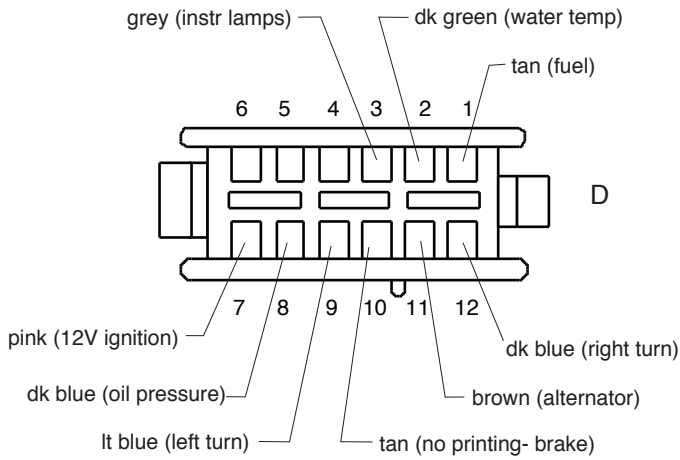

**CIRCUIT BOARD CONNECTOR
WITH GAUGES**

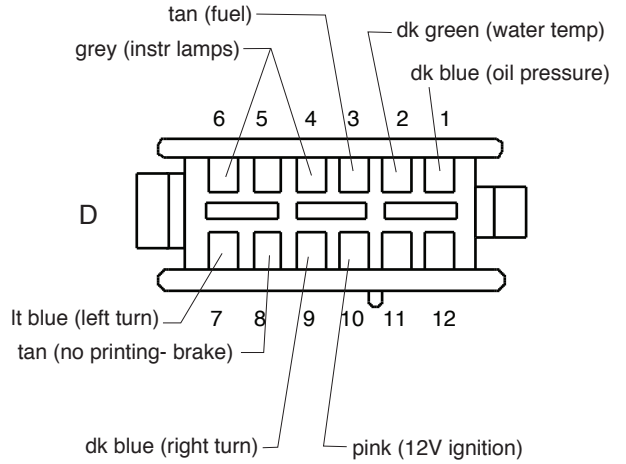

Classic Update Series

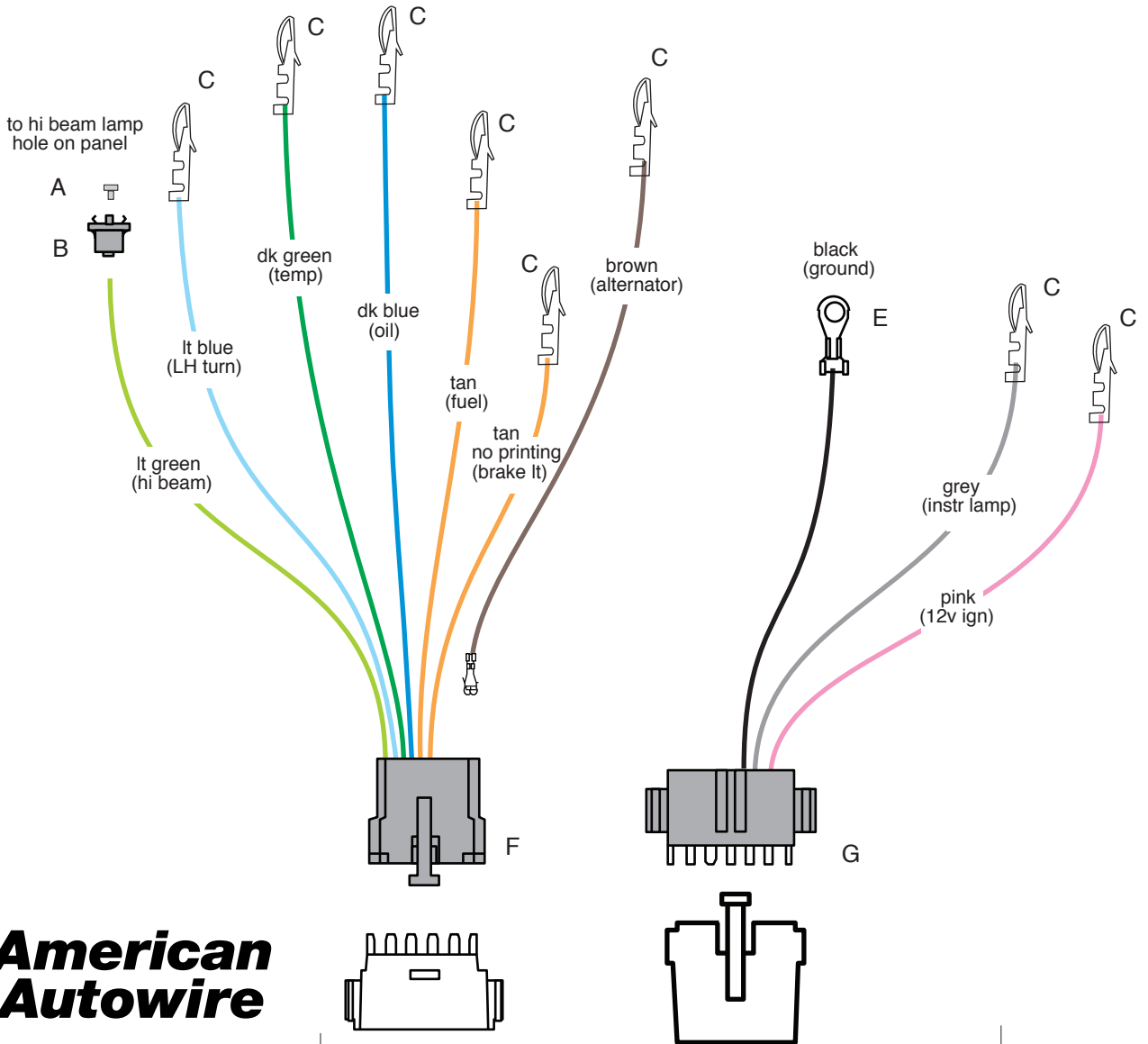

**American
Autowire**

Classic Update Series



This page Intentionally left blank