

INSTALLING THE FUSE BOX

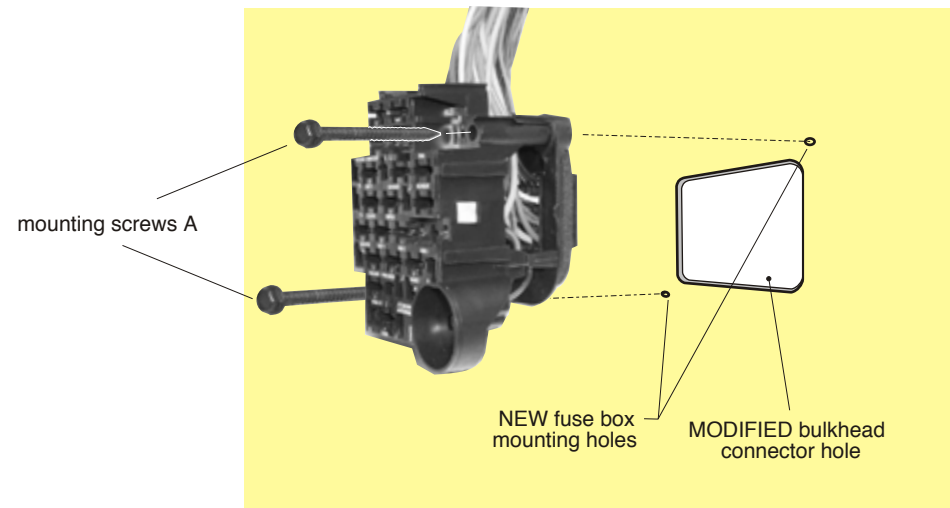

1. Locate the stock OEM bulkhead hole in the driver side of the firewall. **NOTE: You will need to modify the opening in the firewall by making it larger. See firewall template 92967369 to help with this operation. The new right hand upper mounting hole will be located where there is a raised area in the firewall very near the brake booster. The fusebox will still mount fine.**
2. Mount the fuse box with the flasher can in the bottom right corner, as shown above.
3. Using the two mounting screws A, attached the fuse panel to the firewall.

Fuse Panel Installation Instructions

Following these simple instructions will guarantee a successful installation of your American Autowire fuse panel harness.

1. Study the diagram above to familiarize yourself with the dash harness.
2. Modify your firewall opening and install the fuse box (see item #1 below left, and 92967369 template).
3. Route the dash harness using the factory support straps.
4. Make all connections as shown on the following pages of this dash harness kit.
5. Once this harness is installed, continue to bag 'H', and install the rest of the kit (bags H,J,K,L,M).



www.americanautowire.com 856-933-0801



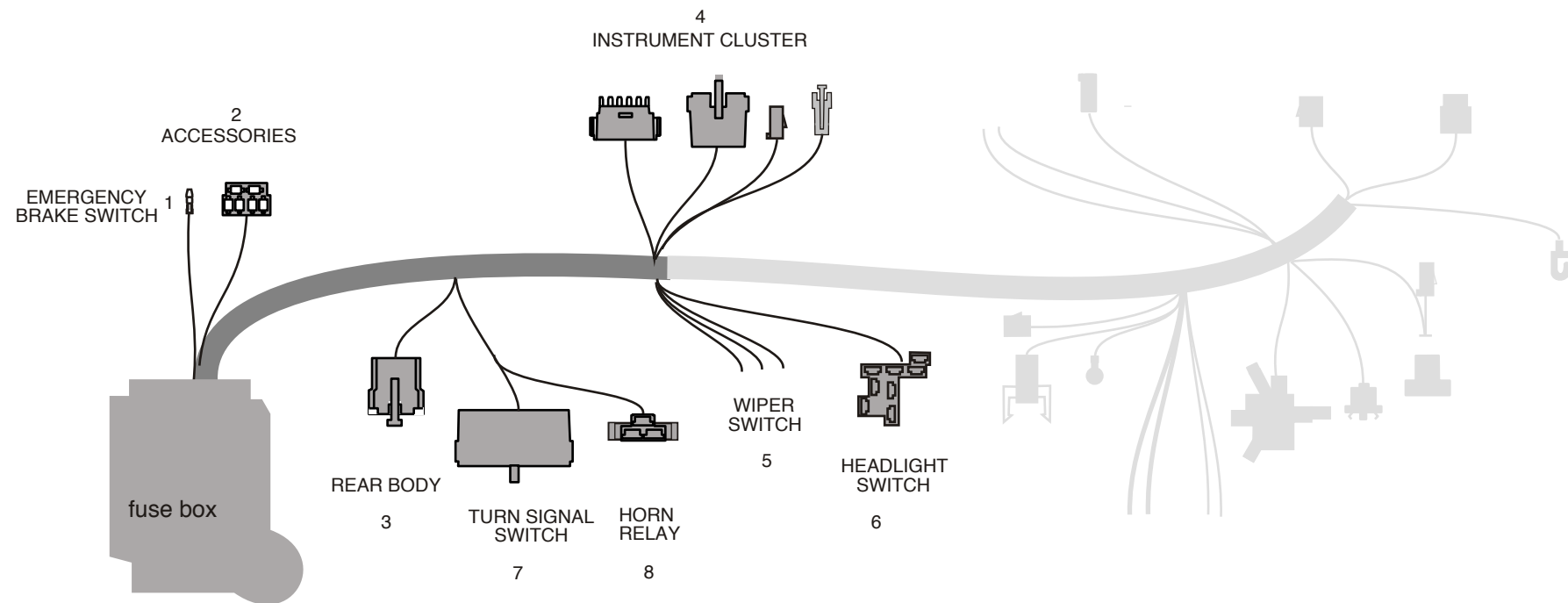

- | | | | | | | | | | | | | | | | | | | | | | | | | |
|---------------------|---|---|--|-------|--------------------------------|---------------------|---|---------------|--|-------------|--------------------------------|--|----------------------------------|-------------|---|-------------|--------------------|---|---------------------------------------|---------------|--|-----|--------------|---|
| 1 | EMERGENCY BRAKE | Tan | Connect to the emergency brake switch. This is the ground circuit for the brake switch light. | | | | | | | | | | | | | | | | | | | | | |
| 2 | ACCESSORIES | | Use the provided connector J attached and terminals as power leads for the following:
<table border="0"> <tr> <td>Fuse</td> <td>Rating</td> <td></td> </tr> <tr> <td>Dark Blue</td> <td>FUEL 15 amp</td> <td>Fused 12 volt IGNITION feed for fuel pump (may also be used to feed power to another ignition circuit)</td> </tr> <tr> <td>Orange</td> <td>BAT1 20 amp</td> <td>Fused 12 volt BATTERY feed for power seats (may also be used to feed power to another battery circuit)</td> </tr> <tr> <td>Red</td> <td>BAT2 30 amp</td> <td>Fused 12 volt BATTERY feed for power door locks (may also be used to feed power to another accessory circuit)</td> </tr> <tr> <td>Pink</td> <td>IGN1 20 amp</td> <td>Fused 12 volt IGNITION feed for cruise control (may also be used to feed power to another ignition circuit)</td> </tr> <tr> <td>Yellow</td> <td>PWRWDO 30 amp</td> <td>Fused 12 volt IGNITION feed for power windows (may also be used to feed power to another ignition circuit)</td> </tr> <tr> <td>Tan</td> <td>ACCY1 30 amp</td> <td>Fused 12 volt ACCESSORY feed (may also be used to feed power to an accessory circuit)</td> </tr> </table> | Fuse | Rating | | Dark Blue | FUEL 15 amp | Fused 12 volt IGNITION feed for fuel pump (may also be used to feed power to another ignition circuit) | Orange | BAT1 20 amp | Fused 12 volt BATTERY feed for power seats (may also be used to feed power to another battery circuit) | Red | BAT2 30 amp | Fused 12 volt BATTERY feed for power door locks (may also be used to feed power to another accessory circuit) | Pink | IGN1 20 amp | Fused 12 volt IGNITION feed for cruise control (may also be used to feed power to another ignition circuit) | Yellow | PWRWDO 30 amp | Fused 12 volt IGNITION feed for power windows (may also be used to feed power to another ignition circuit) | Tan | ACCY1 30 amp | Fused 12 volt ACCESSORY feed (may also be used to feed power to an accessory circuit) |
| Fuse | Rating | | | | | | | | | | | | | | | | | | | | | | | |
| Dark Blue | FUEL 15 amp | Fused 12 volt IGNITION feed for fuel pump (may also be used to feed power to another ignition circuit) | | | | | | | | | | | | | | | | | | | | | | |
| Orange | BAT1 20 amp | Fused 12 volt BATTERY feed for power seats (may also be used to feed power to another battery circuit) | | | | | | | | | | | | | | | | | | | | | | |
| Red | BAT2 30 amp | Fused 12 volt BATTERY feed for power door locks (may also be used to feed power to another accessory circuit) | | | | | | | | | | | | | | | | | | | | | | |
| Pink | IGN1 20 amp | Fused 12 volt IGNITION feed for cruise control (may also be used to feed power to another ignition circuit) | | | | | | | | | | | | | | | | | | | | | | |
| Yellow | PWRWDO 30 amp | Fused 12 volt IGNITION feed for power windows (may also be used to feed power to another ignition circuit) | | | | | | | | | | | | | | | | | | | | | | |
| Tan | ACCY1 30 amp | Fused 12 volt ACCESSORY feed (may also be used to feed power to an accessory circuit) | | | | | | | | | | | | | | | | | | | | | | |
| 3 | REAR BODY | | This connector will mate to the connector from the Rear Body harness found in bag L.
<table border="0"> <tr> <td>Tan</td> <td>Fuel tank sender lead</td> </tr> <tr> <td>Brown</td> <td>Tail lamp feed</td> </tr> <tr> <td>Yellow</td> <td>LH turn / brake feed</td> </tr> <tr> <td>Dark Green</td> <td>RH turn / brake feed</td> </tr> <tr> <td>Orange</td> <td>Dome / courtesy lamp feed</td> </tr> <tr> <td>White</td> <td>Dome / courtesy lamp ground</td> </tr> <tr> <td>Light Green</td> <td>Back up lamp feed</td> </tr> <tr> <td>Light Blue</td> <td>Third brake light</td> </tr> </table> | Tan | Fuel tank sender lead | Brown | Tail lamp feed | Yellow | LH turn / brake feed | Dark Green | RH turn / brake feed | Orange | Dome / courtesy lamp feed | White | Dome / courtesy lamp ground | Light Green | Back up lamp feed | Light Blue | Third brake light | | | | | |
| Tan | Fuel tank sender lead | | | | | | | | | | | | | | | | | | | | | | | |
| Brown | Tail lamp feed | | | | | | | | | | | | | | | | | | | | | | | |
| Yellow | LH turn / brake feed | | | | | | | | | | | | | | | | | | | | | | | |
| Dark Green | RH turn / brake feed | | | | | | | | | | | | | | | | | | | | | | | |
| Orange | Dome / courtesy lamp feed | | | | | | | | | | | | | | | | | | | | | | | |
| White | Dome / courtesy lamp ground | | | | | | | | | | | | | | | | | | | | | | | |
| Light Green | Back up lamp feed | | | | | | | | | | | | | | | | | | | | | | | |
| Light Blue | Third brake light | | | | | | | | | | | | | | | | | | | | | | | |
| 4 | INSTRUMENT CLUSTER DISCONNECTS | | These connectors will plug into the gauge disconnect harness from bag H. Wire identifications are described on the instruction sheets from bag H. | | | | | | | | | | | | | | | | | | | | | |
| 5 | WIPER | Black
DK Blue
Lt Blue | Ground circuit for low speed.
Ground circuit for washer.
Ground circuit for hi speed. | | | | | | | | | | | | | | | | | | | | | |
| 6 | HEADLIGHT SWITCH | Red
Orange
Brown
Yellow
Dk Green
White | 12 volt feed to switch
12 volt feed in to park/tail
Park lamp feed out
Dimmer feed
Instrument lamp feed
Dome / courtesy ground
<table border="0"> <tr> <td>BAT</td> <td>location on headlight switch</td> </tr> <tr> <td>PARK / TAIL FEED IN</td> <td>location on headlight switch. (commonly found on GM headlight switches)</td> </tr> <tr> <td>PARK LAMP OUT</td> <td>location on headlight switch.</td> </tr> <tr> <td>DIMMER FEED</td> <td>location on headlight switch.</td> </tr> <tr> <td>INSTRUMENT LAMP</td> <td>location on headlight switch.</td> </tr> <tr> <td>GROUND</td> <td>location on headlight switch.</td> </tr> </table> | BAT | location on headlight switch | PARK / TAIL FEED IN | location on headlight switch. (commonly found on GM headlight switches) | PARK LAMP OUT | location on headlight switch. | DIMMER FEED | location on headlight switch. | INSTRUMENT LAMP | location on headlight switch. | GROUND | location on headlight switch. | | | | | | | | | |
| BAT | location on headlight switch | | | | | | | | | | | | | | | | | | | | | | | |
| PARK / TAIL FEED IN | location on headlight switch. (commonly found on GM headlight switches) | | | | | | | | | | | | | | | | | | | | | | | |
| PARK LAMP OUT | location on headlight switch. | | | | | | | | | | | | | | | | | | | | | | | |
| DIMMER FEED | location on headlight switch. | | | | | | | | | | | | | | | | | | | | | | | |
| INSTRUMENT LAMP | location on headlight switch. | | | | | | | | | | | | | | | | | | | | | | | |
| GROUND | location on headlight switch. | | | | | | | | | | | | | | | | | | | | | | | |
| 7 | TURN SIGNAL SWITCH | | This harness has a connector on it for the 3-7/8 1969-1974 GM column connection used by GM and many after-market manufacturer s. If you are using a stock 1964-67 turn signal switch, remove the existing connector and terminals from your steering column and install terminals M and connector L (see diagram G) on page 3. If using a late model GM steering column or an after-market column using the 4-1/4 GM turn signal connector, replace existing connector with connector L, matching wires by color.
<table border="0"> <tr> <td>White</td> <td>12 volt feed from brake switch</td> </tr> <tr> <td>Dark Green</td> <td>RH tail lamp</td> </tr> <tr> <td>Yellow</td> <td>LH tail lamp</td> </tr> <tr> <td>Purple</td> <td>12 volt feed from turn flasher</td> </tr> <tr> <td>Brown</td> <td>12 volt feed from hazard flasher</td> </tr> <tr> <td>Dark Blue</td> <td>RH front park lamp</td> </tr> <tr> <td>Light Blue</td> <td>LH front park lamp</td> </tr> <tr> <td>Black</td> <td>Horn relay ground wire to horn switch</td> </tr> </table> | White | 12 volt feed from brake switch | Dark Green | RH tail lamp | Yellow | LH tail lamp | Purple | 12 volt feed from turn flasher | Brown | 12 volt feed from hazard flasher | Dark Blue | RH front park lamp | Light Blue | LH front park lamp | Black | Horn relay ground wire to horn switch | | | | | |
| White | 12 volt feed from brake switch | | | | | | | | | | | | | | | | | | | | | | | |
| Dark Green | RH tail lamp | | | | | | | | | | | | | | | | | | | | | | | |
| Yellow | LH tail lamp | | | | | | | | | | | | | | | | | | | | | | | |
| Purple | 12 volt feed from turn flasher | | | | | | | | | | | | | | | | | | | | | | | |
| Brown | 12 volt feed from hazard flasher | | | | | | | | | | | | | | | | | | | | | | | |
| Dark Blue | RH front park lamp | | | | | | | | | | | | | | | | | | | | | | | |
| Light Blue | LH front park lamp | | | | | | | | | | | | | | | | | | | | | | | |
| Black | Horn relay ground wire to horn switch | | | | | | | | | | | | | | | | | | | | | | | |
| 8 | HORN RELAY | Plug the horn relay (found in the fuse bag) into this connector.
Red
Black
Green | 12 volt battery
Relay ground circuit (to steering column)
Triggered 12 volts to horn | | | | | | | | | | | | | | | | | | | | | |

Wiper switch connections
In each case install the female terminal supplied and apply connector shown.

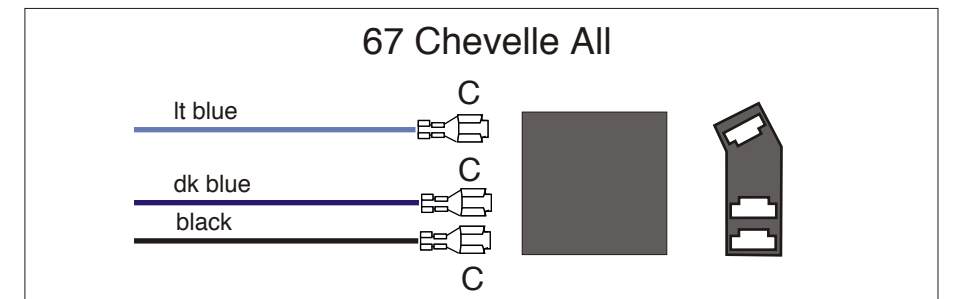
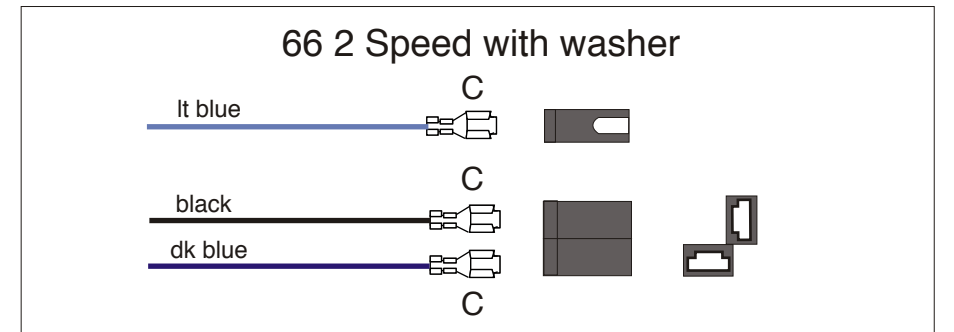
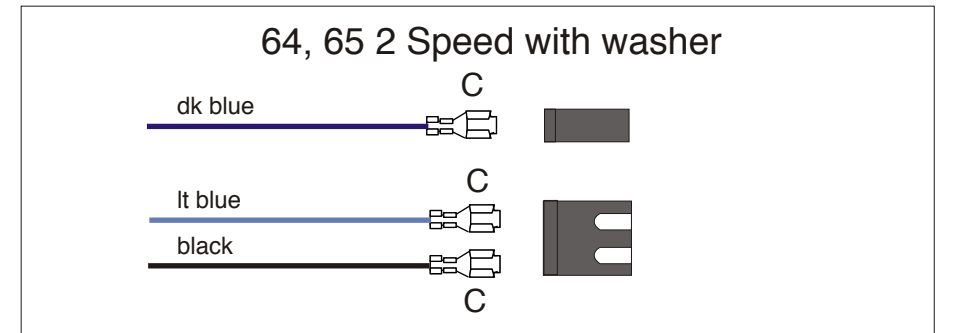
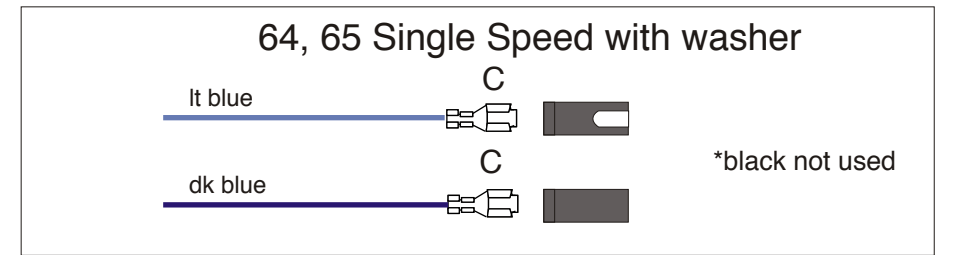

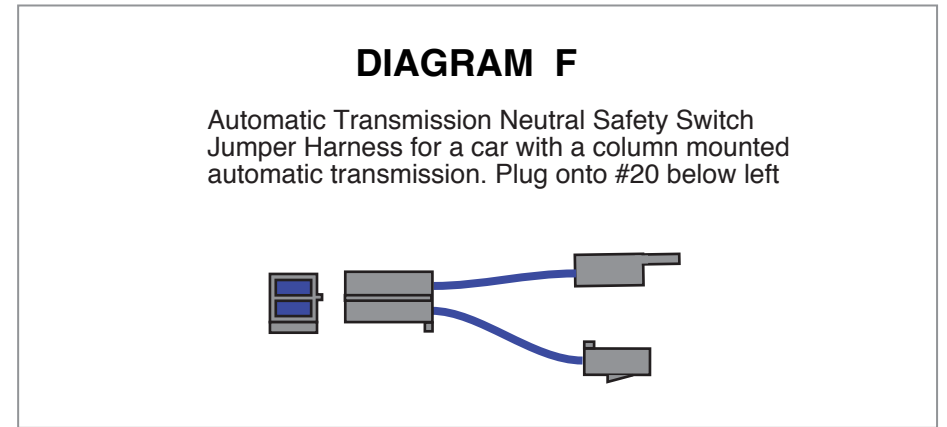
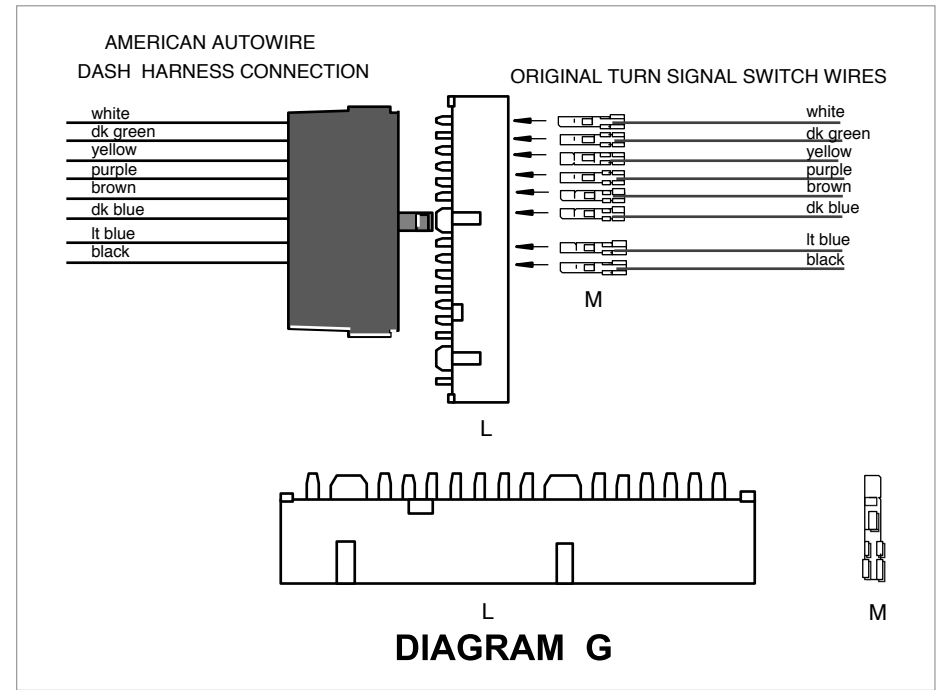
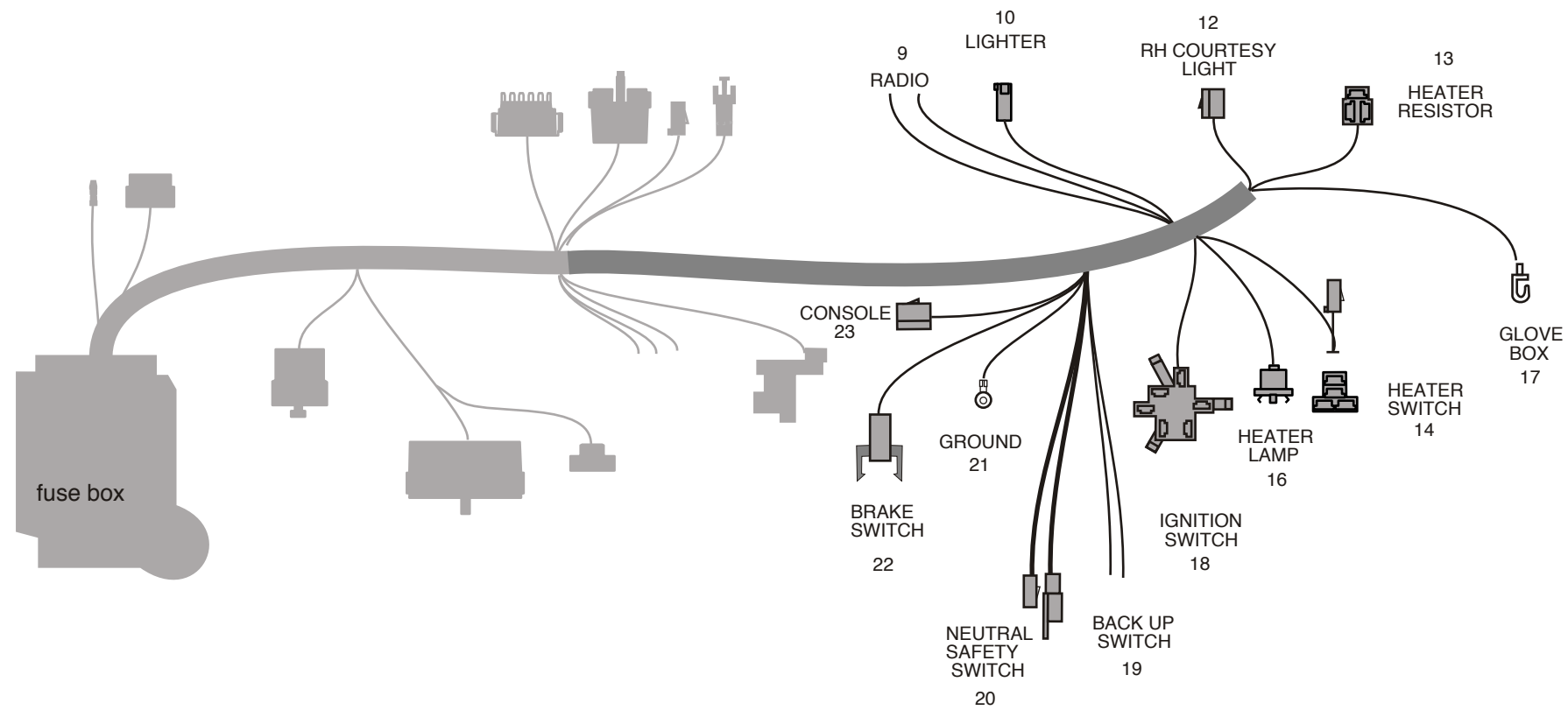

9	RADIO	Tan	Radio accessory feed.
		Yellow	Radio 12 volt clock lead (battery feed)
10	LIGHTER	Orange	Connect to lighter. (battery feed)
11	CONSOLE CONNECTION	These wires are for use on a console vehicle. For wire functions, refer to bag K, 500664.	
12	RH COURTESY LAMP	Plug this connector into the mating connector from the courtesy lamp kit bag N, 500708.	
		Orange	12 volt battery feed to lamp
		White	Ground circuit for lamp
13	HEATER RESISTOR	Plug this connector into the factory heater resistor located on top of the heater box of a non A/C car.	
14	HEATER SWITCH	Plug this connector into the factory heater switch.	
		Brown	12 volt accessory feed to heater / ac switch (if using aftermarket a/c, use the short brown wire as the accessory feed wire to a/c harness.)
		Yellow	Heater resistor
		Lt Blue	Heater resistor
		Orange	Heater resistor
16	HEATER LAMP	Gray	Heater lamp
17	GLOVE BOX LIGHT	Orange	Connect to the original factory glove box lamp switch. If not using, just unplug and tape back.
18	IGNITION SWITCH	Red	12 volt battery feed
		Pink	12 volt ignition feed
		Brown	12 volt accessory feed
		Purple	12 volt starter feed
19	BACK UP SWITCH	Connect these wires to the back up switch on the column or console shifter.	
		Pink	12 volt ignition feed 'in' to back up lamp switch
		Lt Green	12 volt feed 'out' to back up lamps
20	NEUTRAL SAFETY SWITCH	If using a column mounted automatic transmission, plug these wires into the NSS jumper harness in Diagram F at the right, then plug onto the neutral safety switch on the column. If using with console mounted automatic transmission, plug these wire into the NSS wires on the console harness. If using a manual transmission, plug these wires together.	
		Purple	12 volt feed 'in' to neutral safety switch.
		Purple	12 volt feed 'out' to starter
21	GROUND	Black	Connect to a good chassis ground.
22	BRAKE SWITCH	Plug this connector into the factory brake switch.	
		Orange	12 volt feed 'in' to switch.
		White	12 volt feed 'out' to steering column switch.
		Lt Blue	12 volt feed 'out' to third brake light.
23	CONSOLE	Plug into console extension 500988 where applicable.	
		Orange	12 volt battery feed
		Grey	Console illumination lamp
		White	Courtesy ground

THIS PAGE HAS BEEN
INTENTIONALLY LEFT BLANK

