

**American  
Autowire**

1964-67 Chevelle

bag  
**J**

Classic Update Series  
**ENGINE KIT  
500982**

92968182 instruction rev. 2.0 8/26/2015

TEMPORARILY, PLUG THE MAIN BULKHEAD CONNECTOR FROM THIS KIT INTO THE MATING CONNECTOR ON THE DASH BULKHEAD CONNECTOR ( LOCATED UNDER THE MASTER CYLINDER) Note: This will be unbolted to install the front light harness later.

**BULKHEAD CONNECTOR WIRES:**

- |         |                       |  |
|---------|-----------------------|--|
| RED     | (12V BATTERY)         | Route this wire to the starter solenoid and cut to length. Install terminal B and solder. Plug into connector N.   |
| BROWN   | (fuse-link wire)      | Connect to the battery stud on the starter solenoid, and plug the other end into the RED wire above.   |
| PURPLE  | (STARTER SOLENOID)    | Route to the starter solenoid and cut to length. Install rubber sleeve E and ring D. Connect to the 'S' terminal on solenoid.  |
| DK BLUE | (OIL PRESSURE SENDER) | Connect this wire to the oil pressure sending unit. Using terminal P or terminal C with connector A.   |
| ORANGE  | (HEAT / AIR)          | If using after-market air conditioning, remove this wire. If using a stock heater only system, route this wire to the heater blower, cut to length. Install terminal C and connector A and plug into the blower unit.  |
| PINK    | (12V IGNITION)        | If using an HEI distributor, or after-market ignition system which requires a 12V feed:<br>Route the PINK wire to the coil and trim to length. Install terminal C and connector G, and plug into distributor cap BAT location.<br>If using a points type ignition system which required reduced voltage:<br>Route the PINK wire to the ignition feed side of the ballast resistor. Connect the loose piece YELLOW wire to the R terminal on the starter and connect the other end to the coil side of the ballast resistor (not included). Connect a piece of left over PINK wire to the coil side of the ballast resistor and route the to the distributor coil + side. |
| WHITE   | (COIL-TACH)           | Route this wire to he coil and trim to length. if using an HEI distributor, terminal B and connector F are included for connection. Plug into the TACH location or negative side of coil..   |

**ALTERNATOR**

- |           |                     |   |
|-----------|---------------------|---|
| HEAVY RED | (AMERICAN AUTOWIRE) | Connect the blue fuse link wire to the battery stud on the starter solenoid. Route the other end to the alternator and trim to length. Install boot L and terminal M and connect to the battery stud on the alternator.                               |
| SMALL RED |                     | Send the ring terminal end of this wire through boot L (as shown on sheet 1) and connect to the battery stud on alternator. Do not plug the connector into the alternator yet, the exciter wire will be added when the front light wires are install. |

REMAINING LOOSE WIRES: These wires will be used only if you are using and ECM module which is located in the engine compartment, or if you are using and electronic speedometer.

- |        |   |  |
|--------|---|--|
| RED    | (12V BATTERY)   | Used on ECM module which is mounted in the engine compartment. Plug this wire into the firewall bulkhead connector, at the location shown on sheet 1. Route the other end to the ECM harness, battery feed in. |
| PINK   | (12V IGNITION)  | Used on ECM module which is mounted in the engine compartment. Plug this wire into the firewall bulkhead connector, at the location shown on sheet 1. Route the other end to the ECM harness, ignition feed in |
| PURPLE | Used on vehicles which have an electronic speedometer. Route this wire to the vehicle speed sensor and connect to the signal lead.  |  |
| YELLOW | Used on vehicles which have an electronic speedometer. <u>Twist this wire with the purple wire above to assure proper shielding.</u> Connect this wire to the vehicle speed sensor ground lead. |  |

Once the main connector has all of it's wires plugged in, the connector cavities should be sealed with di-electric grease on the terminals. Also, to assure a moisture resistant seal, silicone can be applied to seal the outside of the connector.

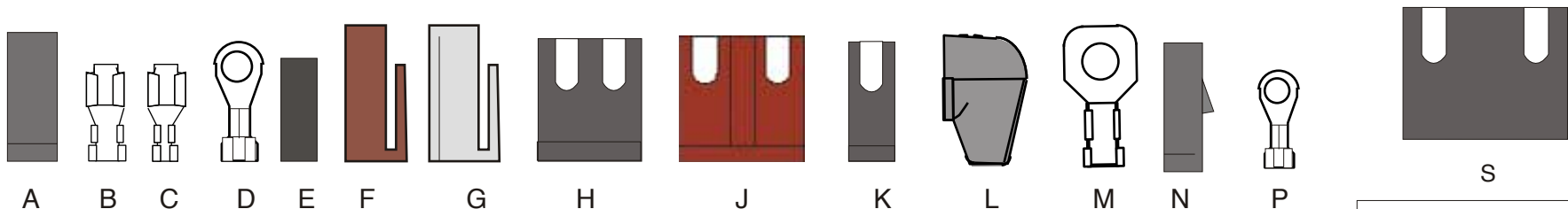

**ENGINE KIT**  
**500982**  
92968182 instruction rev. 2.0 8/26/2015

The following wires are for use on a stock wiper system. If using an after-market wiper system, follow the manufacturer's instructions.

BLACK	(WIPER LOW SPEED)	Route to the wiper motor and trim to length. Install terminal C.
DK BLUE	(WIPER WASHER)	Route this wire to the wiper motor and trim to length. Install terminal C.
LT BLUE	(WIPER HI SPEED)	Route this wire to the wiper motor and trim to length. Install terminal C.
WHITE	(WIPER ACC)	Route this wire to the wiper motor and trim to length. Using terminal B, double and solder with the cut off portion and install terminal C on the end of the cut off portion.

Use the drawings and photos below to install the appropriate connectors for your application.

### 64-65 Single Speed with washer

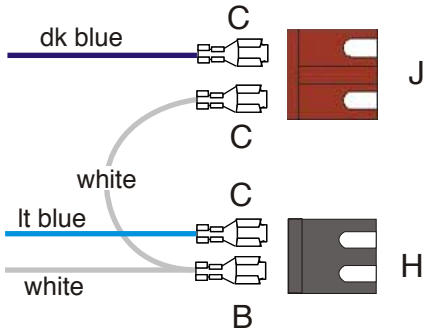

### 66-67 Chevelle All

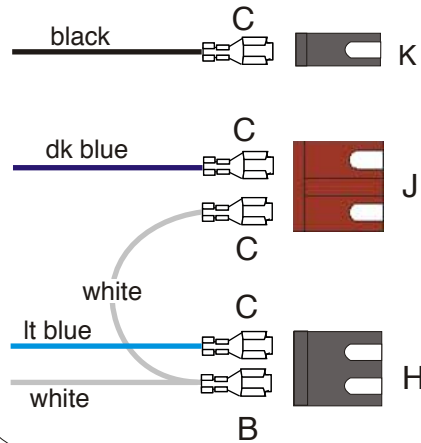

### 66-67 Chevelle 2 spd. connection



### 64-65 2 Speed with washer

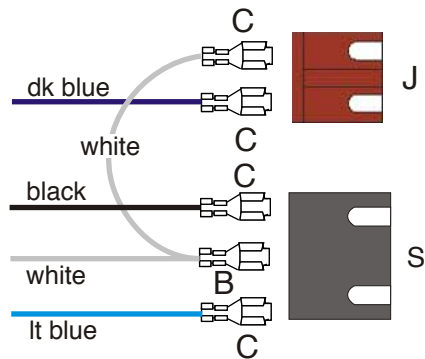

### 64-65 Chevelle 2 spd. connection

NOTE: The black with yellow stripe wire in the photo is the same as the AAW white wire.



**ENGINE KIT**  
**500982**

92968182 instruction rev. 2.0 8/26/2015

**THIS PAGE HAS BEEN  
INTENTIONALLY LEFT BLANK**

**ENGINE KIT  
500982**

92968182 instruction rev. 2.0 8/26/2015