

Classic Update Series

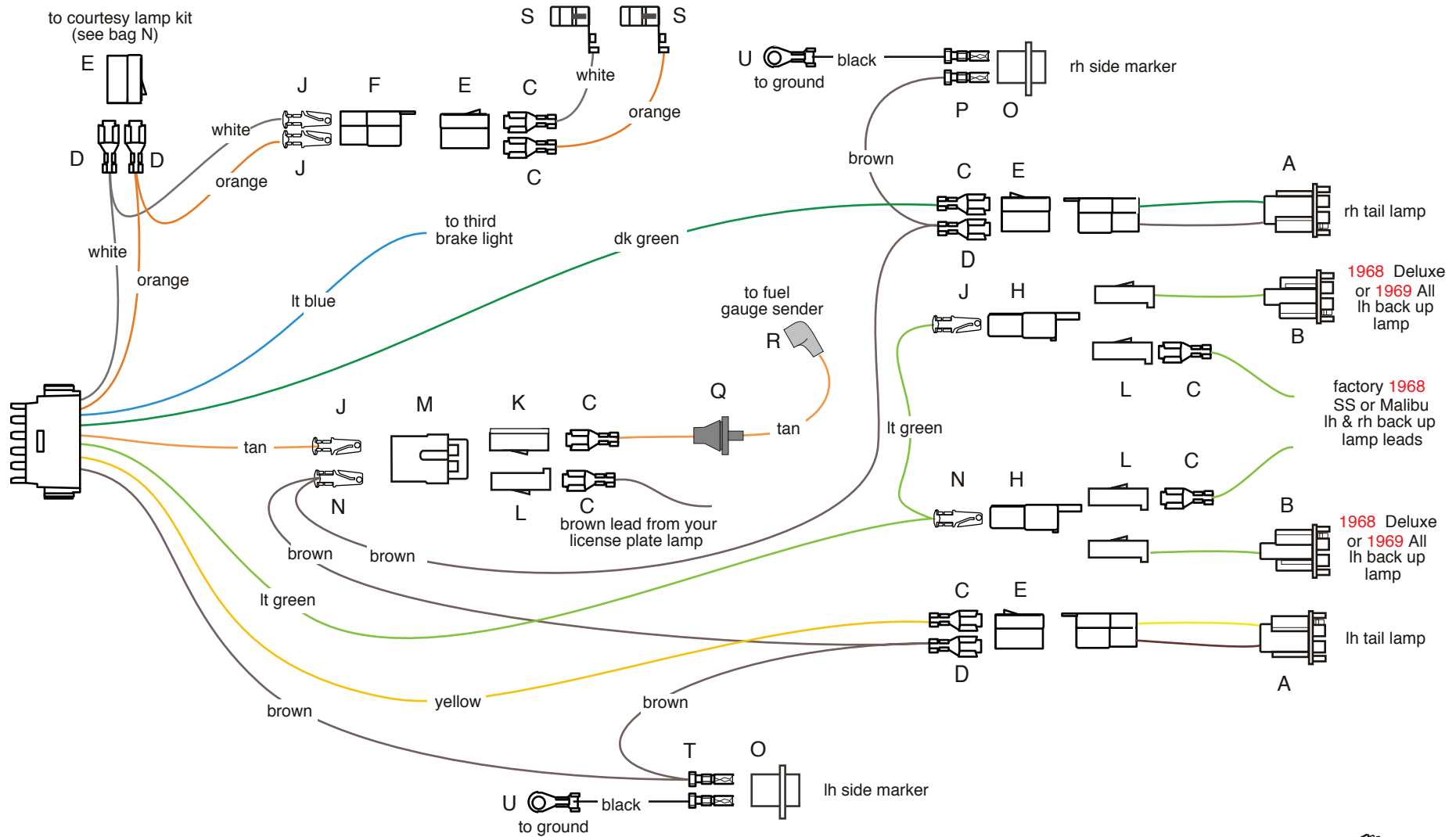

1968-69 Chevelle coupe, convertible, and sedan models



American Autowire

800-482-9473

Classic Update Series











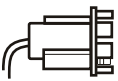
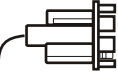

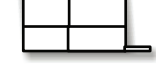

bag **M**

REAR BODY KIT

510164

92969369 instruction rev 0.0 1/15/2010

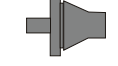
1968-69 Chevelle Coupe, Convertible, and Sedan models

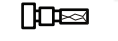
A		Connect the main connector to the mating connector on the dash harness 510160 bag G. Route this harness along door sill and into the trunk. LIGHT BLUE TAN	Third brake light Fuel signal	Connect to the third brake lamp, if equipped. Route this wire to the rear panel of the trunk (near the trunk lock) and trim to length. Install terminal J and plug into connector M as shown on sheet 1.
B		TAN	Fuel Tank lead	Plug the rubber end of wire R onto the sending unit at the fuel tank. Slide grommet Q onto the wire with the narrow end of the cone shaped grommet pointing toward the trunk floor, route the other end of this wire up through the factory hole in the trunk floor and snap the grommet into place in that hole. Route the loose end of this wire over to connector M, cut to length, install terminal C and plug into connector K as shown on sheet 1. Plug the assembled lead into connector M to complete the fuel tank sender connection.
C				
D				
E		BROWN	Running lamps	Route this wire to the LH side marker lamp, trim to length, double this wire with the cut off portion, install terminal T and plug into lamp socket O as shown on sheet 1. Route the loose end of this brown wire to the LH tail lamp, cut to length, double this wire with the cut off portion, install terminal D and plug into connector E in the location shown on sheet 1. Route the loose end of this brown wire to the license lamp area, cut to length, double this wire with the cut off portion, install terminal N and plug into connector M in the location shown on sheet 1. Route the loose end of this brown wire to the RH tail lamp, cut to length, double this wire with the cut off portion, install terminal D and plug into connector E in the location shown on sheet 1. Route the loose end of this brown wire to the RH side marker lamp, cut to length, install terminal P and plug into lamp socket O as shown on sheet 1.
F				
H				
J		BLACK	(New terminal C and connector L have been provided for your license lamp lead in case your original was cut or damaged.) Side Marker Ground	There are two loose black wire assemblies U in this kit. Plug one into each of the rear side marker lamp sockets O and route the loose end with the ring terminal to the rear panel support (near the trunk lock assembly) and attach them into the sheet metal.
K		YELLOW	LH Stop / Tail	Route this wire to the LH tail lamp, cut to length, install terminal C and plug into connector E as shown on sheet 1. Plug LH pigtail A (yellow and brown wires) into this connection to complete the LH stop and tail connection.
L		DK GREEN	RH Stop / Tail	Route this wire to the RH tail lamp, cut to length, install terminal C and plug into connector E as shown on sheet 1. Plug RH pigtail A (dk green and brown wires) into this connection to complete the RH stop and tail connection.
M		LIGHT GREEN	Back up lamp feed	Route this wire to the LH back up lamp, cut to length, double this wire with the cut off portion, install terminal N and plug into connector H as shown on sheet 1. Route the loose end of this lt green wire to the RH back up lamp, cut to length, install terminal J and plug into connector H as shown on sheet 1.
N				
O				
P		WHITE	Courtesy ground	At the driver's side kick panel area, cut this wire, double it with the cut off portion using terminal D and plug into connector E maintaining color continuity with the mating connector in the courtesy lamp kit (bag N). If you are using a dome lamp, route the loose end of this wire to the rear pillar area of the trunk, cut to length, install terminal J and plug into connector F in location shown on sheet 1. (Note: a factory dome lamp harness will also plug into this connector if you are not replacing the headliner at this time.) Install the loose white wire S (supplied with terminal installed) into the dome lamp housing. Route this wire to connector F (on white wire) location, trim to length, install terminal C and into plug connector E maintaining color continuity with the white wire in connector F.
Q				
R				
S		ORANGE	Courtesy Lamp Feed	At the driver's side kick panel area, cut this wire, double it with the cut off portion using terminal D and plug into connector E maintaining color continuity with the mating connector in the courtesy lamp kit (bag N). If you are using a dome lamp, route the loose end of this wire to the rear pillar area of the trunk, cut to length, install terminal J and plug into connector F in location shown on sheet 1. (Note: a factory dome lamp harness will also plug into this connector if you are not replacing the headliner at this time.) Install the loose orange wire S (supplied with terminal installed) into the dome lamp housing. Route this wire to connector F (on orange wire) location, trim to length, install terminal C and plug into connector E maintaining color continuity with the orange wire in connector F.
T				
U	