

### INSTALLING THE FUSE BOX

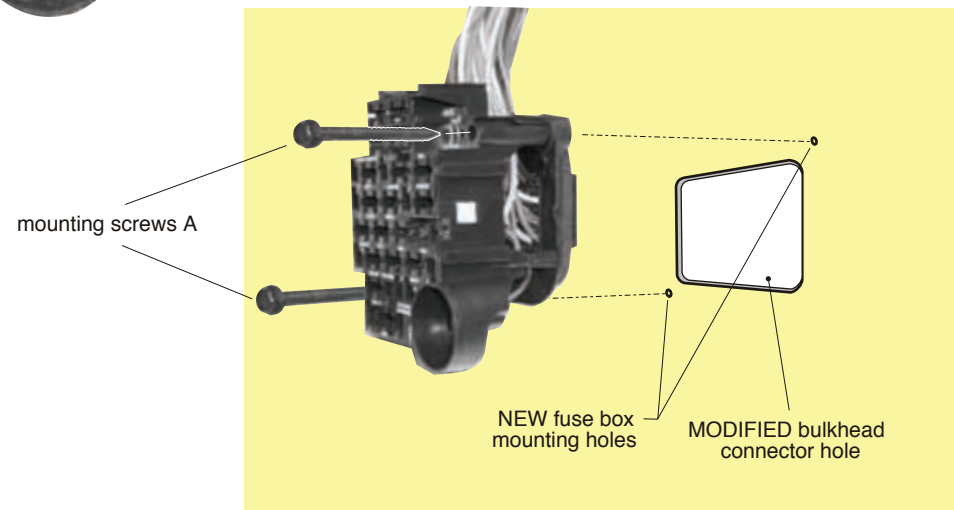

1. Locate the stock OEM bulkhead hole in the driver side of the firewall. **NOTE: You will need to modify the opening in the firewall by making it larger. See firewall template 92967369 to help with this operation. The new right hand upper mounting hole will be located where there is a raised area in the firewall. The fusebox will mount fine.**
2. Mount the fuse box with the flasher can in the bottom right corner, as shown above.
3. Using the two mounting screws A, attach the fuse panel to the firewall.

### Fuse Panel Installation Instructions

Following these simple instructions will guarantee a successful installation of your American Autowire fuse panel harness.

1. Study the diagram above to familiarize yourself with the dash harness.
2. Modify your firewall opening and install the fuse box (see item #1 below left, and 92967369 template).
3. Route the dash harness using the factory support straps.
4. Make all connections as shown on the following pages of this dash harness kit.
5. Once this harness is installed, continue to bag 'H', and install the rest of the kit (bags H,J,K,L,M,N).



www.americanautowire.com 856-933-0801



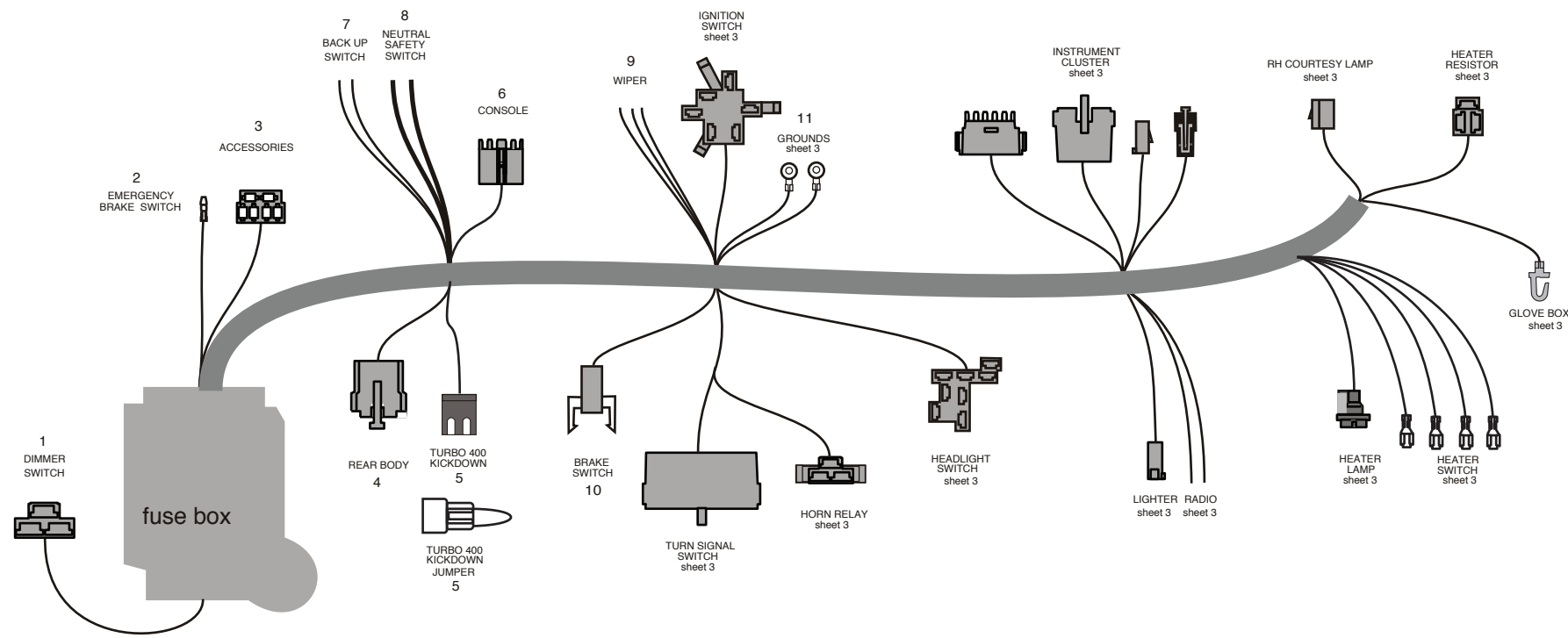

- 1 DIMMER SWITCH
- 2 EMERGENCY BRAKE SWITCH
- 3 ACCESSORIES
- 4 REAR BODY
- 5 TURBO 400 KICKDOWN
- 6 CONSOLE
- 7 BACK UP LAMP SWITCH
- 8 NEUTRAL SAFETY SWITCH
- 9 WIPER SWITCH
- 10 BRAKE LIGHT SWITCH
- 11 GROUNDS

This connector will mate to the floor mounted dimmer switch.  
 Yellow 12 volt feed into dimmer switch from H/L switch  
 Light Green 12 volt feed out to high beam H/L  
 Tan 12 volt feed out to low beam H/L

Connect to the emergency brake switch. This is the ground circuit for the brake warning switch lamp.

Use the provided connector that is plugged into the dash harness along with the loose terminals in the loose piece parts kit to connect power leads for the following:

| Fuse   | Rating | Description   |
|--------|--------|---|
| FUEL   | 15 amp | Fused 12 volt IGNITION feed for fuel pump (may also be used to feed power to another ignition circuit)        |
| BAT1   | 20 amp | Fused 12 volt BATTERY feed for power ats (may also be used to feed power to another battery circuit)          |
| BAT2   | 30 amp | Fused 12 volt BATTERY feed for power door locks (may also be used to feed power to another accessory circuit) |
| IGN1   | 20 amp | Fused 12 volt IGNITION feed for cruise control (may also be used to feed power to another ignition circuit)   |
| PWRWDO | 30 amp | Fused 12 volt IGNITION feed for power windows (may also be used to feed power to another ignition circuit)    |
| ACCY1  | 30 amp | Fused 12 volt ACCESSORY feed (may also be used to feed power to an accessory circuit)                         |

This connector will mate to the connector from the Rear Body harness found in bag L.

- Tan Fuel tank sender lead
- Brown Tail lamp and tag lamp feed
- Yellow LH turn / brake feed
- Dark Green RH turn / brake feed
- Orange Dome / courtesy lamp feed
- White Dome / courtesy lamp ground
- Light Green Back up lamp feed
- Light Blue Third brake light

On 64, 66, & 67 cars, plug this connector onto the transmission kickdown switch at the gas pedal. On 65 cars, plug the loose piece jumper onto this connector as the kickdown switch is located outside the car at the carburetor. The final connection to the transmission is addressed in the engine kit, 510191, bag J.

12 volt ignition power feed into switch  
 Switched 12 volt feed out to transmission solenoid

Plug the console harness 510195, bag K onto this connector if your car has a factory console. Follow the directions in bag K to complete your console connections.

- Orange 12 volt battery power feed for console courtesy lamp
- White Switched ground for console courtesy lamp
- Gray Transmission indicator lamp power
- Black Ground for transmission indicator lamp

Connect these wires to your back up lamp switch.

- Light Green 12 volt feed out to back up lamps
- Pink 12 volt ignition feed into back up lamp switch

Connect these wires to your neutral safety switch or together if you are using a manual transmission with out an NSS.

- Purple 12 volt feed in from ignition switch
- Purple Switched 12 volt feed out to starter solenoid

Connect these wires to your wiper/washer switch depending on the year and application of your vehicle using the detailed figures to the right on this page (page 2).

- Black Ground circuit for low speed
- Dk Blue Ground circuit for washer
- Lt Blue Ground circuit for hi speed

Plug this connector onto your factory stop lamp switch.

- Orange 12 volt fused battery feed to stop lamp switch
- White 12 volt out to turn signal switch
- Light Blue 12 volt out to third brake lamp

Connect to the dash frame, steering column saddle, or any other good known chassis ground.  
 Cluster and dash lamp grounds

**Wiper switch connections as viewed looking into the connector.**  
 In each case, install the supplied female terminals C to each of the wires and install the completed wire and terminal leads into the appropriate plastic connectors for the correct application for your car.

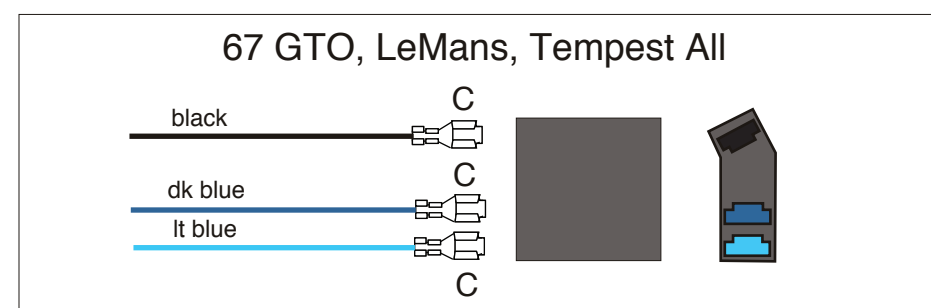
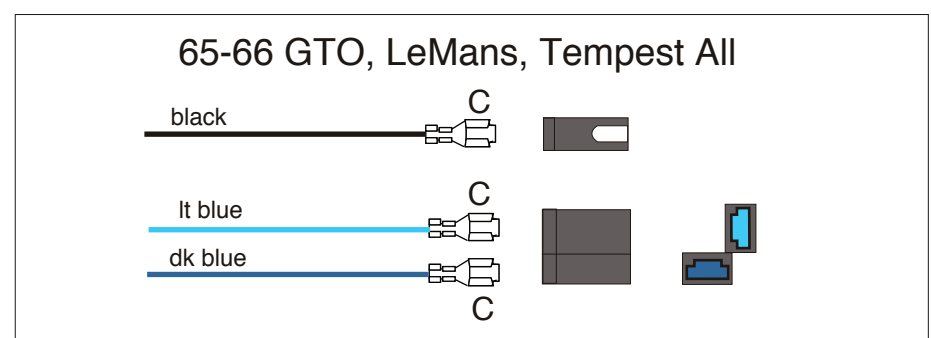
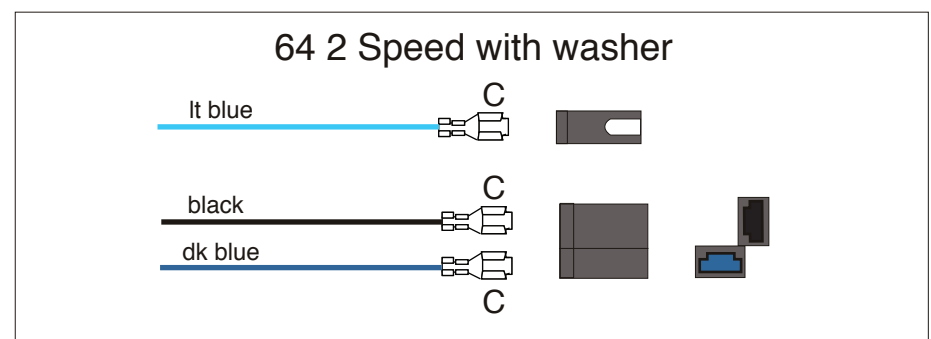
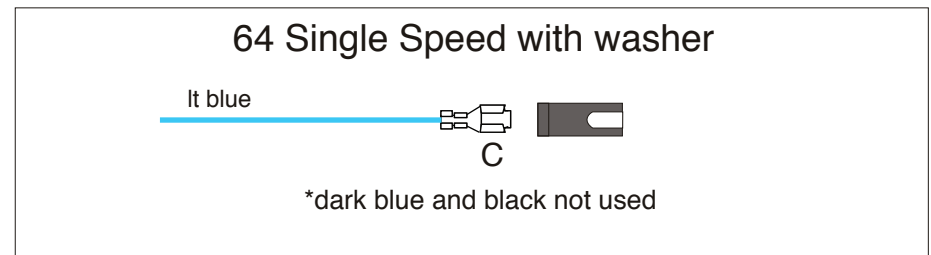

www.americanautowire.com 856-933-0801



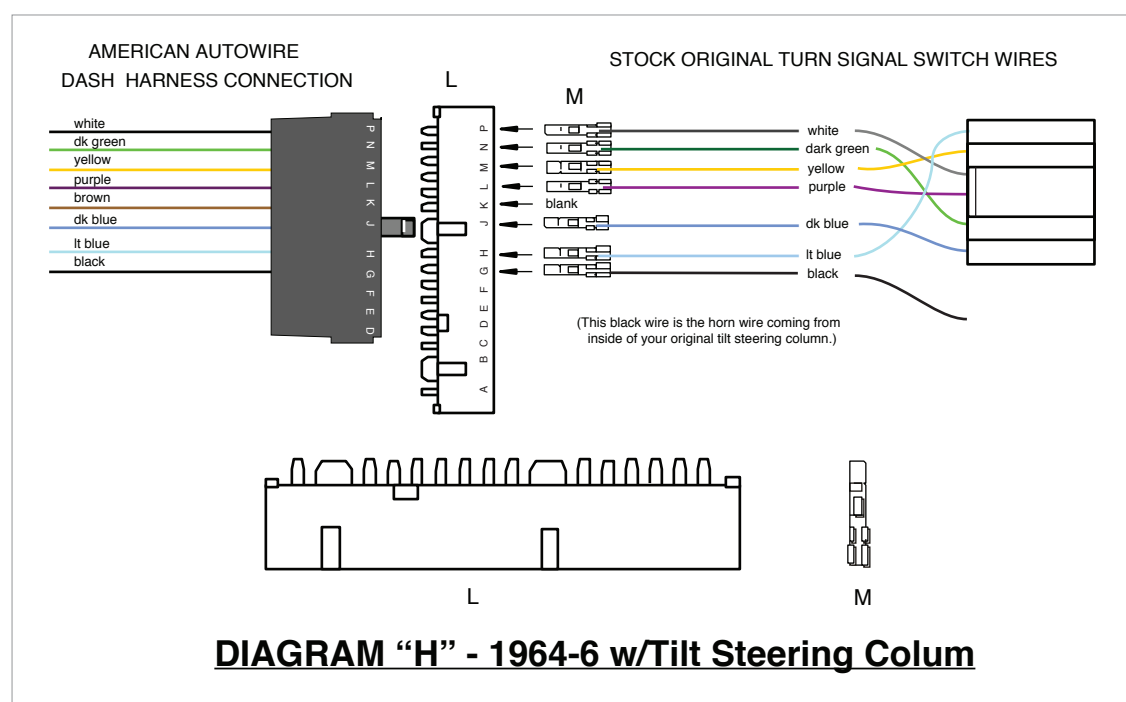
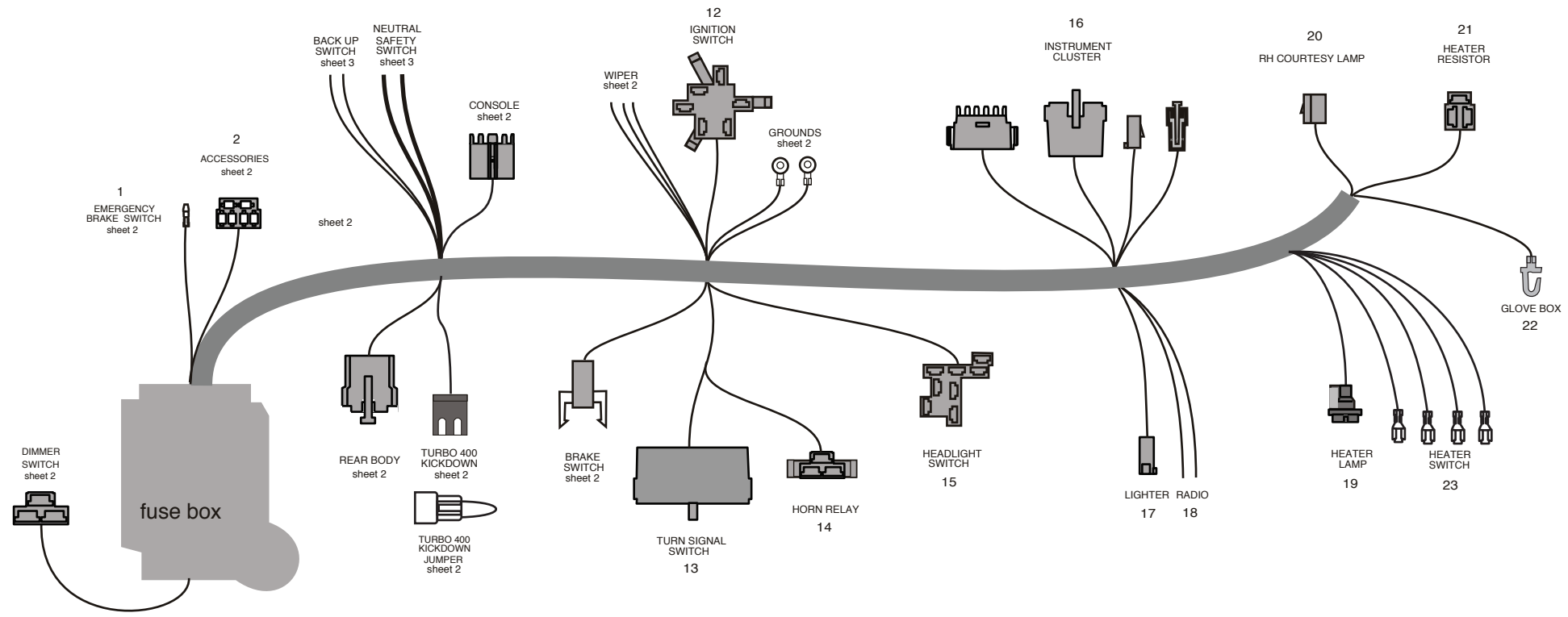

**DIAGRAM "H" - 1964-6 w/Tilt Steering Column**

- |    |                                |   |   |
|----|--------------------------------|---|---|
| 12 | IGNITION SWITCH                | Red<br>Pink<br>Brown<br>Purple  | This connection will plug onto the new ignition switch, 50674.<br>12 volt battery feed<br>12 volt ignition feed<br>12 volt accessory feed<br>12 volt starter feed to Neutral Safety Switch  |
| 13 | TURN SIGNAL SWITCH             | White<br>Dark Green<br>Yellow<br>Purple<br>Brown<br>Dak Blue<br>Light Blue<br>Black | The connector on this harness will mate directly to the 3 7/8" turn signal switch used by GM and many other aftermarket steering column manufacturers. If you are using a stock 1964-66 non tilt or any 1967 column and turn signal switch, remove the existing connector and terminals from your stock steering column and install terminals M and connector L as shown on this sheet, diagram G. If you are using a stock 1964-66 tilt column and turn signal switch, use the stock jumper harness from your original column and crimp on terminals M, then plug into connector L as shown on this sheet, diagram H. If your column uses the 4 1/4" GM plug, simply remove the connector from your column and install connector L maintaining color continuity with the dash harness.<br>12 volt feed from brake switch<br>RH rear stop and turn<br>LH rear stop and turn<br>12 volt ignition feed from turn signal flasher<br>12 volt battery feed from hazard flasher<br>RH front turn<br>LH front turn |
| 14 | HORN RELAY                     | Red<br>Black<br>Dark Green  | Horn relay ground to horn switch<br>Plug the horn relay (found in the fuse, relay, and flasher bag, 500707) into this connector.<br>12 volt battery for relay<br>Relay ground circuit (from steering column)<br>Triggered 12 volts out to horn  |
| 15 | HEADLIGHT SWITCH               | Red<br>Orange<br>Brown<br>Yellow<br>Dark Green<br>White                             | This connection will plug onto the new headlamp switch, 500332.<br>Battery 12 volt input lead to switch for headlamps.<br>Battery fused 12 volt input lead to switch for park / tail output and dash lamp input<br>Park/tail lamp output<br>12 volt output lead to dimmer switch for headlamps<br>Dash lamp output to fuse panel<br>Dome / Courtesy ground  |
| 16 | INSTRUMENT CLUSTER DISCONNECTS | White   | These connectors will plug into the the Intrument Cluster Harness, 510194, bag H. Circuit identifications for this branch are described in those instructions.  |
| 17 | LIGHTER                        | Orange  | 12 volt fused battery feed to lighter   |
| 18 | RADIO                          | Tan<br>Yellow   | 12 volt accessory power feed to radio ("ON" and "OFF")<br>12 volt fused battery feed for clock and memory   |
| 19 | HEATER CONTROL LAMP            | Gray<br>Black   | Dash lamp feed<br>Dash lamp ground  |
| 20 | RH COURTESY LAMP               | Orange<br>White   | Plug this connector into the mating RH courtesy lamp assembly from 500708, bag N.<br>12 volt battery fused feed<br>Courtesy lamp switched ground<br>(Used on stock non A/C equipped cars only) Plug this connector onto the stock heater resistor located on the stock heater box inside the car under the dash.  |
| 21 | HEATER RESISTOR                | Orange  | 12 volt fused battery feed for glovebox lamp  |
| 22 | GLOVEBOX LAMP                  | Brown<br>Yellow<br>Light Blue<br>Orange   | These wires will plug into some connectors contained in the dash loose piece kit. Instructions for plugging them in can be found on page 4, diagrams J and K.<br>12 volt fused switch feed for heat or A/C power. (if using aftermarket A/C, use this wire as the switched "ON" "OFF" feed wire to the aftermarket A/C harness.)<br>To heater resistor<br>To heater resistor<br>To heater resistor and blower motor   |

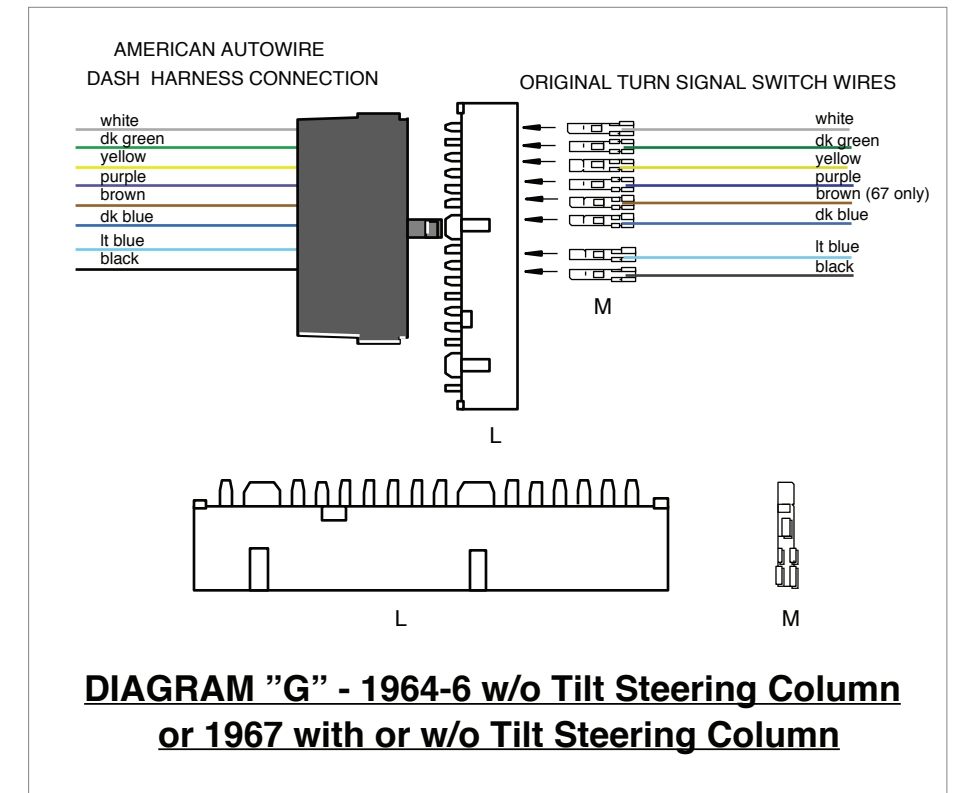

**DIAGRAM "G" - 1964-6 w/o Tilt Steering Column or 1967 with or w/o Tilt Steering Column**



www.americanautowire.com 856-933-0801

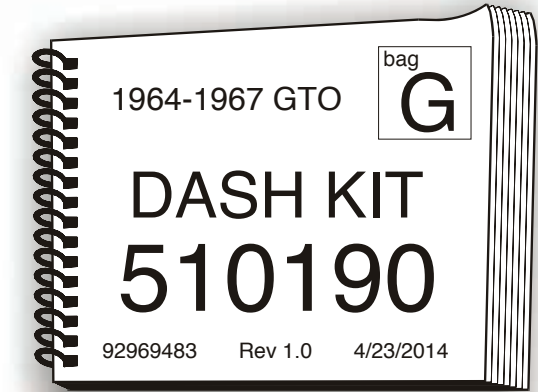

Heater switch connection as viewed looking into the connector.

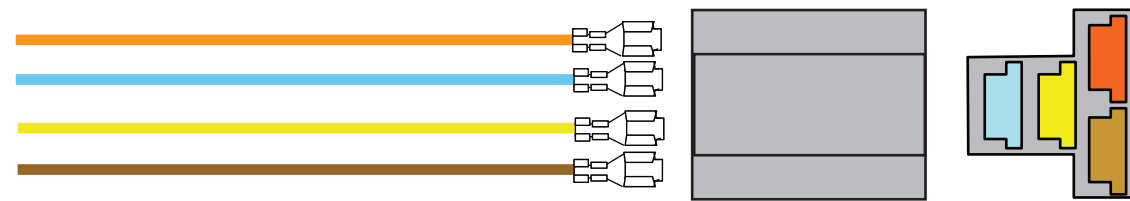

1964 - 1965 GTO, LEMANS, TEMPEST HEATER  
AND BLOWER SWITCH CONNECTION WITH  
FACTORY HEATER AND NO A/C.

**DIAGRAM "J"**

Heater switch connection as viewed looking into the connector.

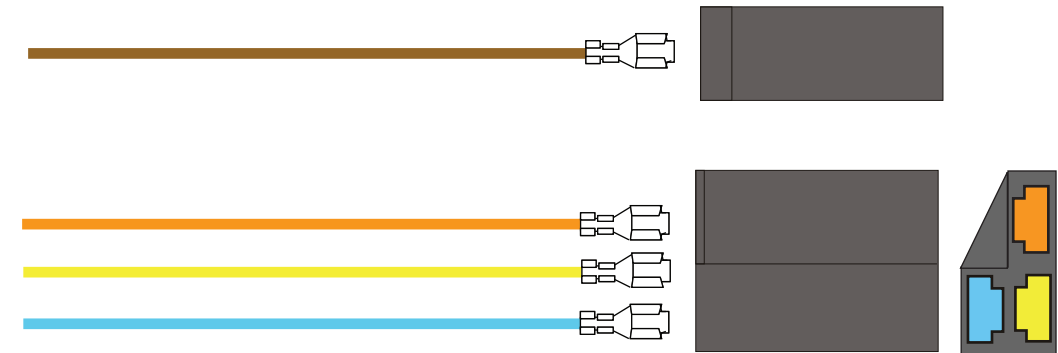

1966 - 1967 GTO, LEMANS, TEMPEST HEATER  
AND BLOWER SWITCH CONNECTIONS WITH  
FACTORY HEATER AND NO A/C.

**DIAGRAM "K"**



www.americanautowire.com 856-933-0801

