

Classic Update Series

67-72 Ford Truck

START HERE !

PLEASE READ THIS BEFORE STARTING INSTALLATION !

This wiring kit is designed for ease of installation. Please read the guidelines below, BEFORE STARTING your installation to guarantee a successful job. Use an appropriate crimping tool which folds the wings of the open barrel terminals down into the wire as shown below. ALL TERMINALS THAT YOU INSTALL SHOULD BE PROPERLY SOLDERED. Our factory crimped terminations are installed by GM approved five ton presses, and soldering these terminations is not necessary. AAW offers a great terminal crimping video entitled "Proper Crimping Video". It can be viewed by visiting YouTube. Type the following address into your web browser to go directly to the video: www.youtube.com/watch?v=8u_EkMsioMy.



PLEASE READ THESE HELPFUL INSTALLATION TIPS BEFORE GOING ANY FURTHER!

Prior to installing the dash/main harness in your vehicle, plug all of the fuses, flashers, (see a detailed photograph on page 13 of this instruction set) and horn relay into the harness. Install the Dimmer, Headlight, Ignition and Wiper switches into their respective connectors on the harness assembly as well. These are all much easier to install onto the harness without the harness being installed in the vehicle. Once the switches and such have all been installed onto the harness, please use care when routing the assembly thru the vehicle as to not damage any of the switches by banging them into any metal supports. See the Fuse Panel Mounting Sheet 92970338, for installation and location of the Fuse Block.

AS THIS HARNESS IS DESIGNED FOR USE IN A MODIFIED TRUCK REQUIRING A HIGHER RATE OF CHARGE, IT DOES NOT SUPPORT THE USE OF A STOCK (ORIGINAL) ALTERNATOR. IT IS DESIGNED FOR USE WITH AN INTERNALLY REGULATED GM "SI" STYLE OR SINGLE WIRE STYLE ALTERNATOR. ADAPTERS (WHICH ARE NOT INCLUDED WITH THIS KIT) THAT ARE AVAILABLE FROM SEVERAL SOURCES WILL BE NECESSARY TO USE ANY ALTERNATOR OTHER THAN A GM "SI" STYLE OR SINGLE WIRE STYLE UNIT.

STEP 1: DISCONNECT YOUR BATTERY:

Disconnect the battery before installing the wiring kit to prevent any accidental shorting caused by loose bare wire ends.

STEP 2: START INSTALLING KIT (see page 3):

This kit is broken down into individual steps that are identified by a letter printed on the instruction sheets visible through each bag. These letters are the order of operation for installing your kit. Start with bag letter G, then H, etc. The order of installation is shown below. Use this main instruction sheet, 92970307, to complete the installation process.

G - 510369 Dash Harness Kit
H - 510370 Gauge Cluster Kit
M - 510371 Rear Body Kit

STEP 3: RECONNECT YOUR BATTERY:

When you have completed the installation and are ready to reconnect the battery, make sure that the following electrical system grounds are in place:

- A. Battery is grounded to the ENGINE BLOCK.
- B. Battery is grounded to the frame.
- C. Engine block is grounded to the frame.
- D. Body is grounded to the frame.

STEP 4: CHECK ALL ELECTRICAL FUNCTIONS:

Any non-functioning items should be checked for proper installation. Any problems with your wiring and electrical circuit functions should be addressed to American Autowire Systems, Inc. as soon as possible to avoid any warranty problems.

If you have any questions concerning this or any of our products, please feel free to call us at 1-856-933-0801.

AMERICAN AUTOWIRE MAKES IT EASY !!

We carry many accessories for your 67-72 Ford Truck

p/n 510585

OEM small terminal crimping tool (18-14 gauge)



p/n 510586

OEM large terminal crimping tool (12-8 gauge)



p/n 500918

Ford Duraspark Ignition Harness



p/n 500802

GM "SI" series to Ford "3G" int. regulated alternator



**American
Autowire**

www.americanautowire.com 856-933-0801

Classic Update Series

1967-72 Ford Truck

510368

© COPYRIGHT 2004 American Autowire / Factory-Fit
Used with express permission of
American Autowire / Factory-Fit

92970307 Rev. 6.0 8/25/2016

Fuse Box Assembly



Please see page 13 of this instruction set for fuse and flasher locations

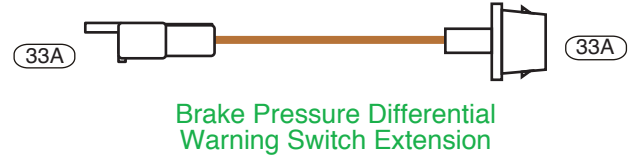
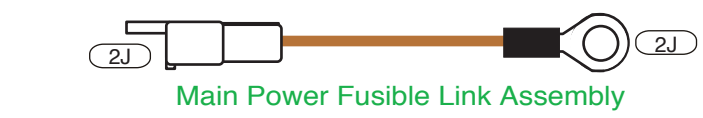
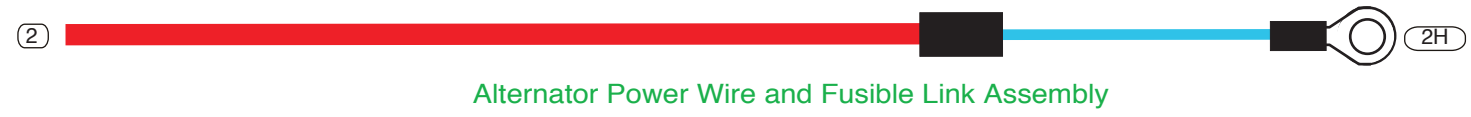
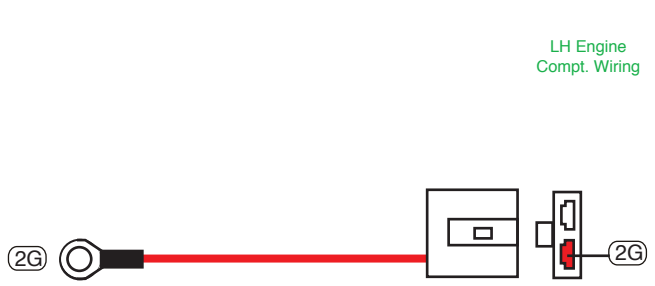
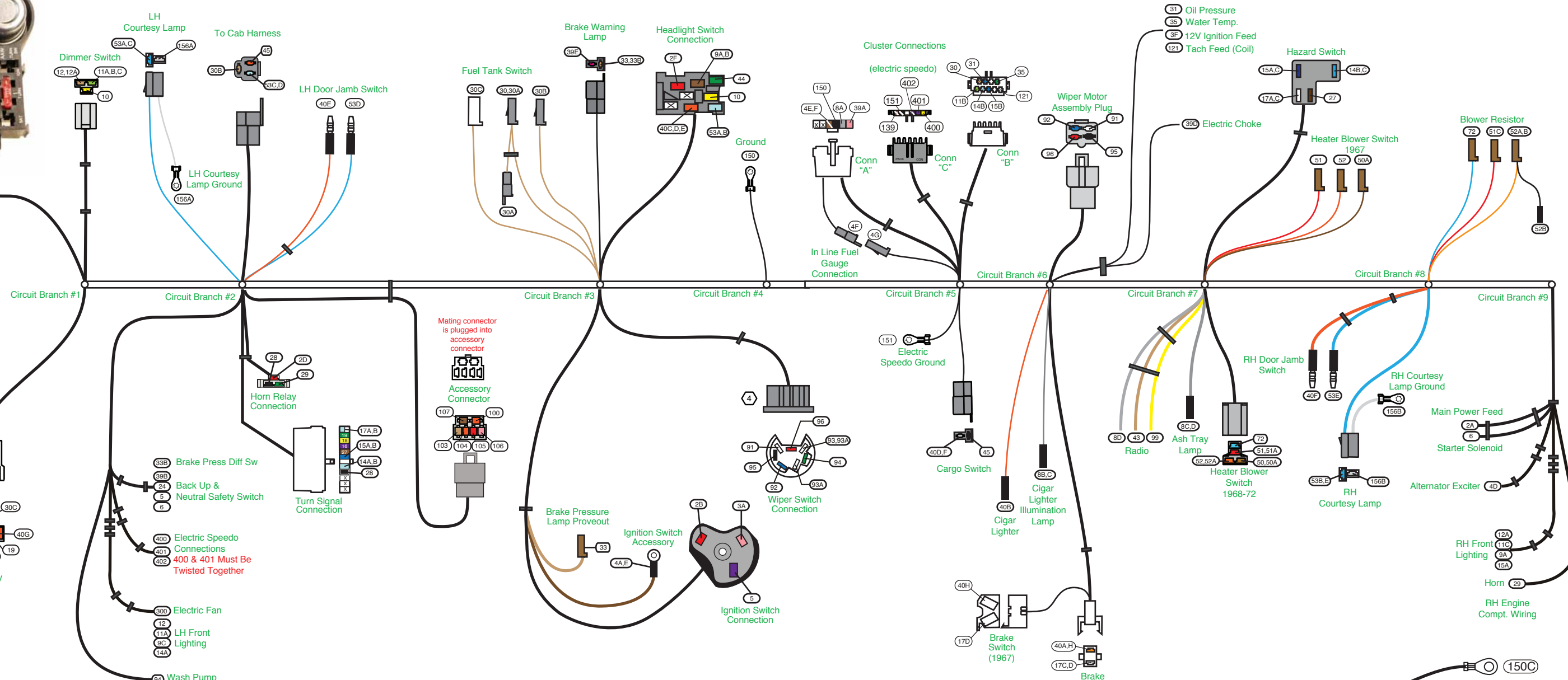

NOTE: Your new underdash courtesy lamp extensions use # 631 bulbs (not included with this kit). They may be purchased at any auto parts store.

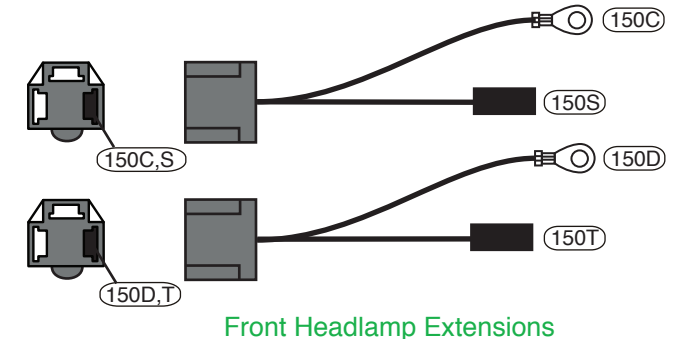
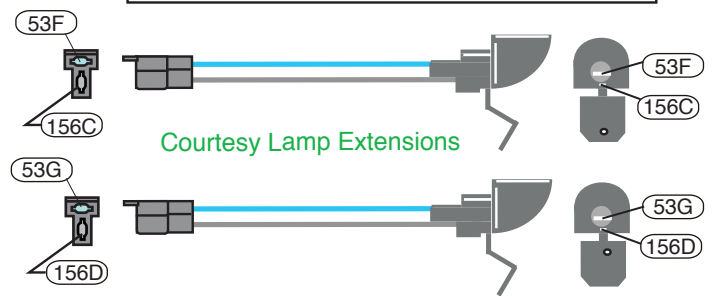

PART # **510368**

DESCRIPTION:

1967-72 Ford Truck Classic Update Series Kit

92970307 Rev. 6.0 8/25/2016

Dash/Main Harness Installation Instructions

The Main Dash Harness 510369 is designed to be mounted in the same location as the original Instrument Panel Harness. Mount the Fuse Block first using the two #10 x 3" screws found in kit 510369. Mount the Fuse Block (see the Fuse Panel Mounting Sheet - 92970388). You will reuse the two original wraparound clips that are attached to the steering column brace to hold the new Dash Harness in place as well as the original clip near the top center of the firewall. Follow these instructions as well as the detailed drawings on pages 11 and 12. After mounting the Fuse Block, install the two 1-1/4" grommets G from kit 510376 into the outboard firewall holes, and the 1" grommet R near the center of the firewall. These are the same wiring pass through holes as used originally.

Circuit Branch 1 - Underdash Connections

Wire # Wire Color Printing

Procedure

Dimmer Switch

Plug this connector onto the Dimmer Switch 500042 and then attach the Dimmer Switch to the floor pan.

10	Yellow	Dimmer SW Feed	Feed from the Headlight Switch.
11A	Light Green	Headlight Hi-Beam	Feed to LH Headlight High Beam.
11B	Light Green	Hi-Beam Indicator Light	Feed to the Hi Beam Indicator Light.
11C	Light Green	Headlight Hi-Beam	Feed to the RH Headlight-High Beam.
12,12A	Tan	Headlight-Low Beam	Feed to LH and RH Headlights-Low Beam.

Rear Body Connection

This connector will plug into the Rear Body Kit, 510371. Specific connections are addressed in that kit. The Rear Body Harness will pass out to the engine compartment through the LH driver's side firewall grommet G (included in kit 510376) shown on page 12, Figure C.

9B	Brown	Rear Running Lights	Feed for the Rear Park, Side Marker and License Lamps.
9C	Brown	Park Lights	Feed for the Front Park Lights.
17B	Lt. Blue	Third Brake Light	Feed for an aftermarket Third Brake Light.
18	Yellow	Left Rear Turn	Feed to the Left Rear Stop and Turn Lamp.
19	Dk. Green	Right Rear Turn	Feed to the Right Rear Stop and turn Lamp.
24	Lt. Green	Back Up Lt Sw	Feed to the Back-up Lamp Switch.
30C	White	Gas Gauge AUX Tank	Auxiliary Fuel Tank Sender.
40G	Orange	12v Battery Fused	12v battery feed for aftermarket LED Rear Lights.

Circuit Branch 2 - Under Hood Connections LH Engine Compartment (Drivers Side)

The Brake Pressure Differential Warning Switch NOTE: We have provided you with the connection to a late model Brake Pressure Differential Warning Switch in the form of a single wire pigtail assembly (Brake Pressure Differential Warning Switch Extension Harness shown on page 2, circuit 33A). The old original stock Ford twin post switch is no longer available and has been replaced with the newer single post style switch. AAW recommends that you replace the older brake warning switch with the new replacement style switch. However, if you have a functioning twin post switch and wish to use it, simply cut the wires about 6 inches back from your old switch connector, double them together, and splice them into the Brake Pressure Differential Warning Switch Extension Harness. Now plug this pigtail assembly onto the switch (see Figure C on page 12).

Wire # Wire Color Printing

Procedure

33A	Tan	no printing	Brake warning feed in the Brake Pressure Differential Warning Switch Extension.
-----	-----	-------------	---

Brake Switch Connection Route wire (33B) to the Brake Pressure Differential Warning Switch Extension Harness, cut to length, install terminal "B", and plug into connector "E" as shown on page 12 (both are found in kit 510376). Connect to the Brake Pressure Differential Warning Switch Extension Harness.

33B	Tan	Brake Switch	Brake warning feed.
-----	-----	--------------	---------------------

The Back-up and Neutral Safety Switches Route the circuits to the Back-up Lamp Switch and to the Neutral Safety Switch and connect. For 4-speed M/T applications, the Back-up Switch is located at the top rear of the transmission. for 3-speed M/T applications, the Back-up Switch is located on the steering column in the engine compartment. For Automatic Transmission applications, the Neutral Safety/Back-up Switch is located near the Steering Column or on the transmission depending on transmission. **If you have a manual transmission, connect the 5 and 6 wires together to complete the starter circuit or your vehicle will not crank.** A typical aftermarket connection for the Neutral Safety/Back-up Switch can be found on page 12, Figure E.

5	Purple	Neutral Safety Switch	Start feed from the Ignition Switch to the Neutral Safety Switch.
6	Purple	Starter Solenoid	Start circuit from the Neutral Safety Switch to the Starter Solenoid.
24	Light Green	Back UP LT SW	Feed from the Back-up Lamp Switch to the Back-up Lamps.
39B	Pink	12V Ignition	12V feed to the Back-up Lamp Switch.

Continued on page 4

Fuse Box Assembly

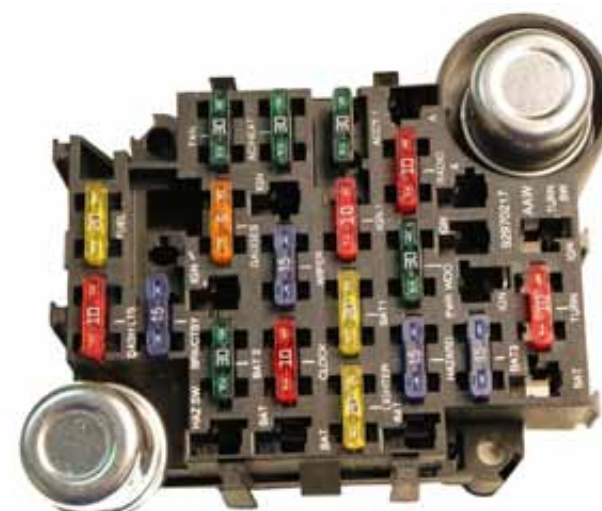

Please see page 13 of this instruction set for fuse and flasher locations

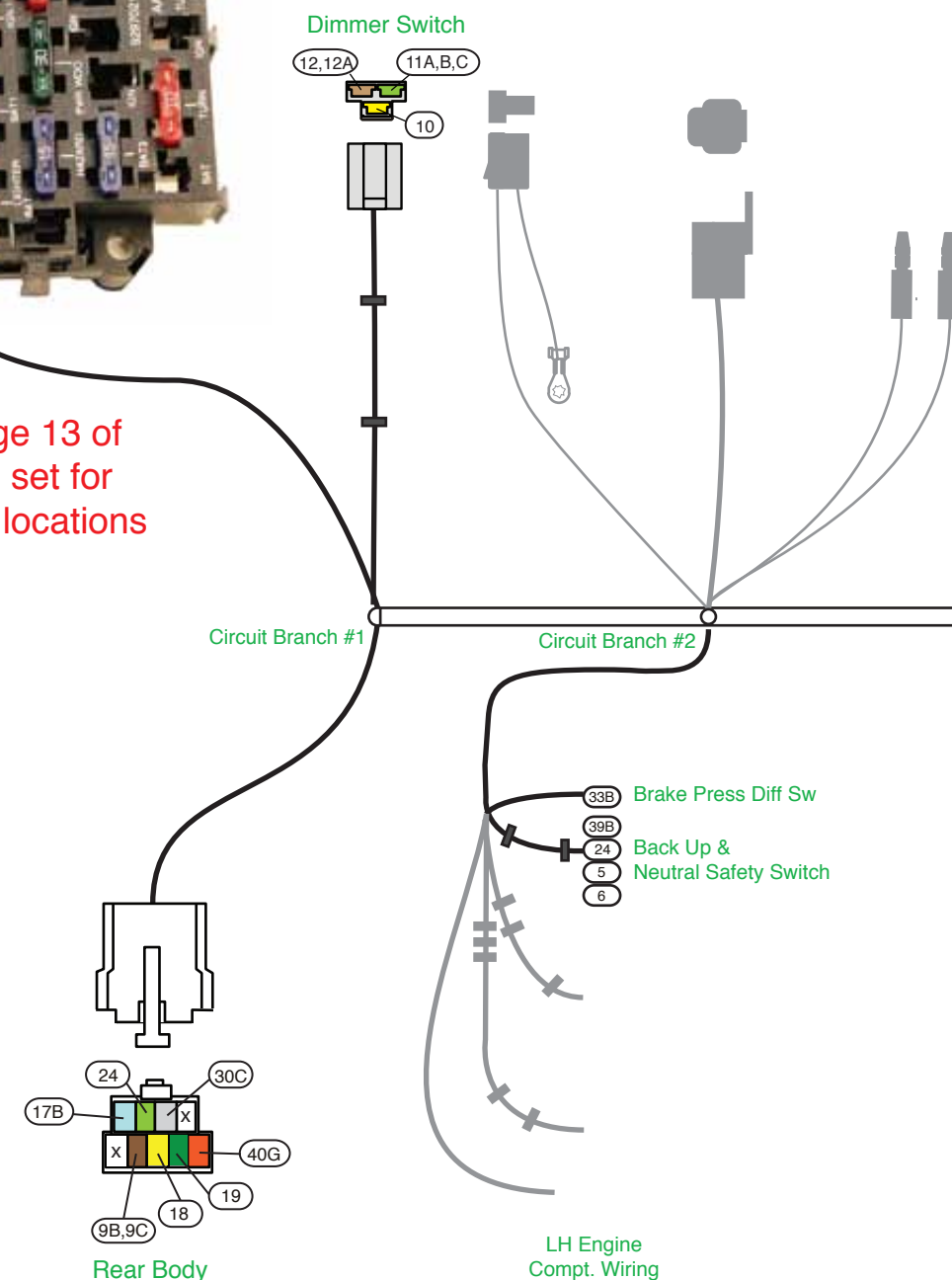

www.americanautowire.com 856-933-0801

PART # **510368**
 DESCRIPTION:
**1967-72 Ford Truck
 Classic Update Series Kit**

92970307 Rev. 6.0 8/25/2016

Dash/Main Harness Installation Instructions

Circuit Branch 2 - Under Hood Connections LH Engine Compartment (Drivers Side)

Aftermarket Electric Speedometer (see Figure H) Note that wires 400 and 401 must remain twisted together.

Wire #	Wire Color	Printing	Procedure
400	Yellow	VSS Ground	Vehicle Speed Sensor Ground.
401	Purple	VSS Signal	Vehicle Speed Sensor Signal.
402	Purple/White	VSS Power	Vehicle Speed Sensor Power if using a 3 wire sender.

Electric Fan

300 Orange Electric Fan Feed to the trigger wire of the Electric Fan Relay (relay not supplied with kit).

Windshield Washer Pump The Windshield Washer Reservoir (with the Washer Pump) is located on the left side of the engine compartment unless your vehicle has the Power Pak option, then the reservoir is located on the right side of the Engine Compartment. Enough wire length has been provided to reach either Windshield Washer Reservoir location.

94 Dark Green no printing Feed to the washer pump. You will need to add a ground wire.

Headlights Install Grommet Z in the LH Radiator Core Support. Select the light green Headlight High Beam wire (11A) and the tan Low Beam wire (12). Route these wires to the LH Headlight and cut to length. Crimp on terminal "A", found in kit 510376, to each wire, and insert the wires into the Front Headlamp Extension Harness (found in bag G), also see figure C on page 12.

11A	Light Green	Headlight-Hi Beam	High Beam feed to the LH headlight.
12	Tan	Headlight-Low Beam	Low Beam feed to the LH headlight.

Front Headlamp Extension Harness This can be found in bag G and is shown on page 2 and in figure "C" on page 12. The 150C ground wire ring terminal will attach to the original Headlamp ground wire location. The 150S female bullet ground wire will attach to the Park Lamp Assembly ground lead.

150C	Black	Ground	Ground for the Left Headlight.
150S	Black	Ground	Ground for the Park Lamp Assembly.

Left Hand Park/Turn Lamp & Socket Assembly **NOTE:** You will need to reuse the original Park/Turn Signal Lamp & Socket Assembly but will have to replace the 2-way bullet connector with a 2-way AAW connector (see figure C on page 12). Remove the old connector and install terminals W to the two wires and install the wires in the 2-way connector "V" (all supplied in kit 510376) as shown in figure C on Page 12. **The original Ford Left Front Turn wire is green/white (67-71) or white/blue (72) and the Park Light wire is black/yellow (67-69) or brown (70-72).**

Left Hand Park/Turn Lamp Connector Select the brown Park Light wire (9C) and the light blue Left Front Turn wire (14A). Route these wires to the LH Park/Turn Lamp and cut to length. Install terminal B, found in kit 510376, to each wire, and insert the wires into connector T. Be sure to align the AAW brown Park Light wire with the Ford Park Light wire (black/yellow or brown) and the AAW light blue Left Front Turn wire with the Ford Left Front Turn wire (green/white or white/blue).

9C	Brown	Park Lights	Park Light feed.
14A	Lt Blue	Left Front Turn	Turn Signal feed.

Circuit Branch 2 - Under Dash Connections

Left Hand Door Jamb Switch Connection Route the two bullet terminals through the Door Jamb switch hole from behind, and connect to the Door Jamb Switch Y (located in kit 510376). Polarity does not matter. Attach the Door Jamb Switch to the mounting bracket.

Wire #	Wire Color	Printing	Procedure
40E	Orange	12V Battery-Fused	12 Volt Fused Battery feed.
53D	Lt Blue	12V CTSY SW	Feed to the Courtesy and Dome Lights

Cab Harness Connection Connect this connector to the Cab Harness.

30B	Tan	Gas Gauge	Feed to the Primary Fuel Tank Sender.
45	BLK/Red	no printing	Feed to the Cargo Lamp.
53C, 53D	Lt Blue	12V CTSY SW	Feed to the Dome Lamp.

Cab Harness NOTE: This harness is shown on page 2 and is found in Bag G. This Harness includes the wiring for the Primary Fuel Tank (30M), and will include the wiring for the Dome Lamp (53M), and the Cargo Lamp (45M) if so equipped. For ease of assembly, route all three wires up the "A" Pillar at the same time.

FIGURE "H"

Typical 3 wire Autometer 5291 VSS connection

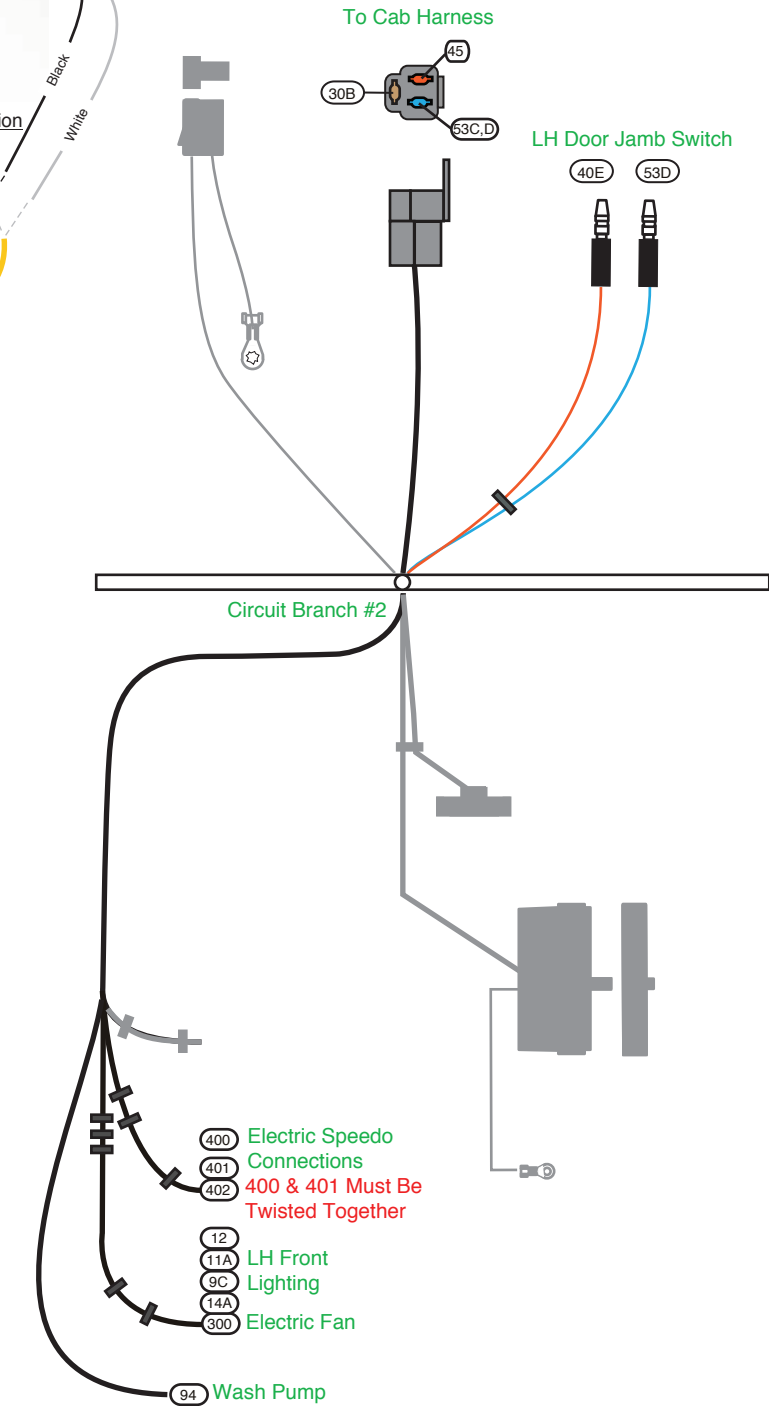
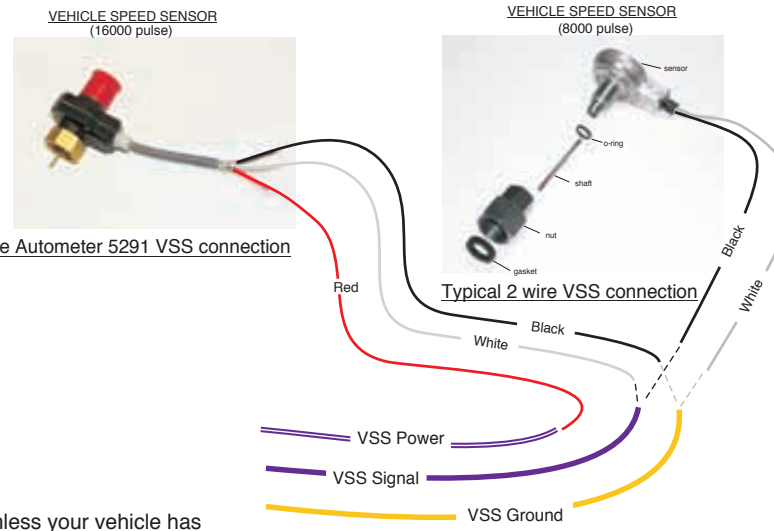

www.americanautowire.com 856-933-0801

PART # **510368**
 DESCRIPTION:
**1967-72 Ford Truck
 Classic Update Series Kit**

92970307 Rev. 6.0 8/25/2016

Dash/Main Harness Installation Instructions

Procedure

Circuit Branch 2 - Underdash Connections

Fuel Tank Wiring If you have an In-Cab Fuel Tank, 30M will be routed up the "A" Pillar and back to the Fuel Tank. Cut to length, slide on sleeve J, install ring terminal M, and position the sleeve over the crimped wires. Attach the ring terminal M to the Fuel Tank Sender. Attach the ring terminal of Ground Wire 150M to ground at the original ground location and route the other end of 150M to the Fuel Tank sender. Install terminal F and plug into connector H. Attach to the fuel Tank sender ground. If you don't have an In-Cab Fuel Tank, route 30M out through the firewall grommet G and back to the Fuel Tank alongside the Rear Body Wiring. Cut to length, crimp on terminal B, and add Connector E, then connect to the Fuel Tank Extension Harness (from Bag M - 510371 Rear Body Kit).

Wire # Wire Color Printing Procedure

30M Tan Gas Gauge Feed to the Primary Fuel Tank.

150M Black Ground Primary Fuel Tank Sender Ground.

Dome Lamp Wiring If you have a Dome-Lamp, obtain circuit 53M from kit Bag G and plug into the 3-way Cab Harness (see page 2). Be sure to match the wire colors with the Dash Harness connector. Route the other end of 53M up the "A" Pillar and over to the Dome Lamp. Cut to length, slide on sleeve D, install terminal X, and position the sleeve over the crimped wires. Connect terminal X to the Dome Lamp pigtail.

53M Light Blue 12V CTSY SW Feed to the Dome Lamp.

Cargo Lamp Wiring If you have a Cargo Lamp, obtain circuit 45M from Bag G and plug into the 3-way Cab Harness (see page 2). Be sure to match the wire colors with the Dash Harness connector. Route the other end of 45M up the "A" Pillar and over to the Cargo Lamp. Cut to length, slide on sleeve D, install terminal X, and position the sleeve over the crimped wires. Connect terminal X to the 2-way molded connector at the Cargo Lamp pigtail. Attach the ring terminal of Ground wire 150N to a good ground location and route the other end of 150N to the Cargo Lamp. Cut to length, slide on sleeve J, install terminal U, and position the sleeve over the crimped wires. Connect terminal U to the 2-way molded connector at the Cargo Lamp pigtail. The Ford feed wire to the cargo lamp is black/red and the ground is black.

45M Black/Red no printing Feed to the Cargo Lamp.

150N Black Ground Cargo Lamp Ground.

Left Hand Courtesy Lamp Connector Plug in one Under Dash Courtesy Lamp Extension in bag G (as shown on page 2) to complete this circuit and attach to the lower Instrument Panel.

53A, 53C Light Blue 12V CTSY SW Feed to the Left Hand Courtesy Lamp.

156A White CTSY Ground LH Courtesy Lamp ground. Attach this ring terminal to a good chassis ground.

Accessory Connector Use the provided 6-way empty connector, which is attached to the 6-way connector on the Dash Harness, and terminals B or C (see kit 510376) to add power leads (not provided) for the following systems:

Wire#	Wire Color	Printing	Fuse block	Rating	Description
100	Orange	no printing	BAT3	20A	Battery feed for Audio systems.
103	Tan	Fuel Pump	not marked	20A	Ignition feed for electric fuel pump or fuel flow valve.
104	Orange	Power Seats	BAT2	30A	Battery feed for Power Seats.
105	Red	Power Locks	BAT1	20A	Battery feed for Power Locks.
106	Pink	Power windows	PWR WDO	30A	Ignition feed for Power Windows.
107	Brown	no printing	ACCY1	30A	Accessory feed for Cruise Control or options.

Horn Relay Connector Plug the Horn relay (found in the 510353 Fuse kit) into this connector.

2D Red 12V Battery 12V Battery feed to the Horn Relay.

28 Black Horn Relay Ground Relay ground circuit (to Steering Column).

29 Dark Green Horn Feed to the Horn.

Turn Signal Switch Connector Plug into the Steering Column Turn Signal Switch Connector. If you are using a stock Ford Steering Column on your vehicle, refer to Diagram 'A' and "Table A" - AAW Turn Signal Switch wires to stock turn signal switch on page 10 for proper mating directions. This Dash Harness is designed to function with a GM style turn signal switch. Our connector mates to a 3 7/8 inch long plug used on 1969-74 GM, IDIDIT, and many other aftermarket steering columns. Starting from 1975 on up, the GM switch changed and began using a 4-1/4 inch connector. That connector is from the same family and uses the same terminals. By using the supplied mating connector (L) and terminals (M) located in the loose piece kit bag G, it is easy to adapt any steering column to this Dash Harness. The different functions of the wires are as follows:

14A, 14B	Light Blue	Left Front Turn	Feed to LH Front Turn Signal Lamp and cluster Indicator Lamp.
15A, 15B	Dark Blue	Right Front Turn	Feed to RH Front Turn Signal Lamp and Cluster Indicator Lamp.
16	Purple	Turn Switch Feed	Turn Signal feed into Steering Column from the turn Signal Flasher.
17A	Light Blue	Third Brake Light	12V feed to Third Brake Light.
17B	White	Brake SW	12V input from Brake Switch to Turn Switch for Rear Brake Lights.
18	Yellow	Left Rear Turn	Feed to LH Rear Turn Signal Lamp.
19	Dark Green	Right Rear Turn	Feed to RH Rear Turn Signal Lamp.
28	Black	Horn Relay Ground	Steering Column Horn ground from Horn Relay.

NOTE: The courtesy lamp extension from page 2, that plugs onto the connector at branch 2 on this page, uses a # 631 bulb (not included with this kit). They may be purchased at any auto parts store.

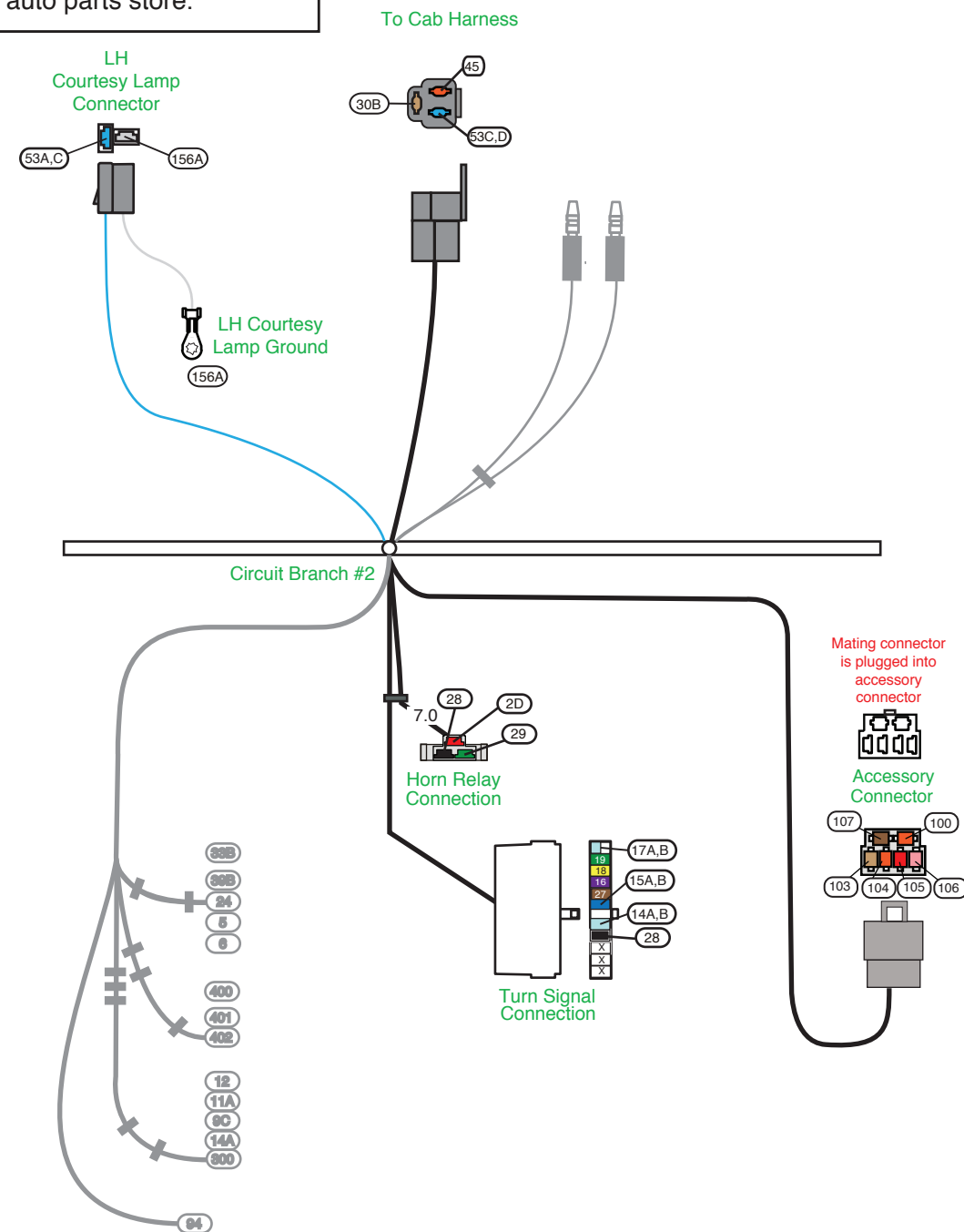

www.americanautowire.com 856-933-0801

PART # **510368**
 DESCRIPTION:
**1967-72 Ford Truck
 Classic Update Series Kit**

92970307 Rev. 6.0 8/25/2016

Dash/Main Harness Installation Instructions

Circuit Branch 3 - Under Dash Connections

Headlight Switch Connector Plug this connector to Headlight Switch 510321.

Wire #	Wire Color	Printing	Procedure
2F	Red	12V Battery	Un-fused 12V Battery feed from the Fuse Block.
9A	Brown	Park Lights	Feed to Front Park Lights.
9B	Brown	Rear Running Lights	Feed to Rear Tail Lights, Rear Side Marker Lights and License Lamps.
10	Yellow	Dimmer SW Feed	Feed to Dimmer Switch for Headlights.
40C	Orange	12V Battery-Fused	Fused 12V battery feed from the Fuse Block.
40D	Orange	12V Battery-Fused	Feed to the Cargo Lamp Switch.
40E	Orange	12V Battery-Fused	Feed to LH Door Jamb Switch.
44	Dark Green	no printing	Feed to Fuse Block for Dash Lights.
53A,53B	Light Blue	12V CTSY SW	12V Switched feed to Courtesy Lights and Dome Lamp.

Brake Warning Lamp The original Dash mounted Brake Warning Lamp uses a unique socket assembly that must be re-used. You will need to cut the purple (for 1967 it is green) and red with yellow stripe (for 1967 it is yellow) wires about 5 inches from the back of the original socket and install terminal B to each wire. Plug these wires into connector T so that the original red with a yellow stripe (or yellow) wire mates with the AAW pink "12V ignition" wire, and the original purple (or green) wire mates with the AAW tan "Brake Light/Switch" wire.

33,33B	Tan	Brake Light/Switch	Ground for the Brake Warning Lamp.
39E	Pink	12V Ignition	12V Ignition feed for the Brake Warning Lamp.

Fuel Tank Switch Connectors If your truck has dual fuel tanks, plug the three 1-way Fuel Tank Switch connectors onto your Fuel Tank Selector Switch, as shown in Figure F, then install the switch into the Dash. If your truck only has a single tank, plug the tan 30B wire with the black connector, into the mating black connector on the tan 30A wire. No other connections are necessary.

30	Tan	Gas gauge	Gas gauge feed to the Cluster connector.
30A	Tan	Gas Gauge	Fuel Tank Selector Switch pigtail.
30B	Tan	Gas Gauge	Feed to the Primary Fuel Tank Sender.
30C	White	Gas Gauge Aux Tank	Feed to the Auxiliary Fuel Tank Sender.

Wiper Switch Connector Plug this connector onto the Wiper Switch 510322.

91	White	no printing	Switched 12V lead out for wiper low speed.
92	Dark Blue	no printing	Switched 12V lead out for wiper high speed.
93,93A	White	Wiper Feed	12V fused feed for Wiper Switch Assembly.
93A	White	Wiper Feed	12V fused feed for Washer Pump.
94	Dark Green	no printing	Switched 12V lead out for Washer Pump.
95	Black	no printing	Wiper Motor park.
96	Red	no printing	Wiper Motor low park.

Ignition Switch Connector Plug this connector to the Ignition Switch 510053.

2B	Red	12V Battery	12V un-fused battery feed from the Fuse Block.
3A	Pink	Ignition Feed	Ignition feed to the Fuse block.
5	Purple	Neutral Safety Switch	Start feed to the Neutral Safety Switch.

Ignition Switch Accessory Eyelet Attach this eyelet to the Ignition Switch after the Ignition Switch Connector is plugged in. Use the nut to securely fasten the eyelet to the Ignition Switch threaded stud.

4A	Brown	Ignition SW ACCY	Accessory feed to the Fuse Block.
4E	Brown/White	no printing	Accessory feed (resistance wire) to the Cluster.

Ignition Switch 1-way Connector Connect this to the Ignition Switch after the Ignition Switch Accessory Eyelet is attached. this connector plugs onto the blade terminal which is located on the side of the Ignition Switch. This wire provides the bulb check ground for the Brake Warning Lamp circuit when the Ignition Switch is in the "Start" position.

33	Tan	Brake Light/switch	Brake Warning Lamp bulb check during crank.
----	-----	--------------------	---

Circuit Branch 4 - Under dash Connection

Ground Lead Attach this wire to a good chassis ground. NOTE: DO NOT attach this eyelet with the 151 ground wire in Circuit Branch #5.

150	Black	Ground	Cluster ground
-----	-------	--------	----------------



Figure "F"
Dual fuel tank
switch
connection

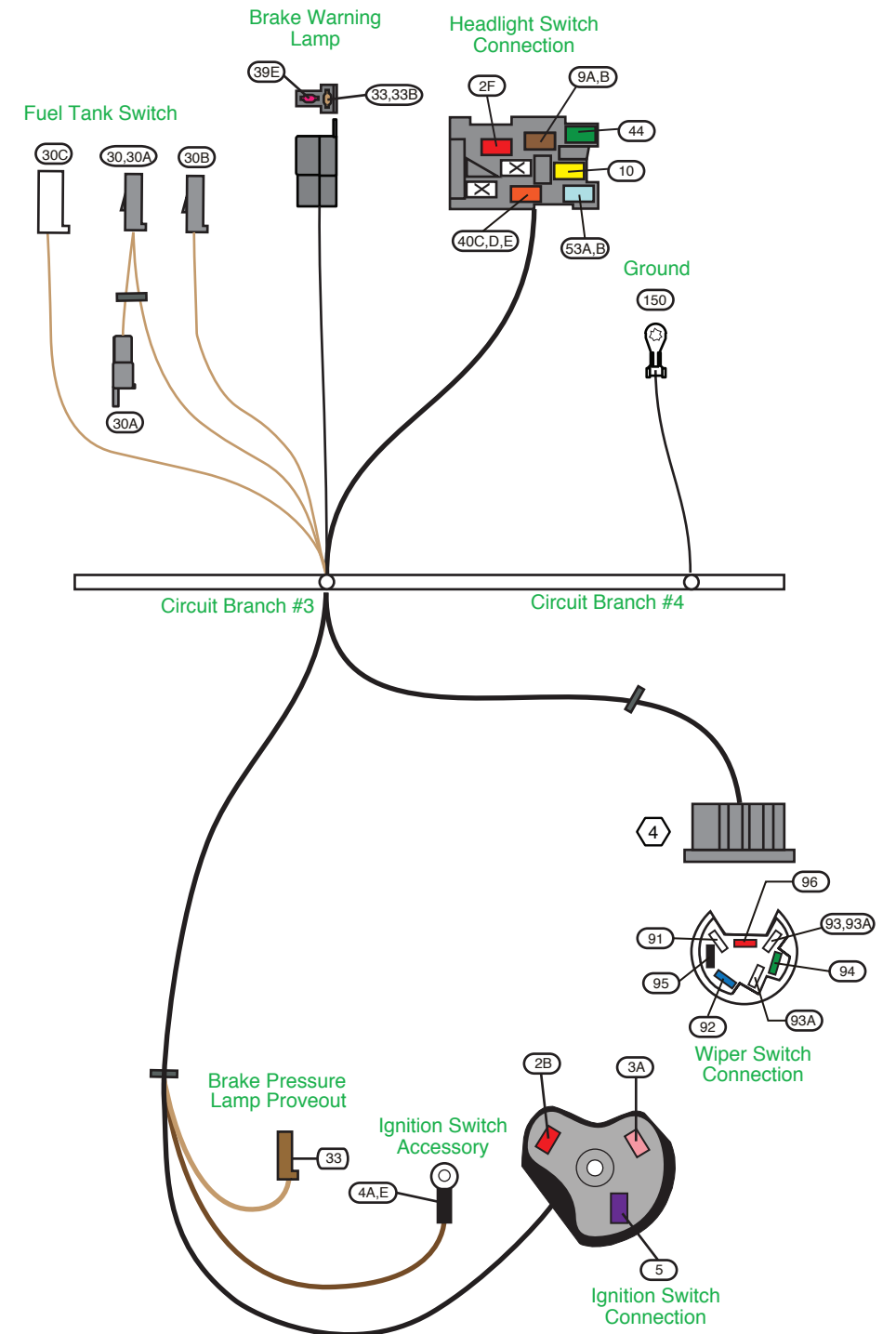

www.americanautowire.com 856-933-0801

PART # **510368**
DESCRIPTION:
**1967-72 Ford Truck
Classic Update Series Kit**

92970307 Rev. 6.0 8/25/2016

Dash/Main Harness Installation Instructions

Circuit Branch 5 - Under Dash Connections

Aftermarket Electric speedometer Ground Attach this wire to a good chassis ground. NOTE: DO NOT attach this eyelet with the "150" ground eyelet in Circuit Branch #4.

Wire#	Wire Color	Printing	Procedure
151	Black/White	Speedo Ground	Ground for an Aftermarket Electric Speedometer.

Instrument Cluster Connections These connections will plug into the cluster connection Kit 510370 (see Bag H). Instructions are included in that kit.

Cluster Connector "A"

4E	Brown/White	no printing	Cluster feed (resistance wire - 8.5 ohms) for 1970-1972 vehicles.
4F	Brown	no printing	Cluster 12V feed for 1967-1969 vehicles.
8A	Gray	Dash Lights	Fused 12V from the Fuse Block for the Cluster Illumination Lights.
39A	Pink	12V Ignition	fused 12V for Oil Pressure Lamp or Aftermarket Gauges.
150	Black	Ground	Cluster ground.

Cluster Connector "A" Inline 12V Feed Connection NOTE: Connect the 1-way male and female black connectors for the 1967-1969 vehicles. Do no connect if you have a 1970-1972 truck.

4F	Brown	no printing	Cluster 12V feed for 1967-1969 vehicles.
4G	Brown	no printing	Cluster 12V feed for 1967-1969 vehicles.

Cluster Connector "B"

11B	Light Green	Hi Beam Indicator Light	Feed to High Beam Indicator Light.
14C	Light Blue	Left Dash IND	Feed to Left Turn Signal Indicator Light.
15B	Dark Blue	Right Dash IND	Feed to Right Turn Signal Indicator Light.
30	Tan	Gas Gauge	Fuel Sender signal from the Fuel Tank Sending Unit.
31	Dark Blue	Oil Pressure Sender	Oil Pressure Sender signal from engine.
35	Dark Green	Water Temp Sender	Water Temperature Sender signal from engine.
121	White	Coil->TACH	Feed for an Aftermarket Tachometer.

Cluster Connector "C" This connector contains the circuits for an Aftermarket Electric Speedometer. Wires "400" and "401" must remain twisted together.

139	Pink/White	Speedo Power	Fused 12V feed for the Electric Speedometer
151	Black/White	Speedo/Ground	Electric Speedometer ground.
400	Yellow	VSS Ground	Vehicle Speed Sensor ground.
401	Purple	VSS Signal	Vehicle Speed Sensor signal.
402	Purple/White	VSS Power	Vehicle Speed Sensor power.

Cargo Lamp Switch Connect to the Cargo Lamp Switch. You will need to replace the connector on the Cargo Lamp with connector T. Cut the original connector from the switch near the connector and install terminals B to each wire . Plug the wires into connector T. The original green with yellow stripe wire will mate with the AAW orange wire, and the original black with red stripe wire will mate with the AAW black with a red stripe wire.

40D,40F	Orange	12V Battery-Fused	Feed to Cargo Lamp Switch.
45	Black/Red	no printing	Feed to the cargo Lamp.

Circuit Branch 6 - Under Hood Engine Wiring Included are circuits for the coil, the water and oil pressure sensors, and an aftermarket electric choke.

Ignition Feed This is your 12V switched power source for the distributor / coil. This can be connected directly to the "Bat" terminal on a typical HEI Distributor, to a Ballast Resistor as in a point's type Distributor, or to be used as the ignition power source for an Aftermarket Ignition Module such as an MSD or "Dura Spark" module. see the installation instructions for the type of Distributor you are using for specific connection requirements. If you are using a GM style HEI distributor, terminal C and connector P have been provided to make that connection (see page 11 figure A for some examples).

Wire#	Wire Color	Printing	Procedure
3F	Pink	Ignition Feed	Feed for the ignition.

Engine Sensors and Electric Choke Route the 31 and 35 wires to the Oil Pressure and Water temperature Sending Units, cut to length, install terminals B or M (install sleeve J first if using M, plug into connector N (if using terminal B), see page 11 figure A. See parts kit 510376 for connectors and terminals. route the 39D wire to the Electric choke (if equipped), no mating connectors or terminals have been provided. Tape back if not used.

31	Dark Blue	Oil Pressure Sender	Oil Pressure Sending Unit.
35	Dark green	Water Temp Sender	Water Temperature Sending Unit.
39D	Tan	Electric Choke	On carbureted trucks, connect to the electric choke.

Tachometer This can be connected directly to the tachometer terminal on a typical HEI distributor, to the negative side of the coil, or a tachometer connection in an aftermarket ignition module such as an MSD module. If you are using a GM style HEI distributor, terminal B and connector Q have been provided to make that connection (see page 11, figure A).

121	White	Coil ->TACH	Tachometer feed wire.
-----	-------	-------------	-----------------------

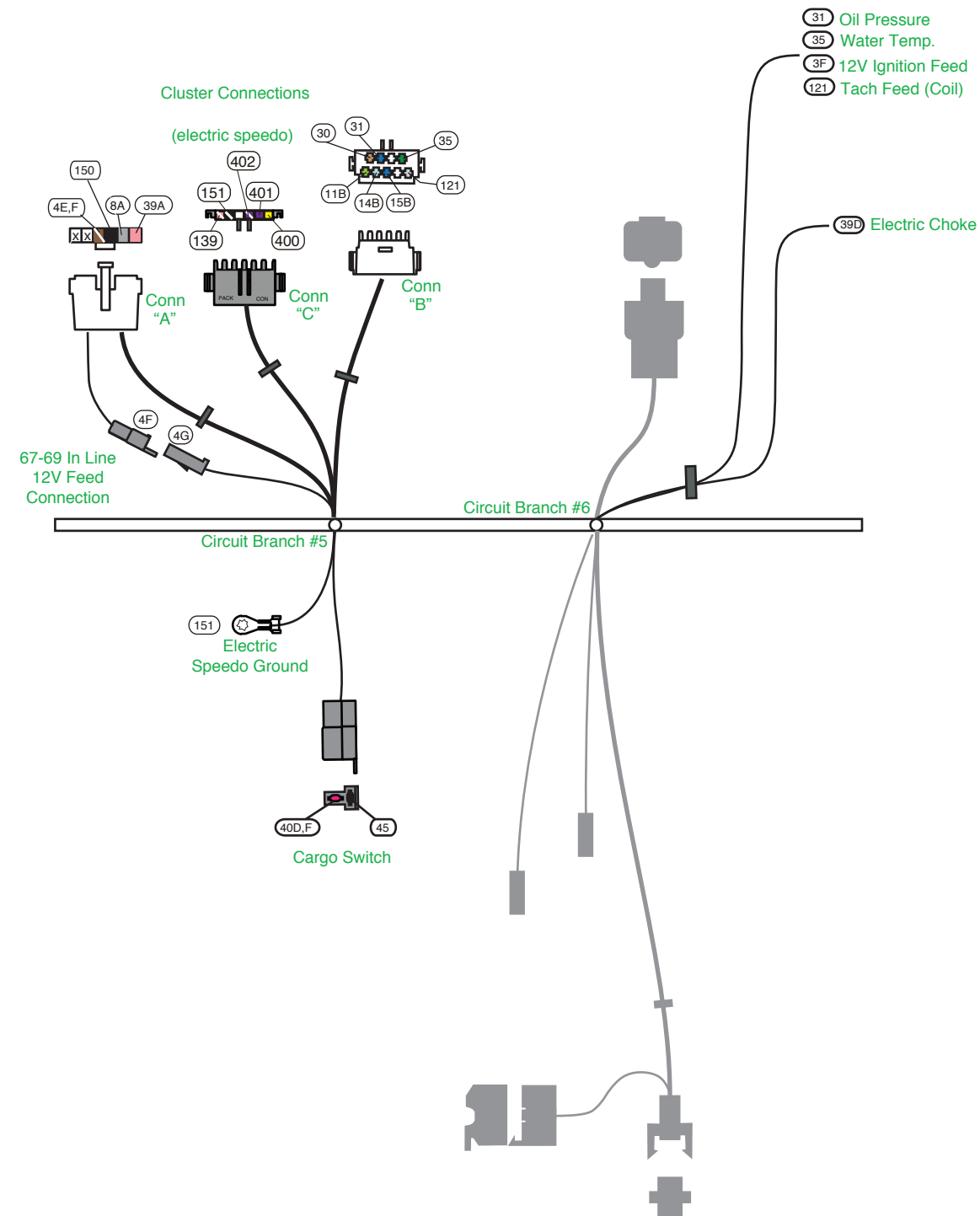

www.americanautowire.com 856-933-0801

PART # **510368**
 DESCRIPTION:
**1967-72 Ford Truck
 Classic Update Series Kit**

92970307 Rev. 6.0 8/25/2016

Circuit Branch 6 - Under Dash Connections

Wiper Motor Assembly The wiring connector on the factory Wiper Motor Pigtail will have to be replaced with an AAW 4-way black connector S (found in kit 510376) that mates with the 4-way white Wiper Motor connector on the AAW Dash Harness. Cut the four wires (red, white, blue and black) on the Wiper Motor pigtail near the original connector. Install terminal B (found in kit 510376) to each wire. Plug these wires into connector S. Be sure to maintain color continuity between the original Ford Wiper Motor wires and the AAW Dash Harness wires (red to red, white to white, blue to blue and black to black) Now plug the white Wiper Motor connector on the Dash Harness to the new black AAW connector S on the Wiper Motor pigtail.

Wiper Motor Connector Plug to the Wiper Motor pigtail.

Wire#	Wire Color	Printing	Procedure
91	White	no printing	Switched 12V feed for Wiper low speed
92	Dark Blue	no printing	Switched 12V feed for Wiper high speed.
95	Black	no printing	Wiper Motor park.
96	Red	no printing	Wiper Motor low park.

Cigar Lighter Illumination Lamp Plug this connector to the Cigar Lighter Illumination Lamp Assembly.

8B,8C Gray Dash Lights Feed for the Cigar Lighter Illumination.

Cigar Lighter Connector Plug this connector to the Cigar Lighter.

40B Orange no printing Feed to the cigar Lighter.

Brake Switch Connector (67) For 1967 vehicles; plug this connector to the 1967 Brake Lamp Switch.

17D White Brake SW Feed to the turn Signal Switch.

40H Orange 12V Battery-Fused Fused battery feed from the Fuse Block.

Brake Switch Connector (68-72) For 1968-1972 vehicles, plug this connector to the 1968-1972 Brake Lamp Switch.

17C,17D White Brake SW Feed to the turn Signal Switch

40A,40H Orange Brake SW Fused Battery feed from the Fuse Block

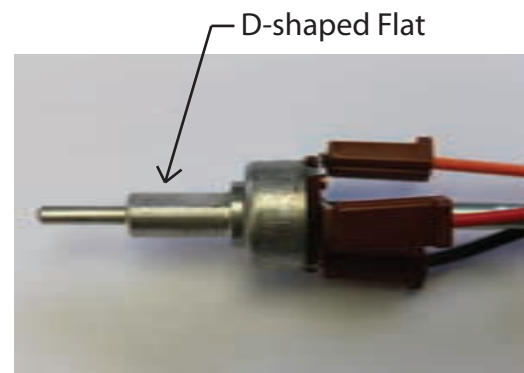

Figure G

Circuit Branch 7 - Under Dash Connections

Hazard Switch Connector Connect to the Hazard Switch. All Hazard Switches are Dash Mounted near the Cigar Lighter except 1967-1969 trucks without A/C. It is in the Glove Box for those vehicles.

14B	Light Blue	Left Front Turn	Feed to the Left Front Turn Signal Lamp.
14C	Light Blue	Left Dash IND	Feed to the Left Turn Indicator Light.
15A	Dark Blue	Right Front Turn	Feed to the Turn Signal Switch.
15C	Dark Blue	Right Front Turn	Feed to the Right Front Turn Signal Lamp.
17A	White	Brake SW	Feed to the Turn Signal Switch.
17C	White	Brake SW	Feed from the Brake Switch.
27	Brown	Turn SW-Hazard	Feed from the Hazard Flasher.

Heater Blower Switch Connectors (67) For 1967 vehicles connect these 1-way connectors to the Heater Blower Switch (see figure G).

50A	Brown	Heater/AC Feed	Fused Ignition Feed from the Fuse Block. (This wire will be used as the 12v "Off/On" for any aftermarket heat or A/C system.)
51	Red	no printing	Heater Blower low speed.
52	Orange	no printing	Heater Blower high speed.

Heater Blower Switch Connector (1968-72) For 1968-1972 vehicles, connect this 4-way connector to the Heater Blower Switch.

50,50A	Brown	Heater/AC Feed	Fused Ignition Feed from the Fuse Block.
51,51A	Red	no printing	Heater Blower low speed.
52,52A	Orange	no printing	Heater Blower high speed.
72	Light Blue	no printing	Heater Blower medium speed.

Heater Switch Illumination Lamp Connector Plug this connector to the Heater Switch Illumination Lamp Assembly.

8C,8D Gray Dash Lights Feed to the Heater Switch Illumination Lamp

Radio/Clock Connection

43	Tan	Radio	12V fused Accessory feed for Radio "on/off" power.
99	Yellow	Clock Battery	12V fused Battery feed for Radio memory or a Clock.
8D	Gray	Dash Lights	Dash Light feed for the Radio or Clock.

Circuit Branch 8 -Under Dash Connections

Right Hand Courtesy Lamp Connector Plug in one Under Dash Courtesy Lamp Extension from bag G (as shown on page 2) to complete this circuit and attach to the Lower Instrument Panel.

53B,53E Light Blue 12V CTSY SW Feed to the Right Hand Courtesy Lamp.

156B White CTSY Ground RH Courtesy Lamp ground. Attach this ring terminal to a good chassis ground.

Right Hand Door Jamb Switch Connection Route the two bullet terminals through the Door Jamb switch hole from behind, and connect to the Door Jamb Switch Y (located in kit 510376). Polarity does not matter. Attach the Door Jamb switch to the original mounting bracket.

40F Orange 12V Battery-Fused 12V Fused Battery feed.

53E Light Blue 12V CTSY SW Feed to the Courtesy and Dome Lights.

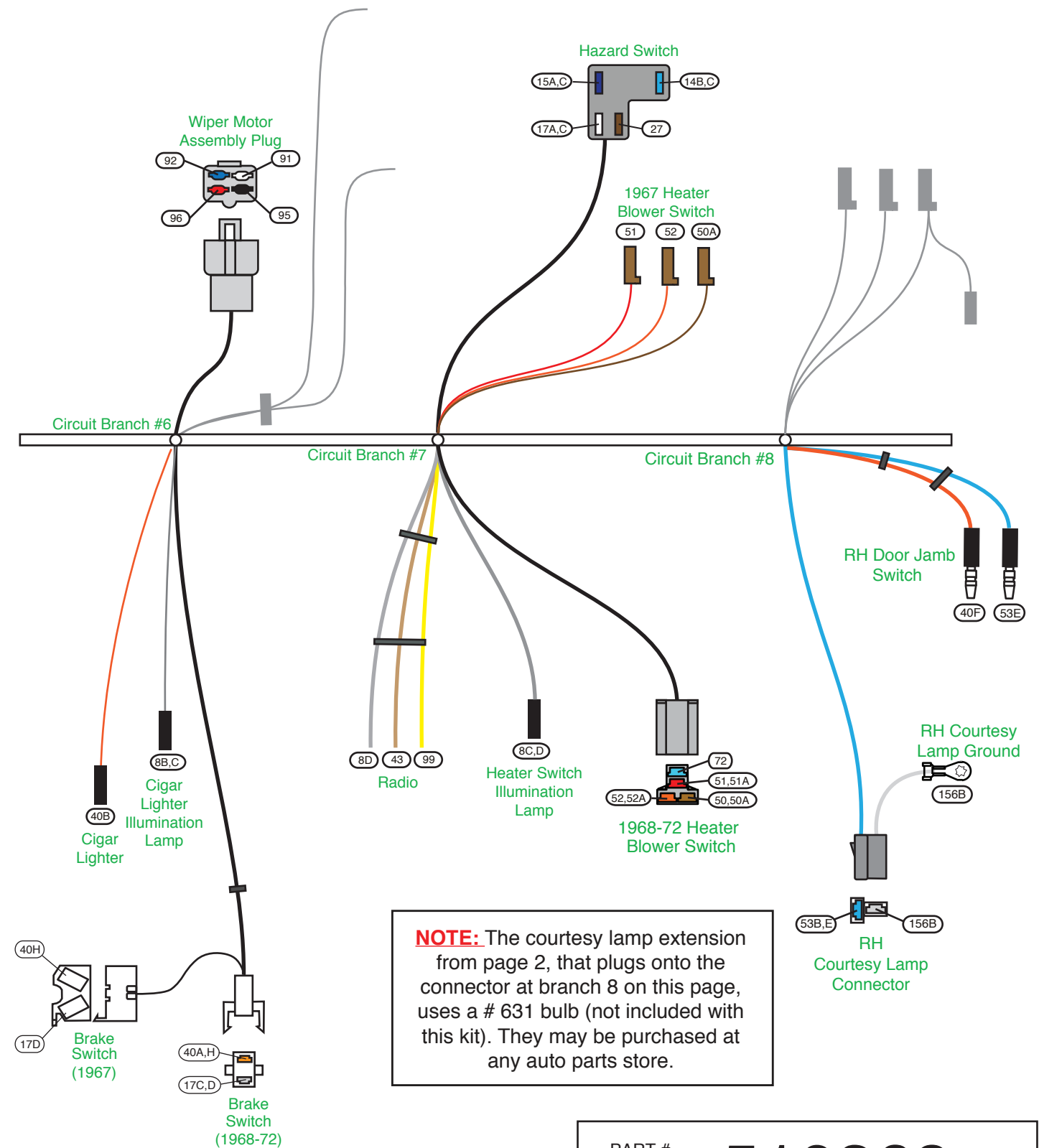

NOTE: The courtesy lamp extension from page 2, that plugs onto the connector at branch 8 on this page, uses a # 631 bulb (not included with this kit). They may be purchased at any auto parts store.



American Autowire

www.americanautowire.com 856-933-0801

PART # **510368**
 DESCRIPTION:
1967-72 Ford Truck Classic Update Series Kit
 92970307 Rev. 6.0 8/25/2016

Dash/Main Harness Installation Instructions

Circuit Branch 8 - Under Dash Connections

Blower Resistor Connectors Plug onto the blower Resistor see Figure J. Circuit 72 is not required for 1967 vehicles.

51A	Red	no printing	Heater Blower low speed, all years.
52A,52B	Orange	no printing	Heater Blower high speed, all years.
72	Light Blue	no printing	Heater Blower medium speed 1968-1972.

Blower Motor Connector Connect to the Blower Motor Pigtail.

52B	Black	no printing	Blower Motor feed.
-----	-------	-------------	--------------------

Circuit Branch 9 - Under Hood Connections RH Engine Compartment (Passenger Side) See page 11 Figure A for typical connections. For loose piece terminals and connectors, see parts kit 510376.

Starter Relay Connections Route wires 2A and 6 to the Starter Motor Relay location. See page 2 for the separate wire harnesses.

Alternator Output Circuit Obtain the Alternator Power Wire and Fusible Link Assembly (see page 2) from bag G and connect the ring terminal end (2H) with the blue fusible link to the battery terminal on the Starter Motor Relay. Route the other end (2) to the Alternator Battery stud, slide on sleeve D (from kit 510376) and install terminal L and attach this completed assembly to the battery stud of the Alternator (see page 11 figure D).

Wire#	Wire Color	Printing	Procedure
2	Red	no printing	Alternator output wire.
2H	Light Blue	Fusible Link	This is the Circuit protection for the Alternator output.

Main Power Feed to the Fuse Block Route wire 2A to the Starter Relay and cut to length. Install terminal C and insert into connector E (parts found in kit 510376) as shown on page 11. Obtain the Main Power Feed Fusible Link (see page 2) and plug into the same connector E (wire 2A). Now attach the eyelet end of the Main Power Feed Fusible Link (wire 2J) to the battery terminal of the starter relay (see page 11 figure D).

2A	Red	12V Battery	Main power feed.
2J	Brown	Fusible Link	This is the Circuit protection for the main power output.

Start Circuit Route wire 6 to the Starter Relay and cut to length. Install sleeve D and crimp on terminal K (see parts kit 510376). Connect to the Starter relay S stud (see page 11, figure A).

6	Purple	Starter Solenoid-S	Start circuit.
---	--------	--------------------	----------------

Ignition Feed, Alternator Exciter Wire and Tachometer See page 11, figure A for typical connections.

Alternator Exciter Wire The wire 4D is the exciter wire for your alternator/voltage regulator. If you are using a one wire alternator, this wire will not be used and should be capped off as it is "hot" in the ignition "on" position. If you are using an alternator that requires an internal or external voltage regulator, this wire must be connected to the "switched or 12V ignition" terminal on your regulator or alternator according to the manufacturers specifications for the type of alternator/regulator that is being used. An inline diode or resistor may be necessary to eliminate "run on" after being switched off. AAW recommends a GEN 3 Internally Regulated or one wire alternator. If you are using a GM "SI" alternator, obtain the GM "SI" Alternator Exciter Wiring Harness (see page 2) from Bag G. Attach the eyelet end of wire 2G to the Alternator Battery stud (see figure D page 11). Route the 4D wire to the 2-way connector, which is part of the same Exciter Wiring Harness. Crimp on terminal B to wire 4D and insert into the open cavity of the 2-way connector. Now plug the 2-way connector into the "SI" alternator.

2G	Red	12V Battery	Battery wire for the GM "S" Alternator Exciter Wiring Harness.
4D	Brown	Alternator IGN	Alternator Exciter wire.

Headlights Install Grommet Z in the RH Radiator Cor Support. Select the light green Headlight High Beam wire (11C) and the Low Beam wire (12A). Route these wires to the RH Headlight and cut to length, install terminal A, found in kit 510376, to each wire, and insert the wires into the Front Headlamp Extension Harness (see page 2) from Bag G. For proper circuit orientation, see page 11 Figure A.

11C	Light Green	Headlight-Hi Beam	High Beam feed to the RH Headlight.
12A	Tan	Headlight-Low Beam	Low Beam feed to the RH Headlight.

Front Headlamp Extension Harness This can be found in kit Bag G and is shown on page 2 and in figure A on page 11. The 150D ground wire ring terminal will attach to the original Headlamp ground wire location. The 150T female bullet ground wire will attach to the Park Lamp Assembly ground lead.

150D	Black	Ground	This is the Headlight Ground.
150T	Black	Ground	This is the Ground for the Park Lamp Assembly.

Right Hand Park/Turn Lamp & Socket Assembly NOTE: You will need to reuse the original Park/Turn Signal Lamp & Socket Assembly but will have to replace the 2-way bullet connector with a 2-way AAW connector (see figure A on page 11). Remove the old connector and crimp on terminals "W" (supplied in kit 510376) to the two wires and install the wires in the 2-way connector "V" (also supplied in kit 510376) as shown in figure A. The original Ford turn signal wire is white/blue (all years), the park lamp wire is black/yellow (67-69) or brown (70-72).

9A	Brown	Park Lights	Park Light feed.
15C	Dark Blue	Right Front Turn	Turn Signal feed.

Right Hand Park/turn Lamp Connector Select the brown Park Light wire (9A) and the dark blue Right Front Turn wire (15C). Route these wires to the RH Park/Turn Lamp and cut to length. Install terminal B, found in kit 510376, to each wire, and insert the wires into connector T. Be sure to align the AAW brown Park Light wire with the Ford Park Light wire (black/yellow or brown) and the AAW dark blue Right Front Turn wire with the Ford Right Front Turn wire (white/blue).

9A	Brown	Park Lights	Park Light feed.
15C	Dark Blue	Right Front Turn	Turn Signal feed.

Horn Connection Route wire (29) to the RH Horn and cut to length. If the vehicle has only one Horn (it will be on the right side of the radiator), crimp on terminal "B" and insert into connector "N" and attach to the RH Horn. If there are two horns, double the wire that was just cut with wire (29) and crimp on terminal "C" instead of "B" and insert into connector "N" and attach to the RH Horn. Route the loose wire to the LH Horn (which is on the left side of the radiator) and crimp on terminal "B" and insert into connector "N" and attach to the LH Horn. All of the terminals and connectors will be found in kit 510376.

29	Dark Green	Horn	Horn feed.
----	------------	------	------------

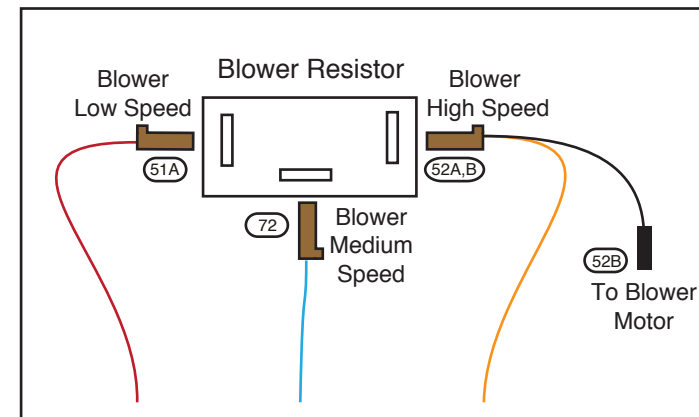
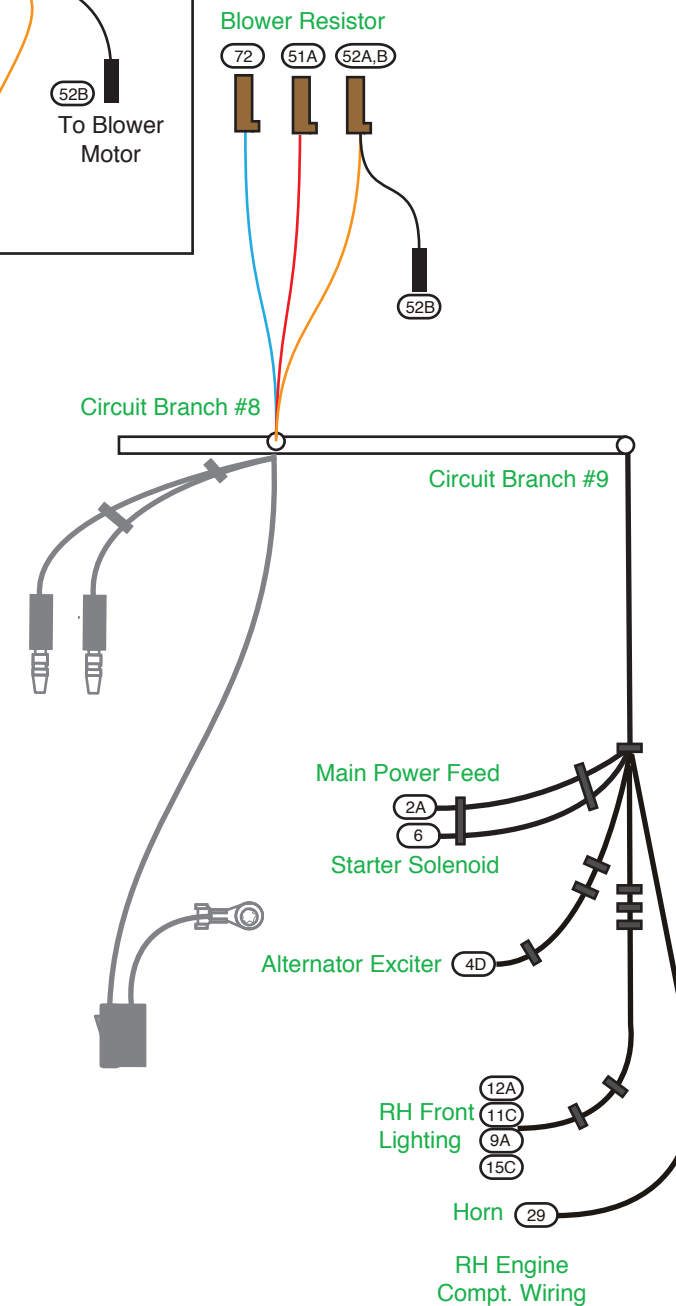

Figure J



www.americanautowire.com 856-933-0801

PART # **510368**
 DESCRIPTION:
**1967-72 Ford Truck
 Classic Update Series Kit**

92970307 Rev. 6.0 8/25/2016

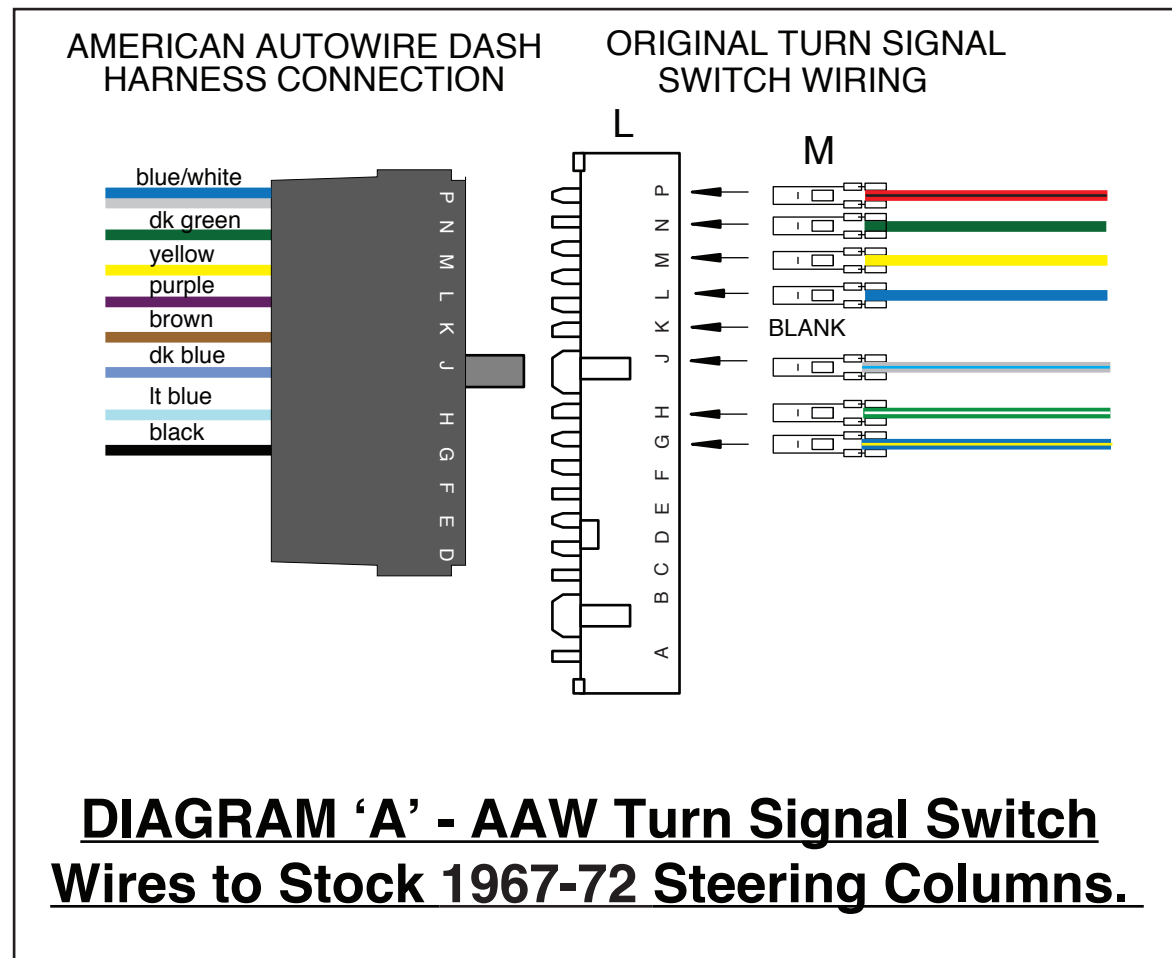

“Table A”

AAW Turn Signal Switch wires to stock 1967-72 Ford truck Turn Signal Switch

AAW Wire #	AAW Wire color	AAW Wire Printing	Ford Wire Color
14A,B	Light Blue	Left Front Turn	Green with white stripe.
15A,B	Dark Blue	Right Front Turn	White with blue stripe.
16	Purple	Turn Switch Feed	Blue.
17A,B	Blue & White	Brake Switch	Red with black stripe.
18	Yellow	Left Rear Turn	Yellow
19	Dark Green	Right Rear Turn	Dark Green
27	Brown	Turn SW - Hazard	not available
28	Black	Horn Relay Ground	Blue with yellow stripe.

NOTE: For these vehicles, the stock Ford steering column horn button switched ground to a horn relay just as the AAW system does. Also, for the 1969-1972 vehicles, Ford changed the Left Rear Turn circuit color from Yellow to Yellow with a black stripe. Circuit 27 is being provided if an Emergency Warning Flasher System is to be added.



www.americanautowire.com 856-933-0801

PART # **510368**

DESCRIPTION:
1967-72 Ford Truck
Classic Update Series Kit

92970307 Rev. 6.0 8/25/2016

Figure "A", Branches #6 and #9 Passenger's Side Location

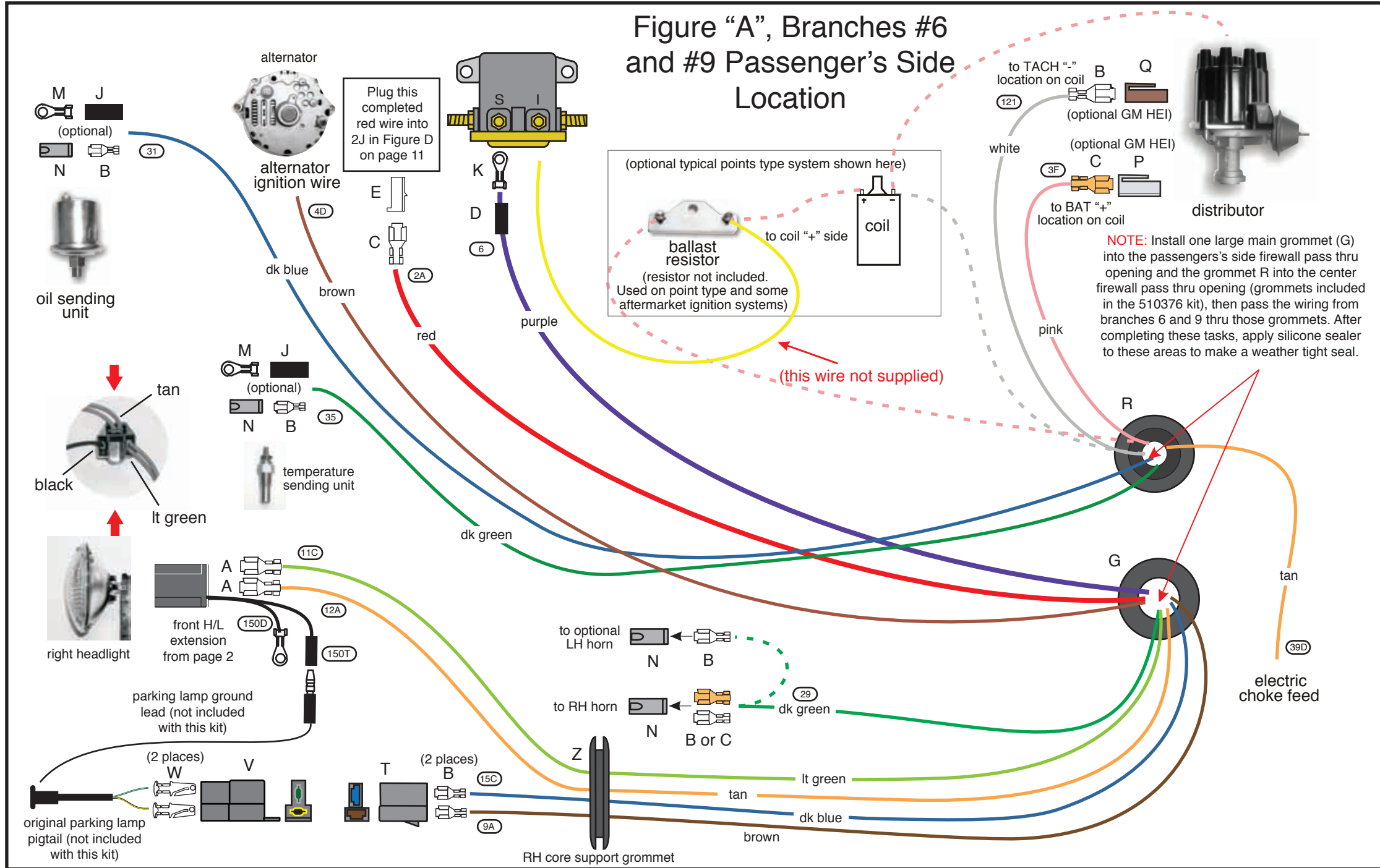

NOTE: The terminals and connectors listed on this page and denoted with **UPPER CASE LETTERS** are to help you complete the various connections to your lamps, engine connections, switches, horn, etc. They can all be found in your loose piece clamp, parts kit, P/N 510376.

AAW suggests and recommends using pages 7 and 9 to complete the installation of the RH forward lamp, turn, various engine functions, horn, starter solenoid, tachometer, alternator exciter and power connections, and the main power feed.

AAW kits are all engineered to be used in conjunction with a high output, later model internally regulated, or one wire alternator. We do not suggest or support the use of a stock low amperage alternator as they do not supply sufficient current to recharge the battery in a highly modified truck such as this kit was designed for. AAW suggests a Ford Gen III, a GM "SI", or a 1 wire type alternator as good choices to use. An adapter to complete the connection to the Ford Gen III style alternator (AAW p/n 500802) may be purchased separately. Contact AAW for your needs.

Main system power feed and alternator connections.

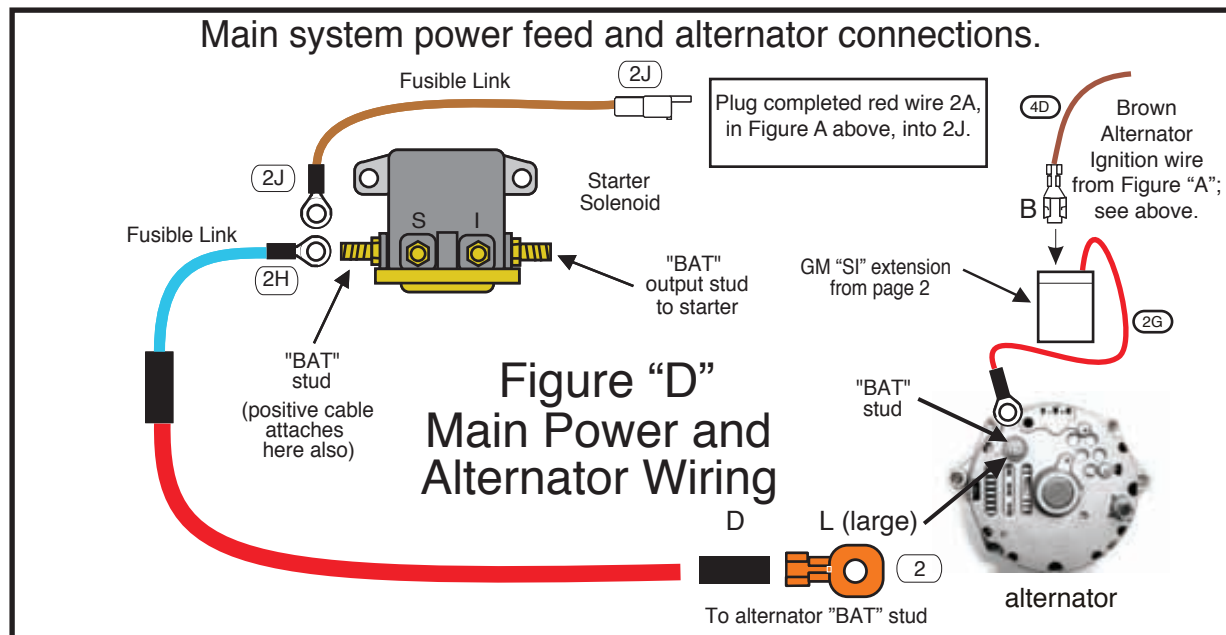

RH headlamp, RH parking lamp, engine, main power, tachometer, alternator ignition and power, horn, and starter solenoid connections.

These wires are all found at branches 6 and 9 on pages 7 and 9



www.americanautowire.com 856-933-0801

PART # **510368**
 DESCRIPTION:
1967-72 Ford Truck Classic Update Series Kit

92970307 Rev. 6.0 8/25/2016

**Figure "C", Branch #2
Driver's Side Location**

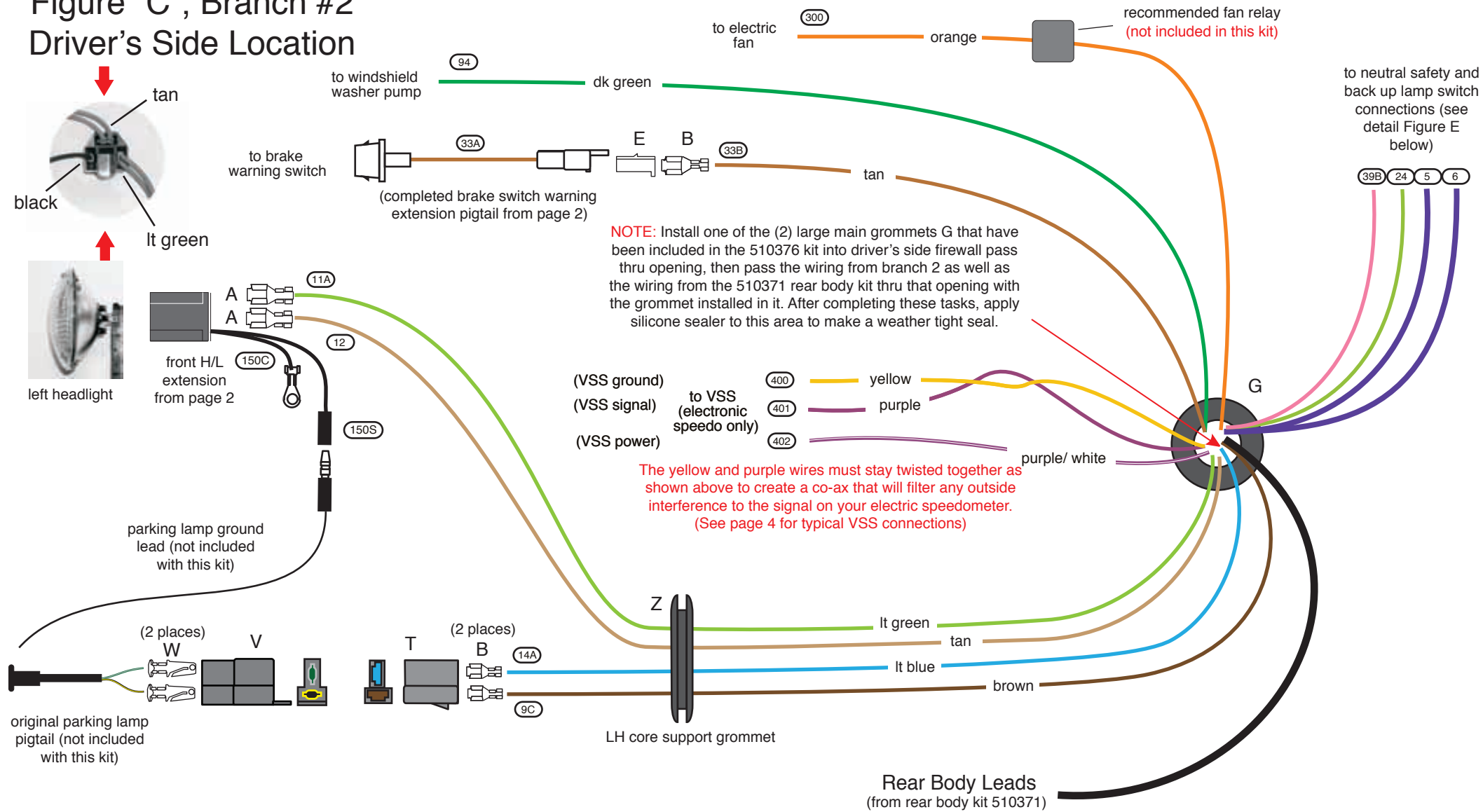

NOTE: The terminals and connectors listed on this page and denoted with **UPPER CASE LETTERS** are to help you complete the various connections to your lamps, brake warning switch, electric fan, back up and neutral safety switch, washer pump, etc. They can all be found in your loose piece, grommet, and parts kit, P/N 510376. No terminals are provided for the neutral safety or back up switch connections.

AAW suggests and recommends using pages 3, & 4 to complete the installation of the LH forward lamp, turn, brake warning switch, electric fan, washer pump, neutral safety and back up switch.

This AAW kit is engineered to work with a stock heater system and most aftermarket manufacturer's heating and air conditioning systems. As such, we have provided a keyed 12-volt feed (see Branch 7) to use as the "OFF / ON" (AAW brown 50A wire) power source for whatever system you choose to purchase. The manufacturer will supply you with a harness for their system and instructions on how to connect it.

Figure "E"
Shown is a typical NSS and Back Up Switch.

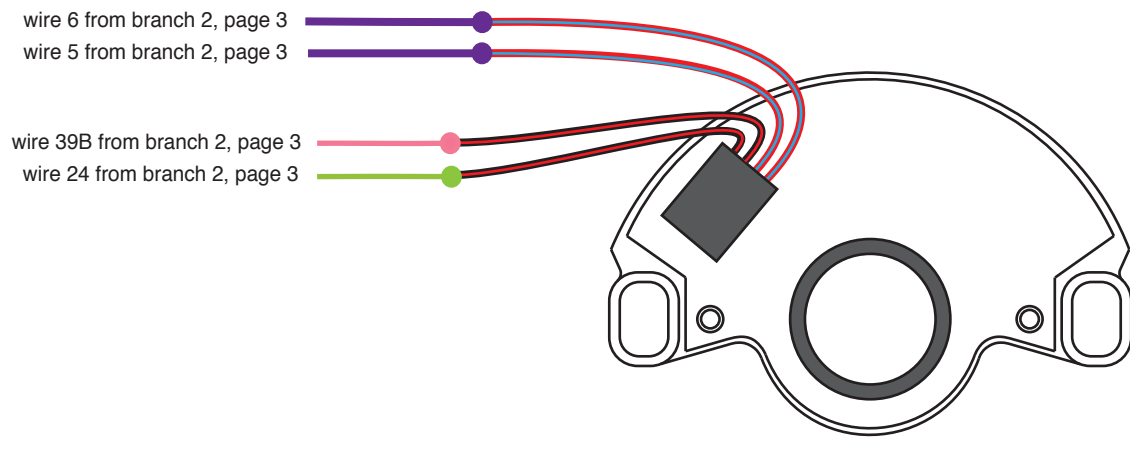

LH headlamp, LH parking lamp, washer, brake switch, electric fan relay trigger, neutral safety, and back up connections.

These wires are all found at branch 2, pages 3 and 4



www.americanautowire.com 856-933-0801

PART # **510368**
DESCRIPTION:
**1967-72 Ford Truck
Classic Update Series Kit**

92970307 Rev. 6.0 8/25/2016

FUSE AND FLASHER LOCATIONS

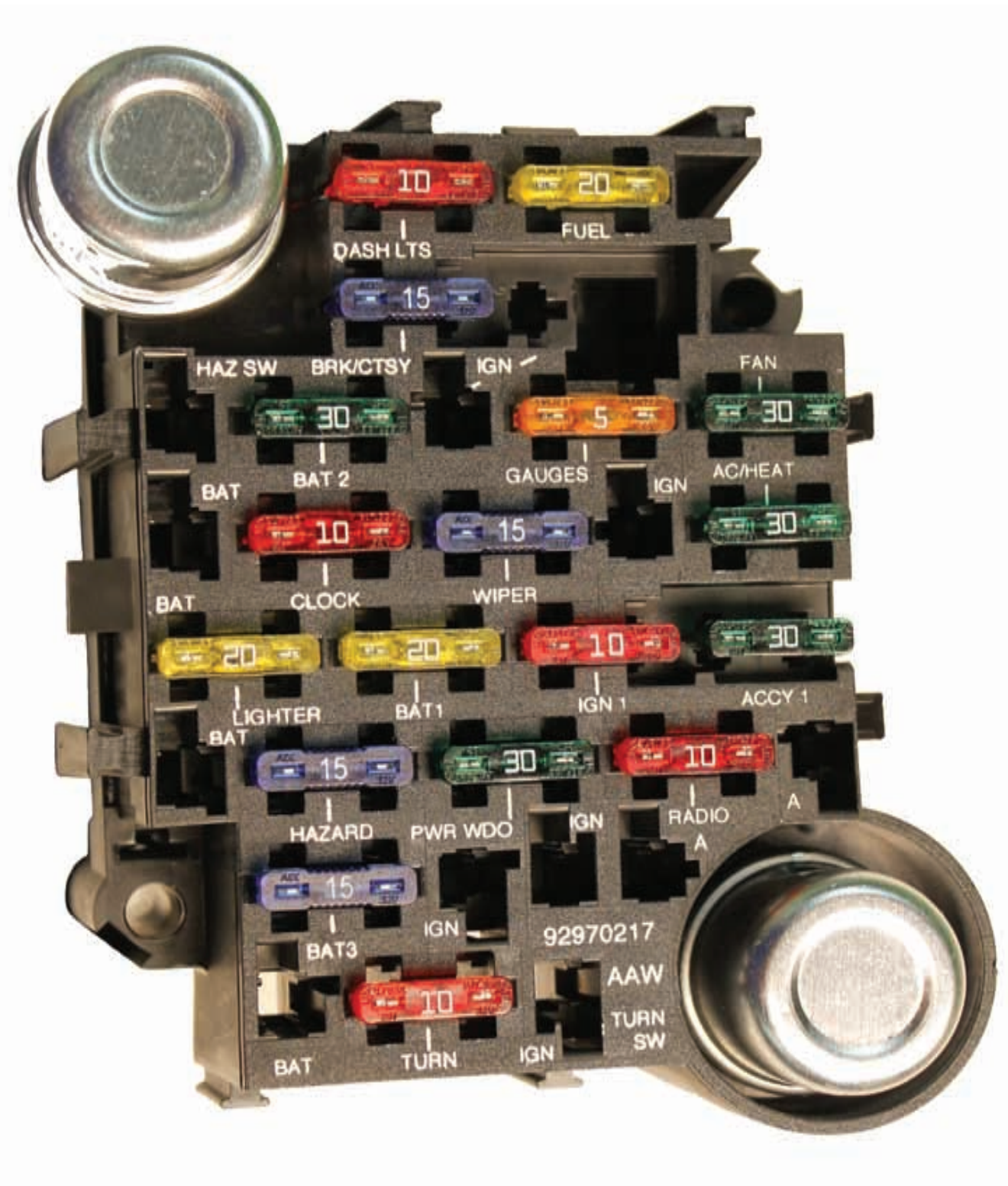

NOTE: Above, you will find a photograph of the completed Fuse Block assembly depicting the proper location for the installation of each fuse and the two flasher cans.



www.americanautowire.com 856-933-0801

PART # **510368**
 DESCRIPTION:
 1967-72 Ford Truck
 Classic Update Series Kit

92970307 Rev. 6.0 8/25/2016

This page intentionally left blank.



www.americanautowire.com 856-933-0801

PART # **510368**
DESCRIPTION:
1967-72 Ford Truck
Classic Update Series Kit

92970307 Rev. 6.0 8/25/2016