

**1969 Firebird and  
1968 - 1970  
GTO, Tempest, and  
Le Mans**

**NOTE:** Wiper connections are shown on pages 5 and 6 of this instruction set.

**NOTE:** In **1969 Firebird** applications with an automatic transmission and a carburetor mounted kick-down switch, you will need to order AAW kick-down harness CA89365 separately. It will piggy-back between the wiper connections and the kick-down switch, to activate the transmission switch.



www.americanautowire.com 856-933-0801

Classic Update Series **J**

1969 Pontiac Firebird and  
1968-72 Pontiac GTO  
**ENGINE KIT**  
**510543**

92970638 Rev 1.0 11/3/2015

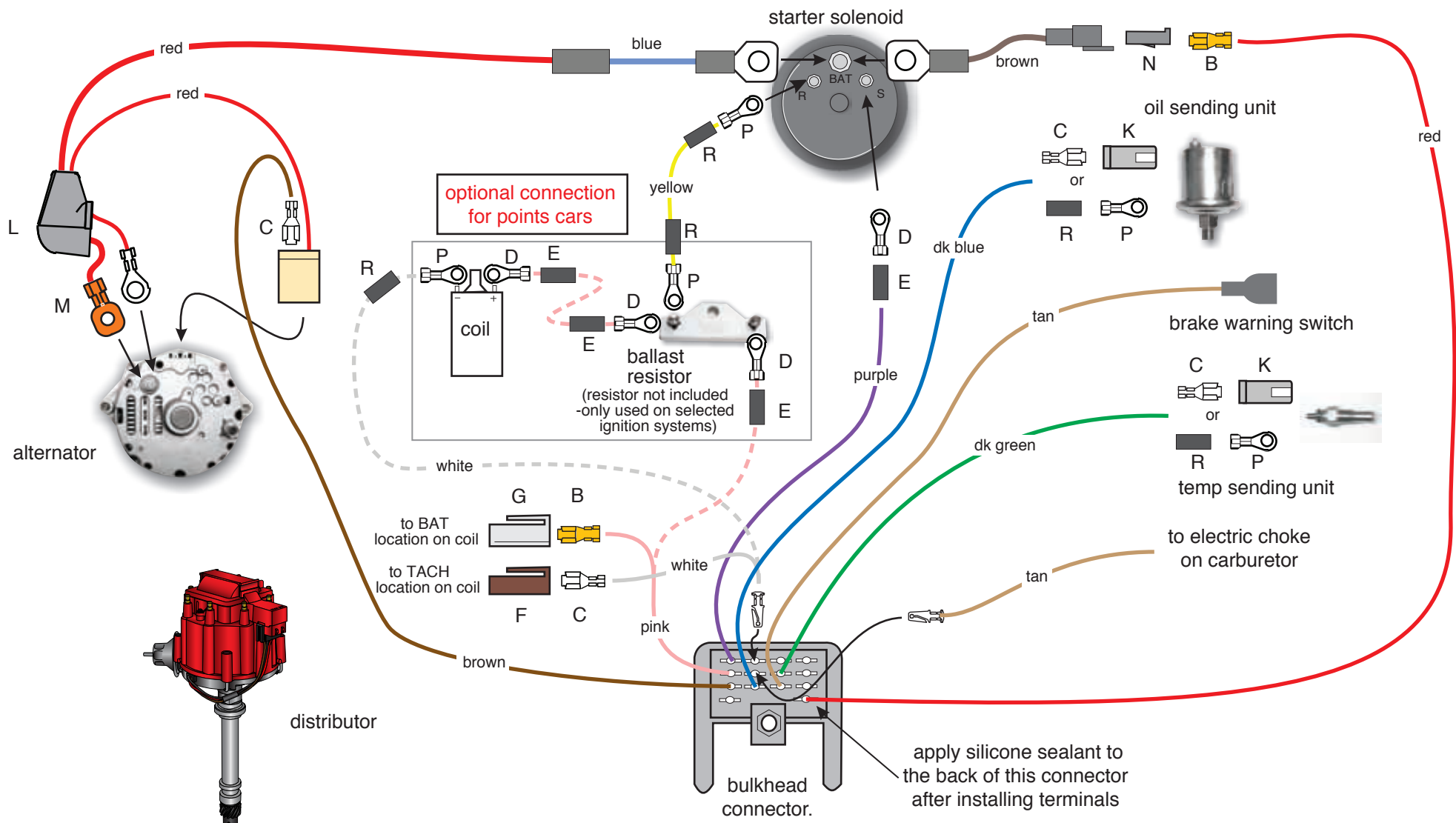

**1971 - 1972**  
**GTO, Tempest, and**  
**Le Mans**

**NOTE:** Wiper connections  
 are shown on page 5 of  
 this instruction set.



www.americanautowire.com 856-933-0801

**ENGINE KIT**  
**510543**  
 92970638 Rev 1.0 11/3/2015

TEMPORARILY, PLUG THE MAIN BULKHEAD CONNECTOR FROM THIS KIT INTO THE MATING CONNECTOR ON THE DASH BULKHEAD CONNECTOR (LOCATED UNDER THE MASTER CYLINDER) Note: This will be unbolted to install the front light harness later.

**LOOSE PIECE WIRE:**

YELLOW (no printing)

**(1968-70 GTO and 1969 Firebird applications) If using a points type ignition system:**

Install this loose wire into main connector as shown on page 1 of this instruction set. Route this YELLOW wire to the coil side of the ballast resistor (not included with this kit), cut to length, install rubber sleeve R and ring terminal P, and connect it the coil side of the ballast resistor as shown on page 1 of this instruction set.

**(1968-70 GTO and 1969 Firebird applications) If using an HEI type ignition system:**

Install this loose wire into main connector as shown on page 1 of this instruction set. Route this YELLOW wire to the coil, trim to length, double it with the pink wire from below, install terminal B and connector G, then plug into the distributor cap "BAT" location as shown on page 1 of this instruction set.

**(1968-70 GTO and 1969 Firebird applications) If using an aftermarket type 12v ignition system:**

Install this loose wire into main connector as shown on page 1 of this instruction set. Route this YELLOW wire to the 12v ignition connection location of your ignition system, trim to length, double it with the PINK wire from below, then connect it to the 12v ignition connection of your system (consult the ignition system manufacturer's instructions for specific installation procedures).

**(1971-72 GTO applications) If using a points type ignition system:**

Cut the male terminal off of this loose piece wire, install rubber sleeve R and ring terminal P on one end of the wire and connect it to the "R" terminal on your starter solenoid. Route the loose end of this YELLOW wire back up to your ballast resistor, cut to length, install rubber sleeve R and ring terminal P on the end of the wire, and connect it to the coil side of the ballast resistor (not included with this kit) as shown on page 2 of this instruction set.

**(1971-72 GTO applications) This YELLOW wire will not be used in an HEI or aftermarket type 12v ignition system.**

**BULKHEAD CONNECTOR WIRES:**

PINK (12 V IGNITION)

**(1968-70 GTO and 1969 Firebird applications) If using a points type ignition system:**

Route the PINK wire to the ignition feed side of a ballast resistor (not included), cut to length, install rubber sleeve E and ring terminal D, and connect it to the ignition feed side of the ballast resistor as shown on page 1 of this instruction set. Install rubber sleeve E and ring terminal D onto the cut-off portion of this wire and connect it to the coil side of the ballast resistor (along with the yellow bypass wire from above) as shown on page 1 of this instruction set. Route the loose end of this wire to the positive post of the coil, cut to length, install rubber sleeve E and ring terminal D on that end of the wire, and install it onto the positive (+) post of the coil.

**(1968-70 GTO and 1969 Firebird applications) If using an HEI type ignition system:**

Route this PINK wire to the coil, trim to length, double it with the YELLOW wire from above, install terminal B and connector G, then plug into the distributor cap "BAT" location as shown on page 1 of this instruction set.

**(1968-70 GTO and 1969 Firebird applications) If using an aftermarket type 12v ignition system:**

Route this PINK wire to the 12v ignition connection location of your ignition system, trim to length, double it with the YELLOW wire from above, then connect it to the 12v ignition connection of your system (consult the ignition system manufacturer's instructions for specific installation procedures).

**(1971-72 GTO applications) If using a points type ignition system:**

Route the PINK wire to the ignition feed side of a ballast resistor (not included), cut to length, install rubber sleeve E and ring terminal D, and connect it to the ignition feed side of the ballast resistor as shown on page 2 of this instruction set. Install rubber sleeve E and ring terminal D onto the cut-off portion of this wire and connect it to the coil side of the ballast resistor (along with the yellow bypass wire from above) as shown on page 2 of this instruction set. Route the loose end of this wire to the positive post of the coil, cut to length, install rubber sleeve E and ring terminal D on that end of the wire, and install it onto the positive (+) post of the coil as shown on page 2 of this instruction set.

**(1971-72 GTO applications) If using an HEI type ignition system:**

Route this PINK wire to the coil, trim to length, install terminal B and connector G, then plug into the distributor cap "BAT" location as shown on page 2 of this instruction set.

**(1971-72 GTO applications) If using an aftermarket type 12v ignition system:**

Route this PINK wire to the 12v ignition connection location of your ignition system, trim to length, then connect it to the 12v ignition connection of your system (consult the ignition system manufacturer's instructions for specific installation procedures).

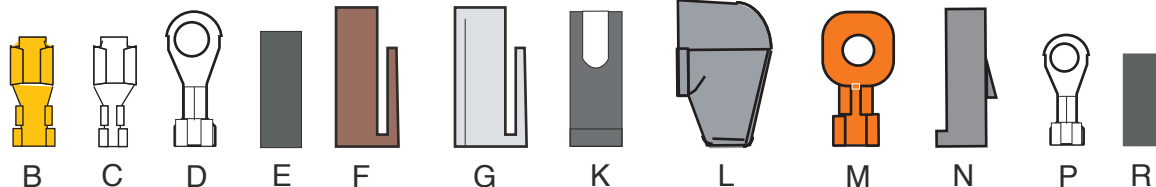

www.americanautowire.com 856-933-0801

ENGINE KIT  
510543

92970638 Rev 1.0 11/3/2015

### **BULKHEAD CONNECTOR WIRES (CONT'D):**

RED	(12 V BATTERY)	Route this RED wire to the starter solenoid and cut to length. Install terminal B and solder, then plug into connector N as shown on page 1 or page 2 of this instruction set.
BROWN	(fuse link wire)	Connect to the battery stud on the starter solenoid and plug the other end into the RED wire as shown on page 1 or page 2 of this instruction set.
PURPLE	(STARTER SOLENOID)	Route this PURPLE wire to the starter solenoid and cut to length. Install rubber sleeve E and ring terminal D. Connect to the "S" terminal on the solenoid as shown on page 1 or page 2 of this instruction set.
DARK BLUE	(OIL PRESSURE SENDER)	Route this DK. BLUE wire to the oil pressure sending unit, cut to length, install rubber sleeve R and ring terminal P or terminal C together with connector K, then connect it to the sending unit as shown on page 1 or page 2 of this instruction set.
DARK GREEN	(WATER TEMP SENDER)	Route this DK. GREEN wire to the temperature sending unit, cut to length, install rubber sleeve R and ring terminal P or terminal C together with connector K, then connect it to the sending unit as shown on page 1 or page 2 of this instruction set.
TAN	(BRAKE LIGHT SWITCH)	Route and connect this TAN wire to the brake pressure differential switch as shown on page 1 or page 2 of this instruction set. No other process is necessary as this wire has already been pre-terminated for you.
BROWN	(ALTERNATOR IGN)	This is your alternator regulator exciter wire. If using a 1-wire alternator, this wire can be removed from the main connector, as it will not be used. If using with a GM "SI" internally regulated alternator, route this BROWN wire to the alternator, cut to length, and install terminal C. This wire will plug into the empty cavity in the off white alternator connector that has the SMALL RED wire already installed into it from below. Do not install this BROWN wire yet.

### **LOOSE PIECE WIRES:**

TAN	(ELECTRIC CHOKE)	Install this loose wire into main connector as shown on page 1 or page 2 of this instruction set, then route and connect this wire to your electric choke.
WHITE	(COIL-TACH)	<b>(Used only with an aftermarket tach. If your car is equipped with a factory tach, you must purchase an AAW factory tach harness for your specific application. For GTO applications, see 510542 Bag H, for all of the different applications and part numbers, for Firebird applications, see 510624 Bag H, for all of the different applications and part numbers)</b> Install this loose wire into main connector as shown on page 1 or page 2 of this instruction set, then route this WHITE wire to the coil and trim to length. If using an HEI distributor, install terminal C and connector F and then plug into the distributor cap "TACH" location. If using a conventional coil, install rubber sleeve R and ring terminal P and connect to the negative (-) post of the coil.

### **ALTERNATOR WIRES:**

HEAVY RED	(AMERICAN AUTOWIRE)	Connect the blue fuse-link wire to the battery stud on the starter solenoid. Route the other end to the alternator and trim to length. Install boot L and terminal M and connect to the battery stud on the alternator as shown on page 1 or page 2 of this instruction set.
SMALL RED	(no printing)	(Used only with a GM "SI" internally regulated alternator [except a 1-wire]) Send the ring terminal end of this wire through boot L as shown on page 1 or page 2 of this instruction set, and connect to the battery stud on the alternator. Install the BROWN exciter wire from above into the empty cavity of this connector and then plug this connector into the alternator as shown on page 1 or page 2 of this instruction set.

**NOTE:** See page 5 or 6 for the wiper washer wire connections as they apply to either page 1 or page 2.

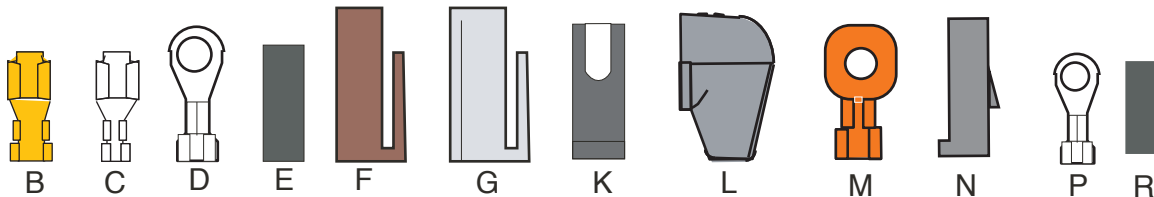

**ENGINE KIT**  
**510543**



## 1968-1972 Pontiac GTO, Tempest and Le Mans models with 2 speed wipers and washers

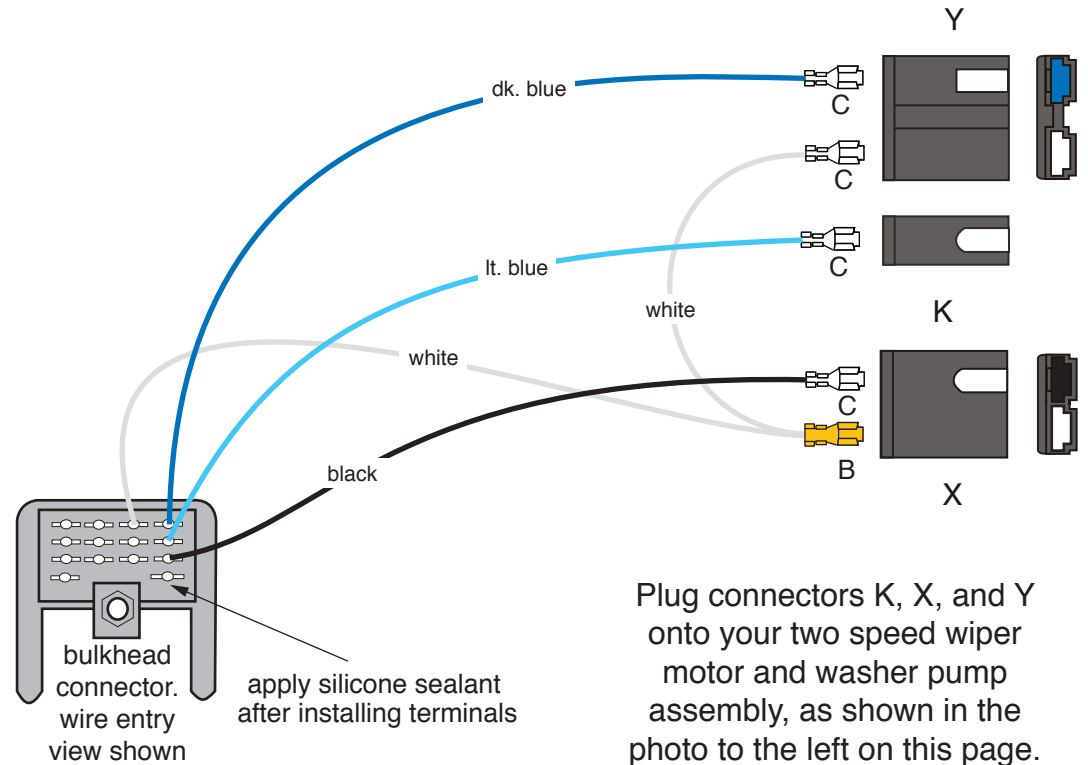

Plug connectors K, X, and Y onto your two speed wiper motor and washer pump assembly, as shown in the photo to the left on this page.

**WHITE** (wiper feed)  
(original black/yellow in photo)

Route this wire to the wiper motor, trim to length, double this wire with the cut-off portion, install terminal B, and plug into connector X as shown on this page. Route the remaining portion to the washer pump, trim to length, install terminal C and plug into connector Y as shown on this page.

**BLACK** (wiper low speed)  
(original black/white in photo)

Route this wire to the wiper motor, trim to length, install terminal C, and plug into connector X as shown on this page.

**LT. BLUE** (wiper high speed)  
(original lt. blue/black in photo)

Route this wire to the wiper motor, trim to length, install terminal C, and plug into connector K as shown on this page.

**DK. BLUE** (washer)  
(original dk. blue/white in photo)

Route this wire to the washer pump, trim to length, install terminal C, and plug into connector Y as shown on this page.

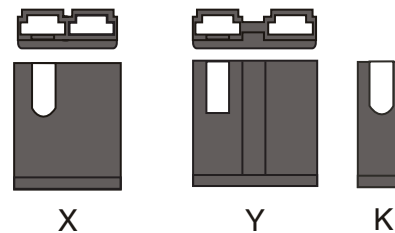

**1968-1972 TWO SPEED WITH WASHER PUMP CONNECTIONS**



**ENGINE KIT**  
**510543**



## 1969 Pontiac Firebird models with 2 speed wipers and washers

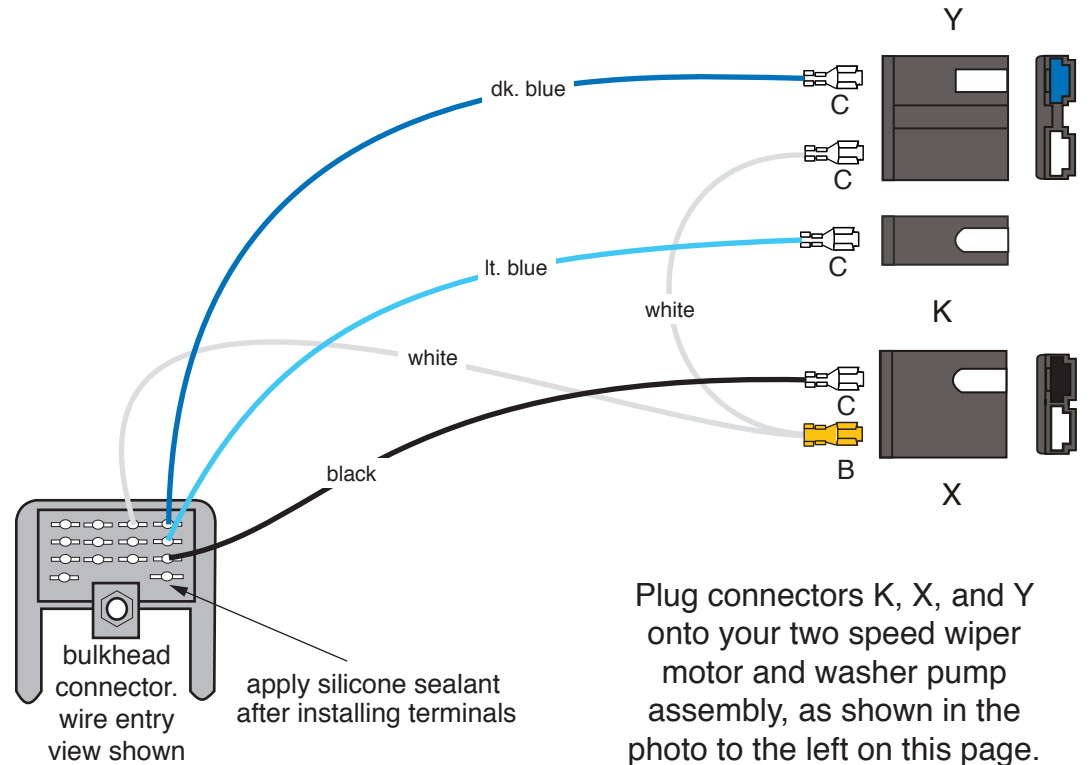

Plug connectors K, X, and Y onto your two speed wiper motor and washer pump assembly, as shown in the photo to the left on this page.

**WHITE** (wiper feed)  
(original black/yellow in photo)

Route this wire to the wiper motor, trim to length, double this wire with the cut-off portion, install terminal B, and plug into connector X as shown on this page. Route the remaining portion to the washer pump, trim to length, install terminal C and plug into connector Y as shown on this page.

**BLACK** (wiper low speed)  
(original black/white in photo)

Route this wire to the wiper motor, trim to length, install terminal C, and plug into connector X as shown on this page.

**LT. BLUE** (wiper high speed)  
(original black/lt. blue in photo)

Route this wire to the wiper motor, trim to length, install terminal C, and plug into connector K as shown on this page.

**DK. BLUE** (washer)  
(original dk. blue/white in photo)

Route this wire to the washer pump, trim to length, install terminal C, and plug into connector Y as shown on this page.

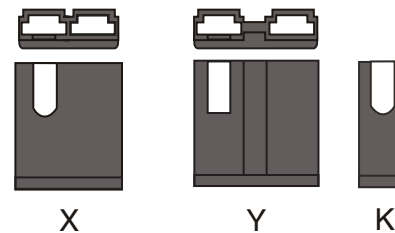

**1969 TWO  
SPEED WITH  
WASHER PUMP  
CONNECTIONS**



**ENGINE KIT  
510543**