

Classic Update Series

60-64 Ford Galaxie and 61-64 Mercury Full-size

START HERE !

PLEASE READ THIS BEFORE STARTING INSTALLATION !

This wiring kit is designed for ease of installation. Please read the guidelines below, BEFORE STARTING your installation to guarantee a successful job. Use an appropriate crimping tool which folds the wings of the open barrel terminals down into the wire as shown below. ALL TERMINALS THAT YOU INSTALL SHOULD BE PROPERLY SOLDERED. Our factory crimped terminations are installed by GM approved five ton presses, and soldering these terminations is not necessary. AAW offers a great terminal crimping video entitled "Proper Crimping Video". It can be viewed by visiting YouTube. Type the following address into your web browser to go directly to the video: www.youtube.com/watch?v=8u_EkMsioMy.



PLEASE READ THESE HELPFUL INSTALLATION TIPS BEFORE GOING ANY FURTHER!

Prior to installing the Dash/Main harness in your vehicle, plug all of the fuses (see a detailed picture, on page 18, of the fuse installation locations) and Horn Relay (see page 9), into this harness.

AS THIS HARNESS IS DESIGNED FOR USE IN A MODIFIED VEHICLE REQUIRING A HIGHER RATE OF CHARGE, IT DOES NOT SUPPORT THE USE OF A STOCK (ORIGINAL) ALTERNATOR. IT IS DESIGNED FOR USE WITH AN INTERNALLY REGULATED GM "SI" STYLE OR SINGLE WIRE STYLE ALTERNATOR. ADAPTERS (WHICH ARE NOT INCLUDED WITH THIS KIT) THAT ARE AVAILABLE FROM SEVERAL SOURCES WILL BE NECESSARY TO USE ANY ALTERNATOR OTHER THAN A GM "SI" STYLE OR SINGLE WIRE STYLE UNIT.

STEP 1: DISCONNECT YOUR BATTERY:

Disconnect the battery before installing the wiring kit to prevent any accidental shorting caused by loose bare wire ends.

STEP 2: START INSTALLING KIT (see page 3):

This kit is broken down into individual steps that are identified by a letter printed on the instruction sheets visible through each bag. These letters are the order of operation for installing your kit. Start with bag letter G, then H, etc. The order of installation is shown below. You will use this main instruction sheet, 92971132, to complete the installation process of bag G. See page five of this instruction set and Fuse Block Mounting instruction sheet 92971155 to begin.

- G - 510592 Dash Harness Kit
- H - 510593 Gauge Cluster Kit
- M - 510594 Rear Body Kit
- N - 510595 Headlight Harness Kit

STEP 3: RECONNECT YOUR BATTERY:

When you have completed the installation and are ready to reconnect the battery, make sure that the following electrical system grounds are in place:

- A. Battery is grounded to the ENGINE BLOCK.
- B. Battery is grounded to the frame.
- C. Engine block is grounded to the frame.
- D. Body is grounded to the frame.

STEP 4: CHECK ALL ELECTRICAL FUNCTIONS:

Any non-functioning items should be checked for proper installation. Any problems with your wiring and electrical circuit functions should be addressed to American Autowire Systems, Inc. as soon as possible to avoid any warranty problems.

If you have any questions concerning this or any of our products, please feel free to call us at 1-856-933-0801.

AMERICAN AUTOWIRE MAKES IT EASY !!

We carry many accessories for your 60-64 Ford Galaxie and 61-64 Mercury Full-size

p/n 510585
OEM small terminal crimping
tool (18-14 gauge)



p/n 510586
OEM large terminal crimping
tool (12-8 gauge)



p/n 500918
Ford Duraspark Ignition Harness



p/n 500802
GM "SI" series to Ford "3G" int.
regulated alternator



www.americanautowire.com 856-933-0801

Classic Update Series
1960-64 Ford Galaxie
1961-64 Mercury Full-Size

510591

© COPYRIGHT 2004 American Autowire / Factory-Fit
Used with express permission of
American Autowire / Factory-Fit

92971132 Rev. 0.0 4/16/2015

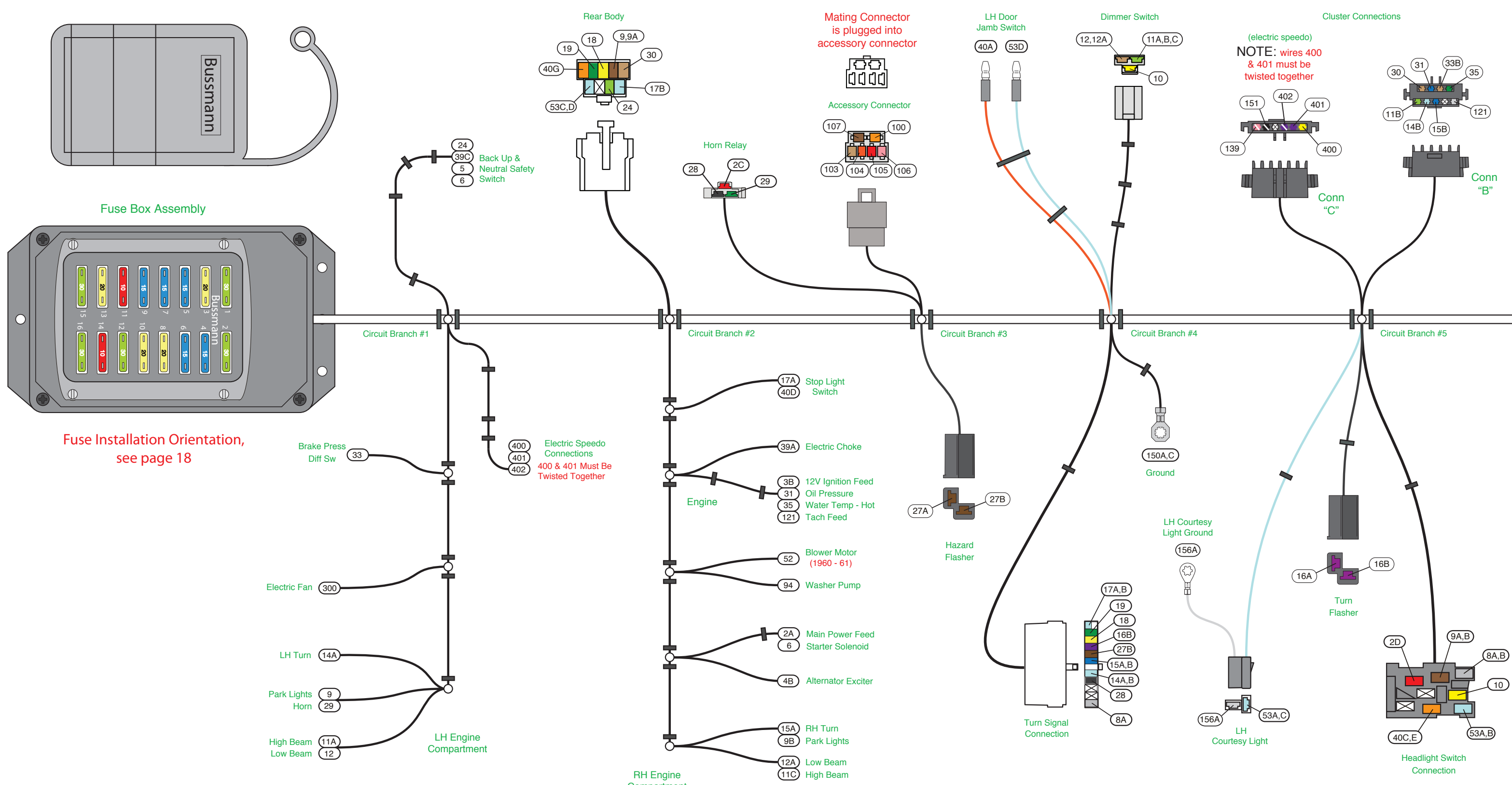

www.americanautowire.com 856-933-0801

PART # **510591**

DESCRIPTION:
 1960-64 Ford Galaxie
 1961-64 Mercury Full-size
 Classic Update Series Kit

92971132 Rev. 0.0 4/16/2015

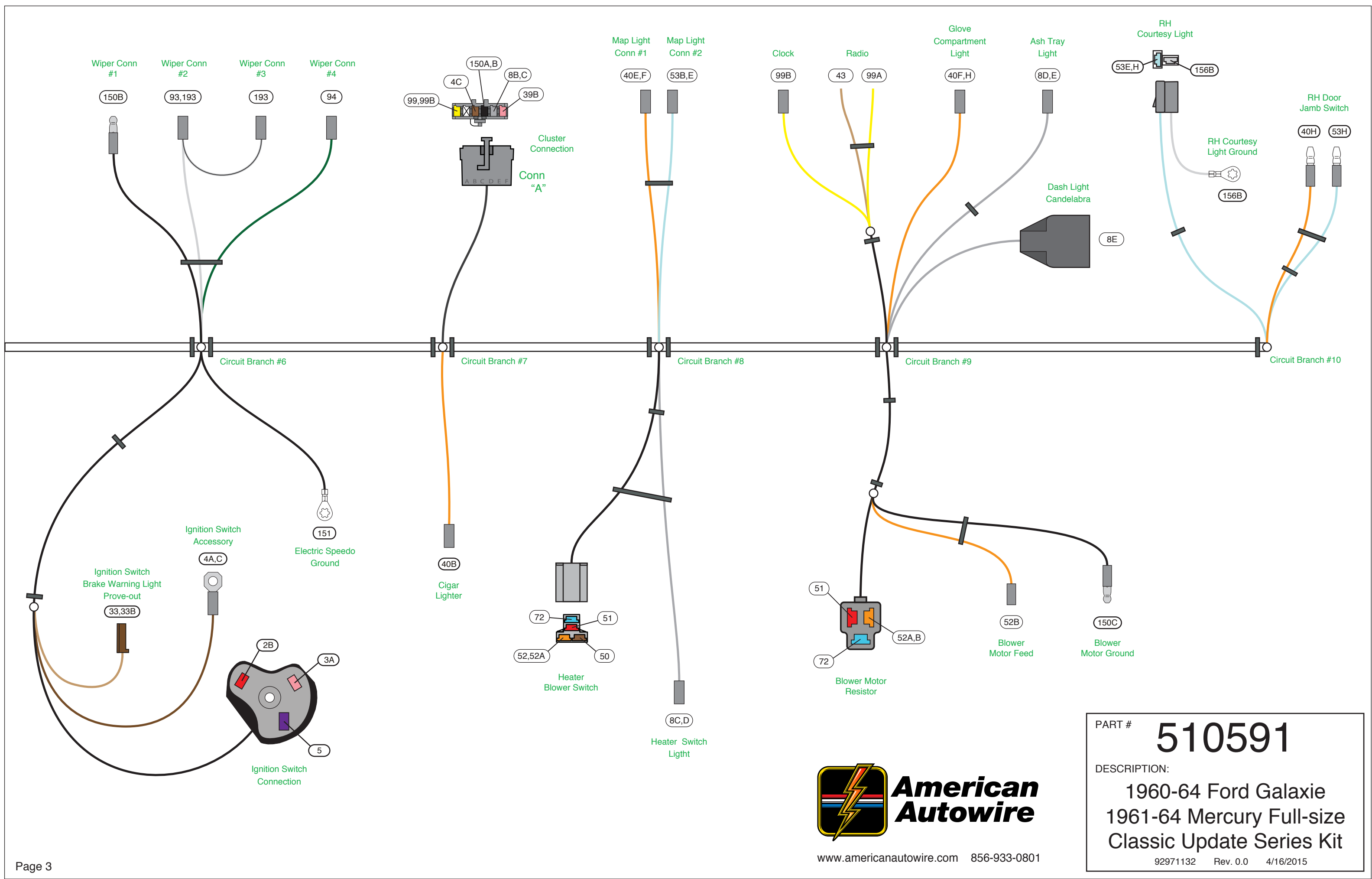

PART # **510591**

DESCRIPTION:
 1960-64 Ford Galaxie
 1961-64 Mercury Full-size
 Classic Update Series Kit

92971132 Rev. 0.0 4/16/2015

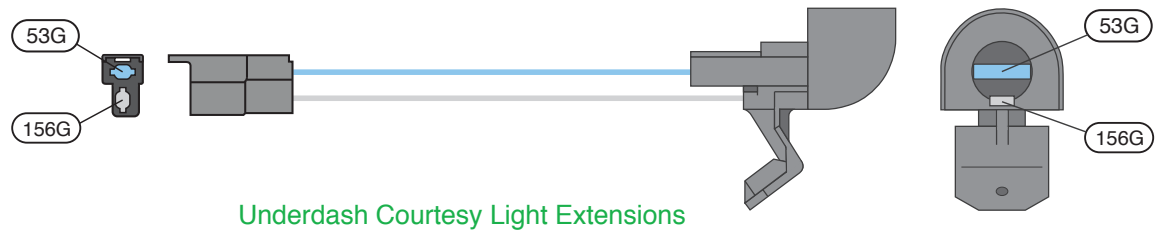

Underdash Courtesy Light Extensions

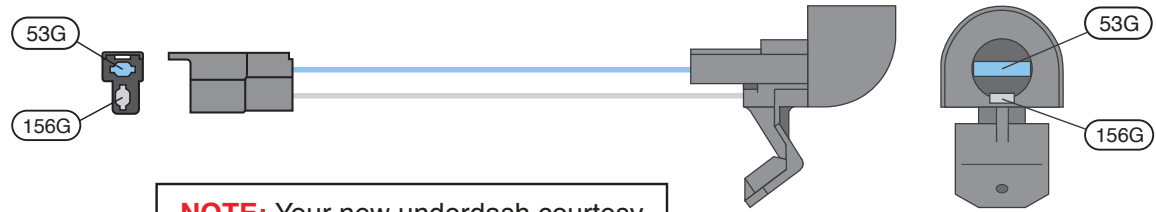

NOTE: Your new underdash courtesy light extensions, use # 631 bulbs (not included with this kit). They may be purchased at any auto parts store.



GM "SI" Alternator Exciter Wiring



Main Power Feed Fusible Link



Brake Pressure Differential Warning Switch Extension



Starter Solenoid Resistor Bypass Wiring



Alternator Feed Wiring

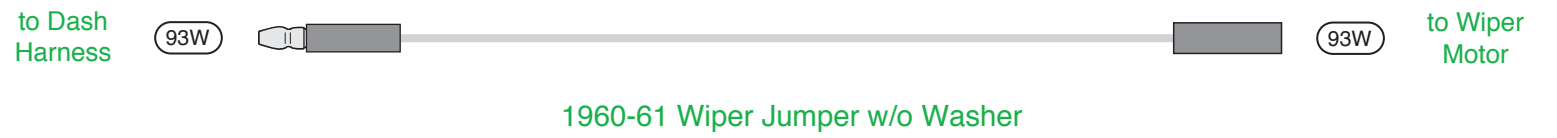

1960-61 Wiper Jumper w/o Washer

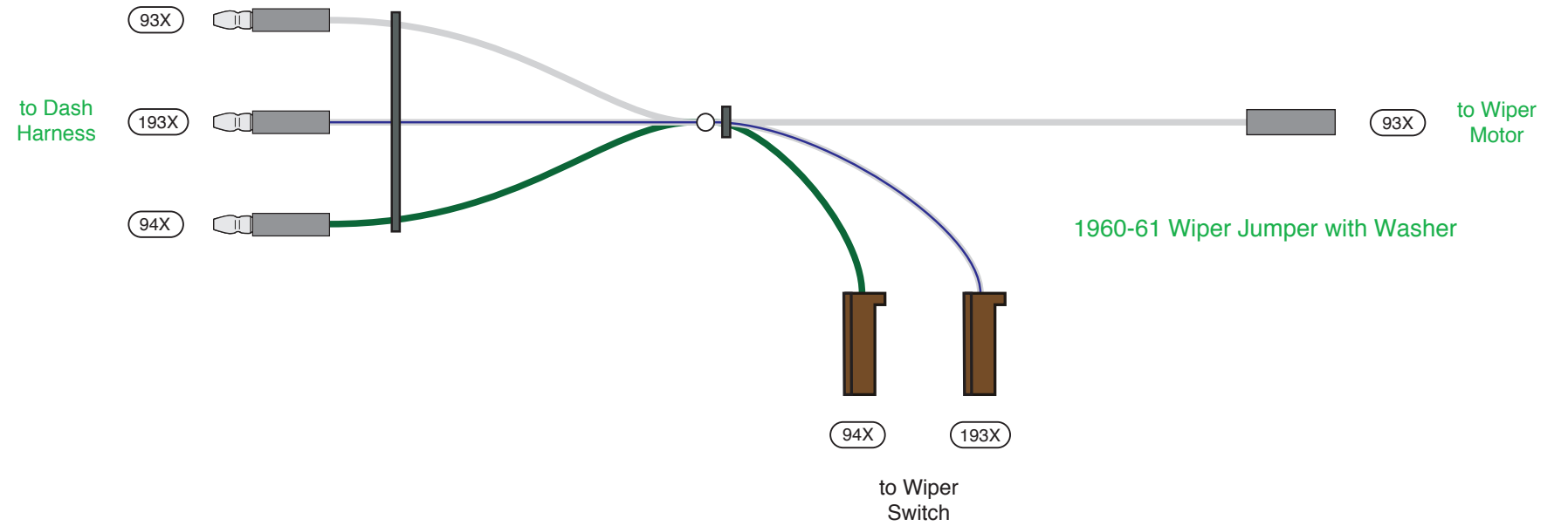

1960-61 Wiper Jumper with Washer

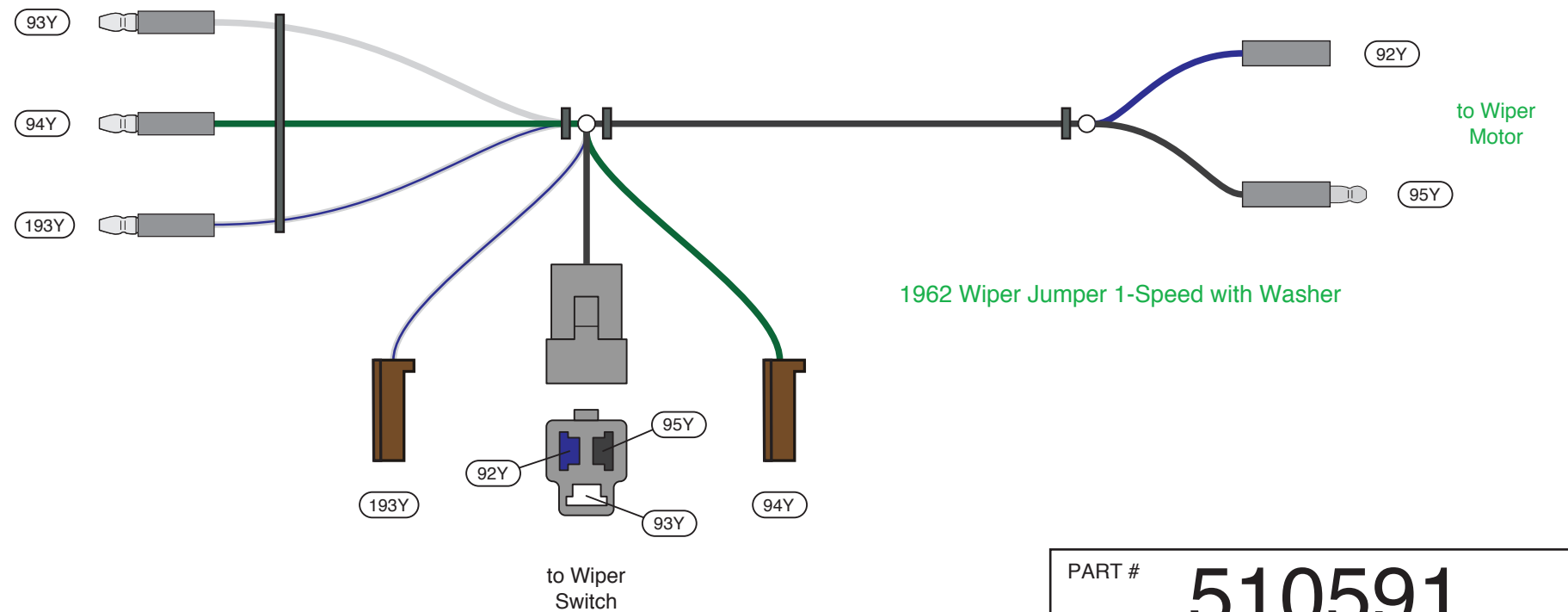

1962 Wiper Jumper 1-Speed with Washer



www.americanautowire.com 856-933-0801

PART # **510591**

DESCRIPTION:
1960-64 Ford Galaxie
1961-64 Mercury Full-size
Classic Update Series Kit

92971132 Rev. 0.0 4/16/2015

Prior to installing the Main Dash Harness, obtain the **Fuse and Flasher Kit 510557**. Plug all of the fuses in the Fuse Block (see page 18 for the location of the fuses). Install the Horn Relay to the Dash Harness 510592 (see circuit Branch #3, page 9 for the Horn Relay location).

Main Dash Harness Installation Instructions

Mount the Fuse Block to the Firewall as shown in the **Fuse Block Mounting Instructions 92971155**. Install a round grommet (item "F") found in **Parts Kit 510596** in each original rectangular Firewall Wiring pass-through hole located above the Fuse Block. Install two J-Clamps (item "S"), found in the **510596 Parts Kit**, to the Steering Column Support Bracket (see the "S" Clamp location photograph on this page). Use the Bolt, Nut and Washer (item "R") from the **510596 Parts Kit** to attach the J-Clamps. The Dash Harness routing will be similar to the original Instrument Panel Wiring Harness routing, except the Dash Harness will attach to the Steering Column Support Bracket instead of the Instrument Cluster. Now proceed to the Circuit Branch #1 instructions.

Circuit Branch #1 – LH Engine Compartment Connections

Route the Left Hand Engine Compartment wiring through the lower rectangular hole in the Firewall that already has grommet "F" installed. You may wish to remove the zip ties from the wiring when routing the wiring through the grommets.

Brake System **Note:** If you choose to upgrade the single Reservoir Brake System to an upgraded Brake System, we have provided a pigtail to connect to a new single post style Brake Pressure Differential Warning Switch (not provided in this kit), and have provided the wires in the Dash Harness for a Brake Warning Light.

Brake Pressure Differential Warning Switch Connection **Note:** there is a single wire pigtail assembly **Brake Pressure Differential Warning Switch Extension Harness (shown on page 4, circuit 33A, found in Bag G)** that will connect directly to your Brake Pressure Differential Warning Switch. This pigtail is designed to connect to a newer single post style Brake Pressure Differential Warning Switch. If you have a twin post Brake Warning Switch, you will need the original Ford twin post wire harness pigtail. Cut the two Ford purple wires about six inches back from your twin post Warning Switch connector, double them together, and splice them into the Brake Pressure Differential Warning Switch Extension Harness in place of the single post connector. Now plug this wire pigtail assembly onto the Brake Pressure Differential Warning Switch (see Figure A on page 16).

Wire	Wire Color	Printing	Description
33A	Tan	no printing	Brake Warning feed in the Brake Pressure Differential Warning Switch Extension Harness.

Brake Pressure Differential Warning Switch Extension Harness Connection Now that you have connected the single wire pigtail (**Brake Pressure Differential Warning Switch Extension Harness**) to the Brake Warning Switch in the previous step, route the tan wire (circuit 33) from the Dash Harness to this pigtail, cut to length, install terminal "B", and plug into connector "E" as shown on page 16 (both are found in kit 510596). Now connect to the **Brake Pressure Differential Warning Switch Extension Harness**.

Wire#	Wire Color	Printing	Description
33	Tan	BRAKE LIGHT/SWITCH	Brake Warning feed.

Aftermarket Electric Fan This circuit is provided to feed the trigger wire of your Electric Fan Relay (not provided with this kit). See the Electric Fan Manufacturers recommendations for the electrical hook up. **NOTE: This is a keyed hot feed.**

Wire#	Wire Color	Printing	Description
300	Orange	ELECTRIC FAN	12V Ignition feed to the trigger wire of the Electric Fan Relay.

LH FRONT LIGHTING

NOTE: The original factory Front Lighting wiring routed from the left side of the vehicle to the right side of the vehicle below the Radiator. This kit does not route any wiring across the front end of the vehicle. There are separate Left and Right wiring branches to the Front Park/Turn Signal Lights and HeadLights.

Park/Turn Signal – Light & Socket Assemblies **NOTE:** You will need to reuse the original Front Park/Turn Signal Light & Socket Assemblies, but will have to replace each 2-way bullet connector with a 2-way American Autowire (AAW) connector (see Figure A, on page 16 and Figure B, on page 17). Be sure that the Park/Turn Signal pigtail is routed and retained, per the original factory routing, before replacing the connectors. For both LH and RH Park/Turn Light & Socket Assemblies, remove the old 2-way molded bullet connectors, and install terminals "W" to each wire and install the wires in the 2-way connector "V" (all supplied in kit 510596) as shown in Figure A, on page 16 and Figure B, on page 17. The original Ford Left Front Turn wire is green/white and the Park Light wire is black/yellow. The original Ford Right Front Turn wire is white/blue and the Park Light wire is black/yellow.

Left Hand Park/Turn Light Connector Select the brown Park Light wire (circuit 9), route the wire to the 2-way connector "V" that was just added, cut to length, crimp on terminal "B", and install into connector "T" (see Figure A, on page 16). Be sure to align the AAW brown Park Light wire with the original Park Light wire.

Select the light blue Left Front Turn wire (circuit 14A), route this wire to the same connector "T" where wire 9 is located. Crimp on terminal "B", and install into connector "T" (see Figure A, on page 16). Now make the connection to the LH Park/Turn Light & Socket Assembly pigtail.

Wire#	Wire Color	Printing	Description
9	Brown	PARK LIGHTS	Park Light feed.
14A	Lt Blue	LEFT FRONT TURN	Left Front Turn Signal feed.

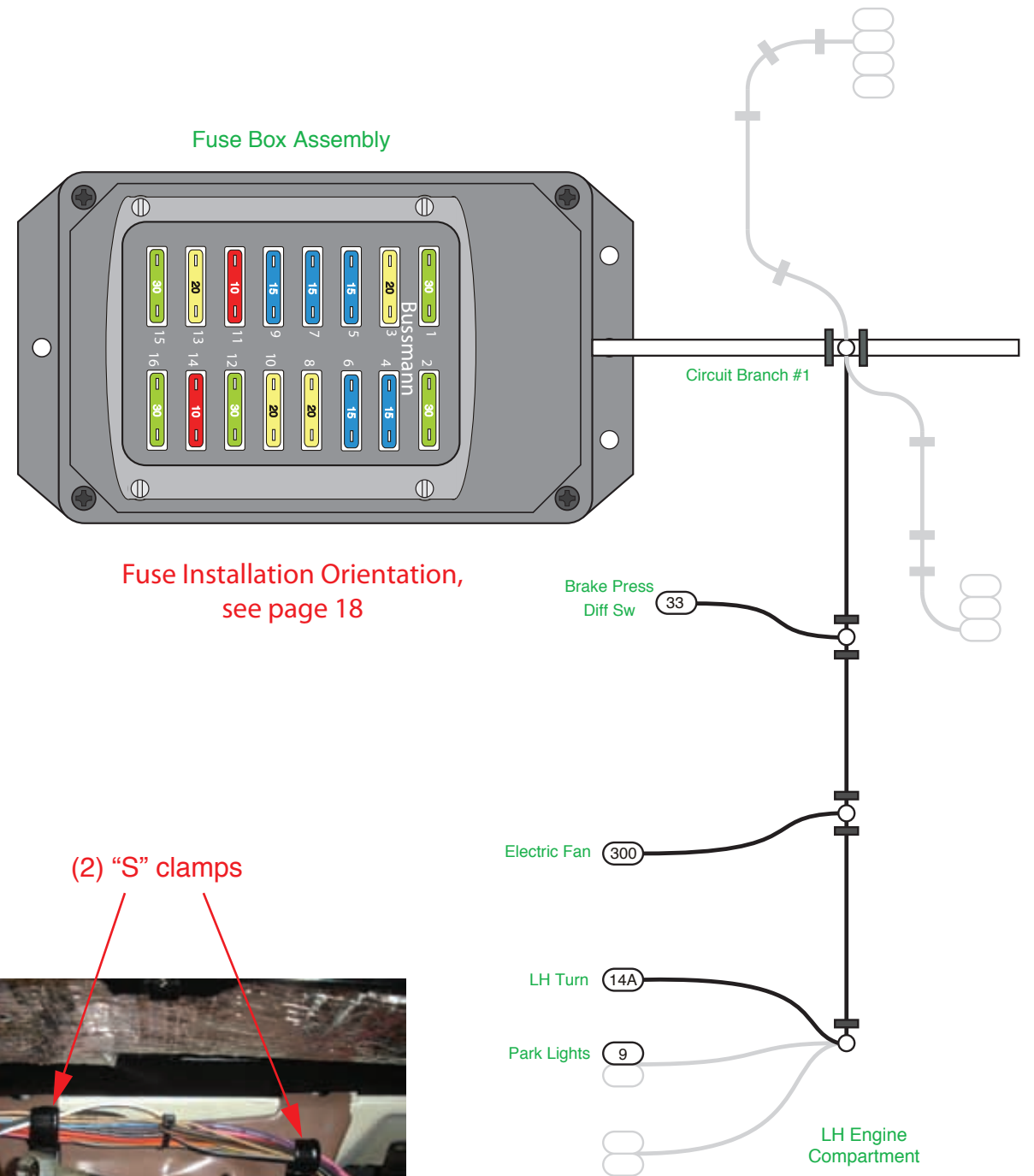

Fuse Installation Orientation, see page 18

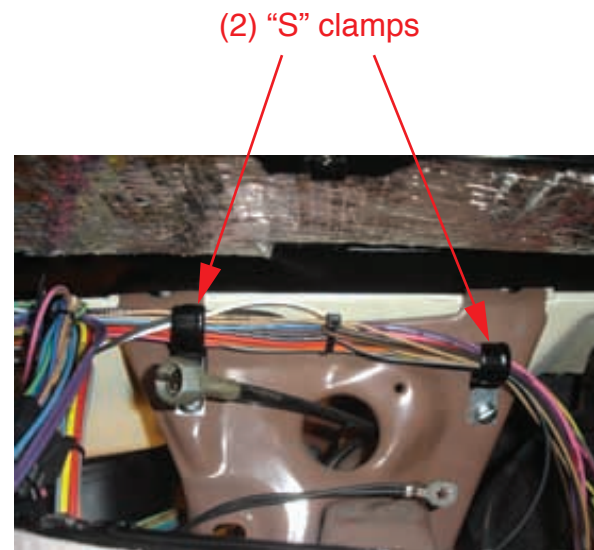

"S" clamp location photograph



www.americanautowire.com 856-933-0801

PART # **510591**

DESCRIPTION:
1960-64 Ford Galaxie
1961-64 Mercury Full-size
Classic Update Series Kit

92971132 Rev. 0.0 4/16/2015

LH and RH Headlight Extension Harnesses

Obtain the **Headlight Extension Harnesses 510595 (Bag N)** and connect to your LH and RH Headlights (see pages 16 and 17).

LH Headlights Select the light green Headlight High Beam wire (circuit 11A) and the tan Headlight Low Beam wire (circuit 12) and route them to the **Headlight Extension Harness**, cut to length, and crimp on a terminal "W" to each wire, and plug the two wires into connector "U". Be sure to align the light green wire with the light green wire of the **Headlight Extension Harness** and the tan wire with the tan wire. Now make the connection to the **Headlight Extension Harness**. Attach the ground ring terminal of the **Headlight Extension Harness** to a good Radiator Core Support ground.

Wire#	Wire Color	Printing	Description
11A	Lt Green	HEADLIGHT-HI BEAM	High Beam feed to the LH Headlight
12	Tan	HEADLIGHT-LOW BEAM	Low Beam feed to the LH Headlight.

Horn Connection Route the dark green Horn wire (circuit 29) to the LH Horn and cut to length, double with the wire that was just cut, crimp on terminal "C" and insert into connector "N" and attach to the LH Horn (see Figure A on page 16). Route the loose wire to the RH Horn and crimp on terminal "B" and insert into connector "N" and attach to the RH Horn. **All of the connectors and terminals will be found in kit 510596.**

Wire#	Wire Color	Printing	Description
29	Dark Green	HORN	Horn feed.

The Back-up and Neutral Safety Switches **Note: These wires are coiled up.** For both a Manual Transmission and an Automatic Transmission, route the light green Back-up Switch/Light wire (circuit 24) and the pink 12 Volt Ignition wire (circuit 39C) to the Back-up Light Switch and connect.

If you have a Manual Transmission, you will need to connect the purple Neutral Safety Switch wire (circuit 5) and the purple Starter Solenoid wire (circuit 6) together.

If you have an Automatic Transmission, route the purple Neutral Safety Switch wire (circuit 5) and the purple Starter Solenoid wire (circuit 6) to the Neutral Safety Switch and connect. A typical connection for the Neutral Safety/Back-up Switch can be found on page 16, Figure D.

Note: If circuit 5 and circuit 6 are not connected, your Starter Solenoid will not engage, and your Engine will not crank.

Wire#	Wire Color	Printing	Description
5	Purple	NEUTRAL SAFETY SWITCH	Start feed from the Ignition Switch to the Neutral Safety Switch or to circuit 6.
6	Purple	STARTER SOLENOID-S	Start circuit from the Neutral Safety switch or circuit 5 to the Starter Solenoid.
24	Lt Green	BACK UP LT SW	Feed from the Back-up Light switch to the Back-up Lights.
39C	Pink	12V IGNITION	12V feed to the Back-up Light Switch.

Aftermarket Electric Speedometer Sensor **Note: These wires are coiled up.** Connect these three wires to your Aftermarket Electric Speedometer Speed Sensor per the manufacturer's recommendations. **Note that wires 400 and 401 must remain twisted together.**

Wire#	Wire Color	Printing	Description
400	Yellow	VSS GROUND	Vehicle Speed Sensor Ground.
401	Purple	VSS SIGNAL	Vehicle Speed Sensor Signal.
402	Purple/White	VSS POWER	Vehicle Speed Sensor Power if using a 3 wire sender.

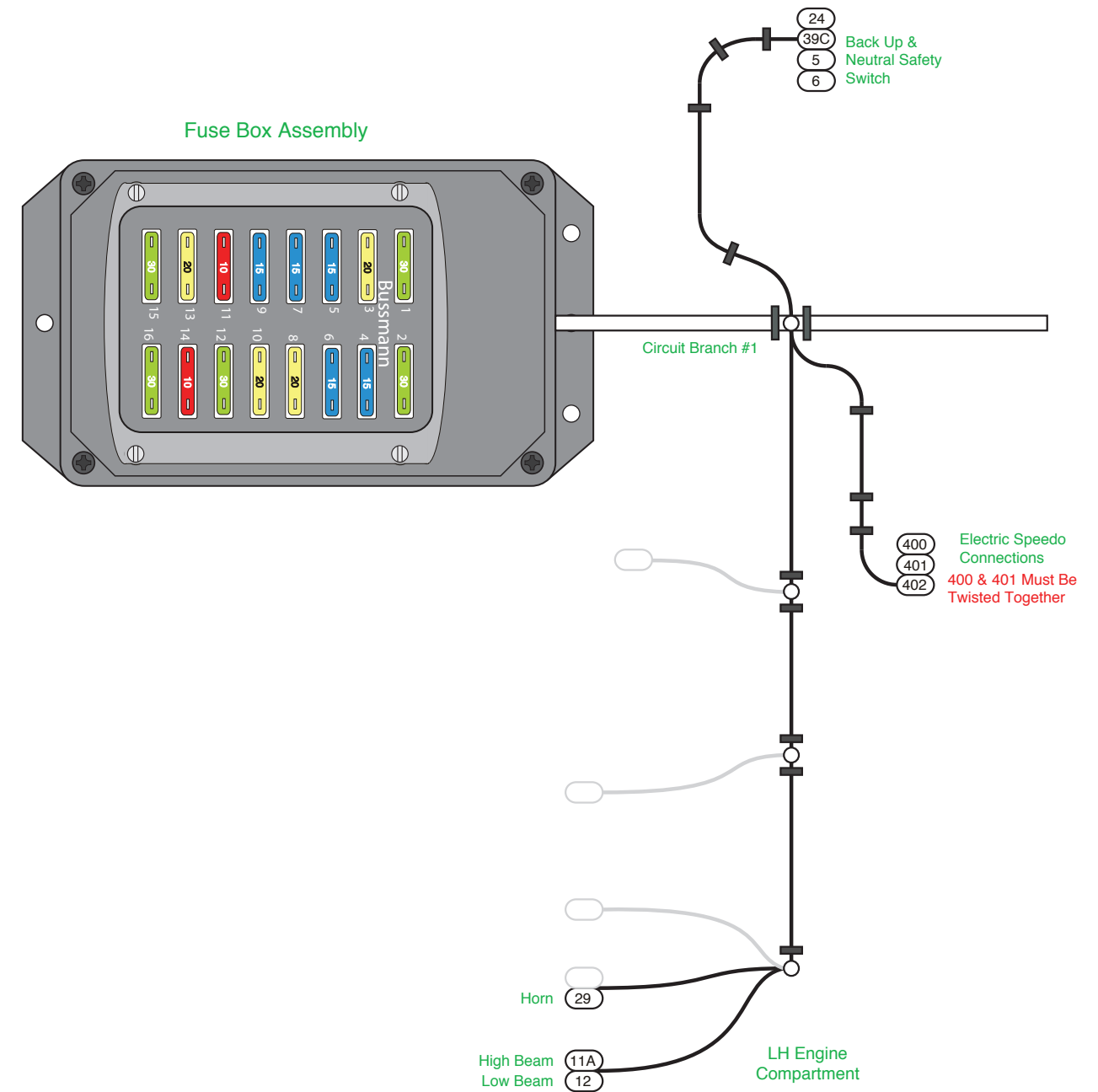

www.americanautowire.com 856-933-0801

PART # **510591**

DESCRIPTION:
1960-64 Ford Galaxie
1961-64 Mercury Full-size
Classic Update Series Kit

92971132 Rev. 0.0 4/16/2015

Circuit Branch #2 – Under Dash Connections

Rear Body Harness Connector This connector will plug to the **Rear Body Harness 510594 (Bag M)**. Specific connections are addressed in that kit. The Rear Body Harness will route across the Firewall and rearward along the Floor tunnel the same as the original Ford Body Harness routing. Be sure to attach the wiring in the original wiring clips.

Wire#	Wire Color	Printing	Description
9	Brown	PARK LIGHTS	Feed to the Front Park Lights.
9A	Brown	REAR RUNNING LIGHTS	Feed for the License Light and the Rear Running Lights.
17B	Light Blue	THIRD BRAKE LIGHT	Feed for an Aftermarket Third Brake Light.
18	Yellow	LEFT REAR TURN	Feed to the Left Rear Stop and Turn Light.
19	Dark Green	RIGHT REAR TURN	Feed to the Right Rear Stop and Turn Light.
24	Light Green	BACK UP LT SW	Feed from the Back-up Light switch to the Back-up Lights.
30	Tan	GAS GAUGE	Fuel Tank Sender.
40G	Orange	12V BATTERY-FUSED	12V Fused Battery feed for the Rear Door Courtesy Light Switches, the Trunk Light, or Aftermarket LED Rear Tail Lights.
53C, 53D	Light Blue	12V CTSY SW	12V Switched feed for the Dome Light, the Front Door Courtesy Lights, the Rear Door Courtesy Light Switches, or the C-Pillar Courtesy Lights.

Circuit Branch #2 – RH Engine Compartment Connections

Route the Right Hand Engine Compartment wiring through the upper rectangular hole in the Firewall that already has grommet "F" installed. You may wish to remove the zip ties from the wiring when routing the wiring through the grommets.

Stop Light Switch This Stop Light Switch is located on the Brake Master Cylinder. Route wires 17A and 40D to the switch. Cut to length, and install sleeve "D" on each wire (see Figure B on page 17). Crimp on terminal "X" and slide "D" over the terminal. Now connect to the switch, polarity doesn't matter. **Note: If you upgrade your Brake System, and the Stop Light Switch is now part of the Brake Pedal Assembly, these are the two circuits that should be connected to the Stop Light Switch.**

Wire#	Wire Color	Printing	Description
17A	White	BRAKE SW	Brake Light feed to the Turn Signal switch.
40D	Orange	BRAKE SW	This is the 12V feed from the Fuse Block.

Electric Choke The tan Electric Choke wire (circuit 39A) is the feed to the Electric Choke (if equipped). Route the 39A wire to the Electric Choke and connect. No connectors or terminals have been provided for this connection.

Wire#	Wire Color	Printing	Description
39A	Tan	ELECTRIC CHOKE	On carbureted vehicles, connect to the Electric Choke.

Ignition Feed This pink Ignition Feed wire (circuit 3B) is your 12V switched power source for the Distributor/Ignition Coil. This wire can be connected directly to the "Bat" terminal on a typical HEI Distributor, to a Ballast Resistor for a points type Distributor, or to be used as the ignition power source for an Aftermarket Ignition Module such as an MSD or a "Dura Spark" module. See the installation instructions for the type of Distributor you are using for specific connection requirements.

If you are using a GM style HEI Distributor, terminal "C" and connector "P" (see Parts Kit 510596) have been provided to make that connection (see Figure B on page 17 for some examples).

If you are using a Ballast Resistor, terminal "C" and connector "E" (see Parts Kit 510596) have been provided to make that connection (see Figure B on page 17 for some examples).

Wire#	Wire Color	Printing	Description
3B	Pink	IGNITION FEED	Switched 12V Ignition feed for the ignition.

Engine Sensors Route the dark blue wire (circuit 31) to the Oil Pressure Sending Unit and the dark green wire (circuit 35) to the Water Temperature Sending Unit, cut to length, install terminals "B" or "M" (install sleeve "J" first if using "M"). If you are using terminal "B", plug it into connector "N" (see Figure B on page 17). See Parts Kit 510596 for connectors and terminals.

Wire#	Wire Color	Printing	Description
31	Dark Blue	OIL PRESSURE SENDER	Oil Pressure Sender.
35	Dark Green	WATER TEMP SENDER	Hot Water Temperature Sender.

Tachometer **Note: This Kit will not support the use of an original factory tachometer (see the Warning Page).** However, the white Tachometer wire (circuit 121) can be connected directly to the Tachometer terminal on a typical HEI Distributor, to the negative side of the Ignition Coil, or to the Tachometer connection in an Aftermarket Ignition Module such as an MSD module.

If you are using a GM style HEI Distributor, terminal "B" and connector "Q" (see Parts Kit 510596) have been provided to make that connection (see Figure B on page 17).

Wire#	Wire Color	Printing	Description
121	White	COIL @ TACH	Tachometer feed wire.

Blower Motor (1960-61 vehicles) If you have a 1960-61 vehicle, the Blower Motor is located in the Engine Compartment. The orange Blower Motor feed wire (circuit 52) is included in the Circuit Branch #2 wiring. **Note: If you have a 1962-64 vehicle, the Blower Motor is located in the Passenger Compartment and a separate wire has been provided for that connection in Circuit Branch #9.** For the 1960-61 vehicles, route the orange wire to the Blower Motor, cut to length, install sleeve "D" and crimp on a female bullet terminal "X". Connect this orange wire to the orange wire of the Blower Motor. If the orange pigtail wire on the Blower Motor doesn't have a male bullet terminal, we have provided sleeve "J" and a small male bullet terminal "H" which can be added to the Blower Motor pigtail.

Wire#	Wire Color	Printing	Description
52	Orange	HEAT/AIR	Feed to the Blower Motor (1960-61 vehicles).

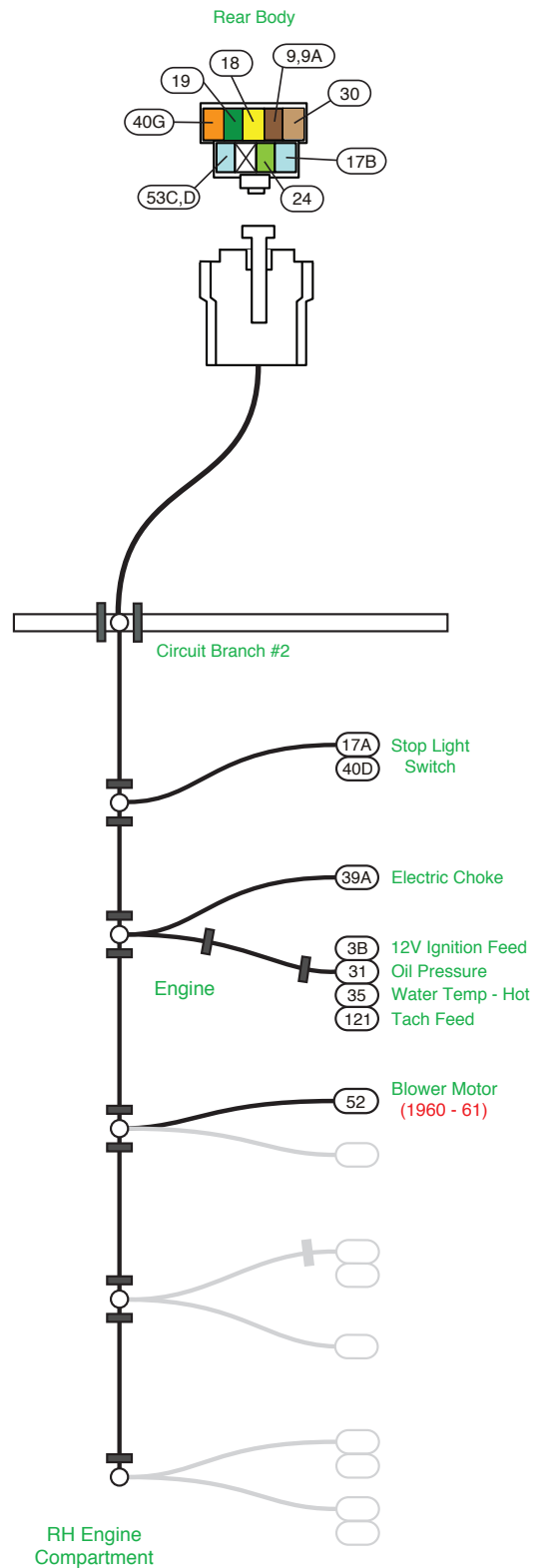

PART # **510591**

DESCRIPTION:
1960-64 Ford Galaxie
1961-64 Mercury Full-size
Classic Update Series Kit

92971132 Rev. 0.0 4/16/2015



Washer Pump Route the dark green Washer Pump feed wire (circuit 94) to the Washer Pump, cut to length, crimp on terminal "B" and insert into connector "E". Now connect to the Washer Pump.

Wire #	Wire Color	Printing	Description
94	Dark Green	no printing	Feed to the Washer Pump.

STARTER RELAY CONNECTIONS

Main Power Feed to the Fuse Block Route the red 12V Battery wire (circuit 2A) which is in the Dash Harness, to the Starter Relay (see Figure C on page 17) and cut to length, crimp on terminal "C" and insert into connector "E" (see parts kit 510596). Obtain the brown Main Power Feed Fusible Link (circuit 2J, shown on page 4 and included in Bag G) and plug into connector "E". Now attach the ring terminal end of the Main Power Feed Fusible Link to the battery terminal of the Starter Relay (see Figure C on page 17).

Wire#	Wire Color	Printing	Description
2A	Red	12V BATTERY	Main Power feed.
2J	Brown	Fusible Link	This is the circuit protection for the main power output.

Start Circuit Wire Route the purple Start wire (circuit 6) to the Starter Solenoid and cut to length, install sleeve "D" and crimp on terminal "K" (see parts kit 510596). Connect to the Starter Solenoid S stud (see Figure C on page 17).

Wire#	Wire Color	Printing	Description
6	Purple	STARTER SOLENOID-S	Start circuit.

Start Circuit Resistor Bypass Wire The yellow Starter Solenoid Resistor Bypass Wiring (circuit 7, shown on page 4 and included in Bag G) is provided if you are using an Ignition System with a Ballast Resistor (not included with this kit). Obtain the Starter Solenoid Resistor Bypass Wiring and attach the ring terminal to the "I" terminal on your Starter Solenoid (see Figure C on page 17). Route the other end of the yellow wire to the Ballast Resistor and cut to length. Obtain the cutoff section of the large pink "Ignition Feed" wire (circuit 3B from the Ignition Feed step) and double it with the yellow wire, crimp on terminal "C" and insert into connector "E". You can now connect to the Ballast Resistor. The other end of the large pink wire (circuit 3B) can be routed and connected to the (+) side of your Ignition Coil (see Figure B on page 17).

Wire#	Wire Color	Printing	Description
7	Yellow	STARTER SOLENOID-R	Resistor Bypass wire.

ALTERNATOR CONNECTIONS

Alternator Output Circuit Obtain the large red Alternator Feed Wiring with the blue fusible link Assembly (see Page 4) from Bag G, and connect the ring terminal end that has the blue fusible link to the Battery terminal on the Starter Solenoid (see Figure C on page 17). Route the other end to the Battery stud on the Alternator, slide on sleeve "D" (see parts kit 510596) and crimp on terminal "L".

Wire#	Wire Color	Printing	Description
2	Red	no printing	Alternator output wire.
2H	Light Blue	Fusible Link	This is the circuit protection for the Alternator output.

Alternator Exciter Wire The brown wire (circuit 4B) is the exciter wire for your Alternator/Voltage Regulator. If you are using a one wire Alternator, this wire will not be used and should be capped off as it is "hot" when the Ignition switch is in the "ON or ACC" position. If you are using an Alternator that requires an internal or external Voltage Regulator, this wire must be connected to the "switched or 12V ignition" terminal on your Voltage Regulator or Alternator according to the manufacturer's specifications for the type of Alternator/Voltage Regulator that is being used. An inline diode or resistor may be necessary to eliminate "run on" after being switched off. AAW recommends a Ford Gen 3 Internally Regulated or a one wire Alternator. If you are using a GM "SI" Alternator, obtain the GM "SI" Alternator Exciter Wiring Harness (see page 4, included in Bag G). Attach the ring terminal end of wire 2G to the Battery stud on the Alternator (see Figure C on page 17). Route the brown 4B wire in the Dash Harness to the 2-way connector, which is part of this same Exciter Wiring harness. Crimp on terminal "B" to wire 4B and insert into the open cavity of the 2-way connector. Now plug the 2-way connector into the "SI" Alternator.

Wire#	Wire Color	Printing	Description
2G	Red	no printing	Alternator Battery Stud wire in the GM "SI" Alternator Exciter Wiring Harness.
4B	Brown	ALTERNATOR IGN	Alternator Exciter wire.

RH FRONT LIGHTING

Right Hand Park/Turn Light Connector Select the brown Park Light wire (circuit 9B), route the wire to the 2-way connector "V" that was added previously to the Park/Turn Light & Socket pigtail, cut to length, crimp on terminal "B", and install into connector "T" (see page 17 Figure B). Be sure to align the AAW brown Park Light wire with the original Park Light wire.

Select the dark blue Right Front Turn wire (circuit 15A), route this wire to the same connector "T" where wire 9B is located. Crimp on terminal "B", and install into connector "T" (see page 17 Figure B). Now make the connection to the RH Park/Turn Light & Socket Assembly pigtail.

Wire#	Wire Color	Printing	Description
9B	Brown	PARK LIGHTS	Park Light feed.
15A	Dark Blue	RIGHT FRONT TURN	Right Front Turn Signal feed.

RH Headlights Select the light green Headlight High Beam wire (circuit 11C) and the tan Headlight Low Beam wire (circuit 12A) and route them to the Headlight Extension Harness, cut to length, and crimp on a terminal "W" to each wire, and plug the two wires into connector "U". Be sure to align the light green wire with the light green wire of the Headlight Extension Harness and the tan wire with the tan wire. Now make the connection to the Headlight Extension Harness. Attach the ground ring terminal of the Headlight Extension Harness to a good Radiator Core Support ground.

Wire#	Wire Color	Printing	Description
11C	Lt Green	HEADLIGHT-HI BEAM	High Beam feed to the RH Headlight
12A	Tan	HEADLIGHT-LOW BEAM	Low Beam feed to the RH Headlight.

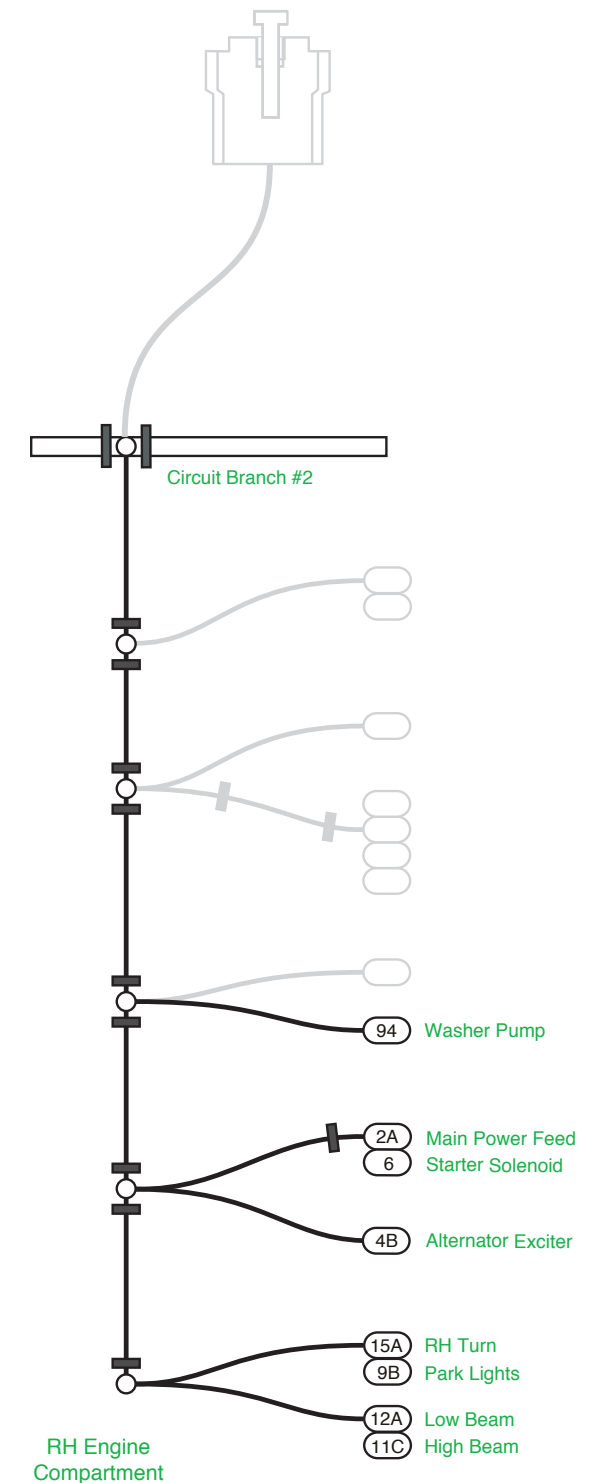

www.americanautowire.com 856-933-0801

PART # **510591**

DESCRIPTION:
1960-64 Ford Galaxie
1961-64 Mercury Full-size
Classic Update Series Kit

92971132 Rev. 0.0 4/16/2015

Circuit Branch #3 – Under Dash Connections

Accessory Connector Use the provided 6-way empty connector, which is attached to the 6-way Accessory Connector on the Dash Harness, and terminals “B” or “C” (see Parts Kit 510596) to add power leads (not provided) for the following systems:

Wire#	Wire Color	Printing	Fuse#	Fuse Block Cover	Fuse Rating	Description
100	Orange	no printing	7	Hazard	15A	Battery feed for Hazard or Audio Systems.
103	Tan	FUEL PUMP	10	Fuel Pump	20A	Ignition feed for an Electric Fuel Pump.
104	Orange	POWER SEATS	2	Pwr Seats	30A	Battery feed for Power Seats.
105	Red	POWER LOCKS	8	Pwr Locks	20A	Battery feed for Power Locks.
106	Pink	POWER WINDOWS	15	Pwr Window	30A	Accessory feed for Power Windows.
107	Orange	12V BATTERY FUSED	1	Bat-Spare	30A	Battery feed for options.

Horn Relay Connector If you haven't already, now plug the Horn Relay (found in the Fuse and Flasher Kit 510557) into this connector.

Wire#	Wire Color	Printing	Description
2C	Red	12V BATTERY	12V Battery feed to the Horn Relay.
28	Black	HORN RELAY GROUND	Relay ground circuit to the Steering Column.
29	Dark Green	HORN	Feed to the Horns.

Hazard Flasher Connector When the Flasher is plugged in, you will be able to supply power to a Turn Signal Switch, which is part of an Aftermarket (or a factory) Steering Column, with a Hazard Switch function. Plug the Flasher (part of the Fuse and Flasher Kit 510557) in, if so equipped.

Wire#	Wire Color	Printing	Description
27A	Brown	TURN SW – HAZARD	12V fused battery feed to the Hazard Flasher.
27B	Brown	TURN SW – HAZARD	Hazard Flasher feed to the Turn Signal Switch.

Circuit Branch #4 – Under Dash Connections

Dimmer Switch Route this wiring branch to the Dimmer Switch and connect. Plug this connector onto the Dimmer Switch 510042, and then attach the Dimmer Switch to the floor pan.

Wire#	Wire Color	Printing	Description
10	Yellow	DIMMER SWITCH FEED	Feed from the Headlight Switch
11A	Light Green	HEADLIGHT – HI BEAM	Feed to the LH Headlight High Beam.
11B	Light Green	HI BEAM INDICATOR LIGHT	Feed to the Hi beam Indicator Light in the Cluster.
11C	Light Green	HEADLIGHT – HI BEAM	Feed to the RH Headlight High Beam.
12	Tan	HEADLIGHT – LOW BEAM	Feed to the LH Headlight Low Beam.
12A	Tan	HEADLIGHT – LOW BEAM	Feed to the RH Headlight Low Beam.

Left Hand Door Jamb Switch Connection Route the two bullet terminals through the LH Door Jamb Switch hole from behind, and connect to the Door Jamb Switch (item “Y”, which is included in kit 510596). Polarity does not matter. Attach the Door Jamb Switch in the original location.

Wire#	Wire Color	Printing	Description
40A	Orange	12V BATTERY-FUSED	12V Fused Battery feed.
53D	Light Blue	12V CTSY SW	Feed to the LH Courtesy Light.

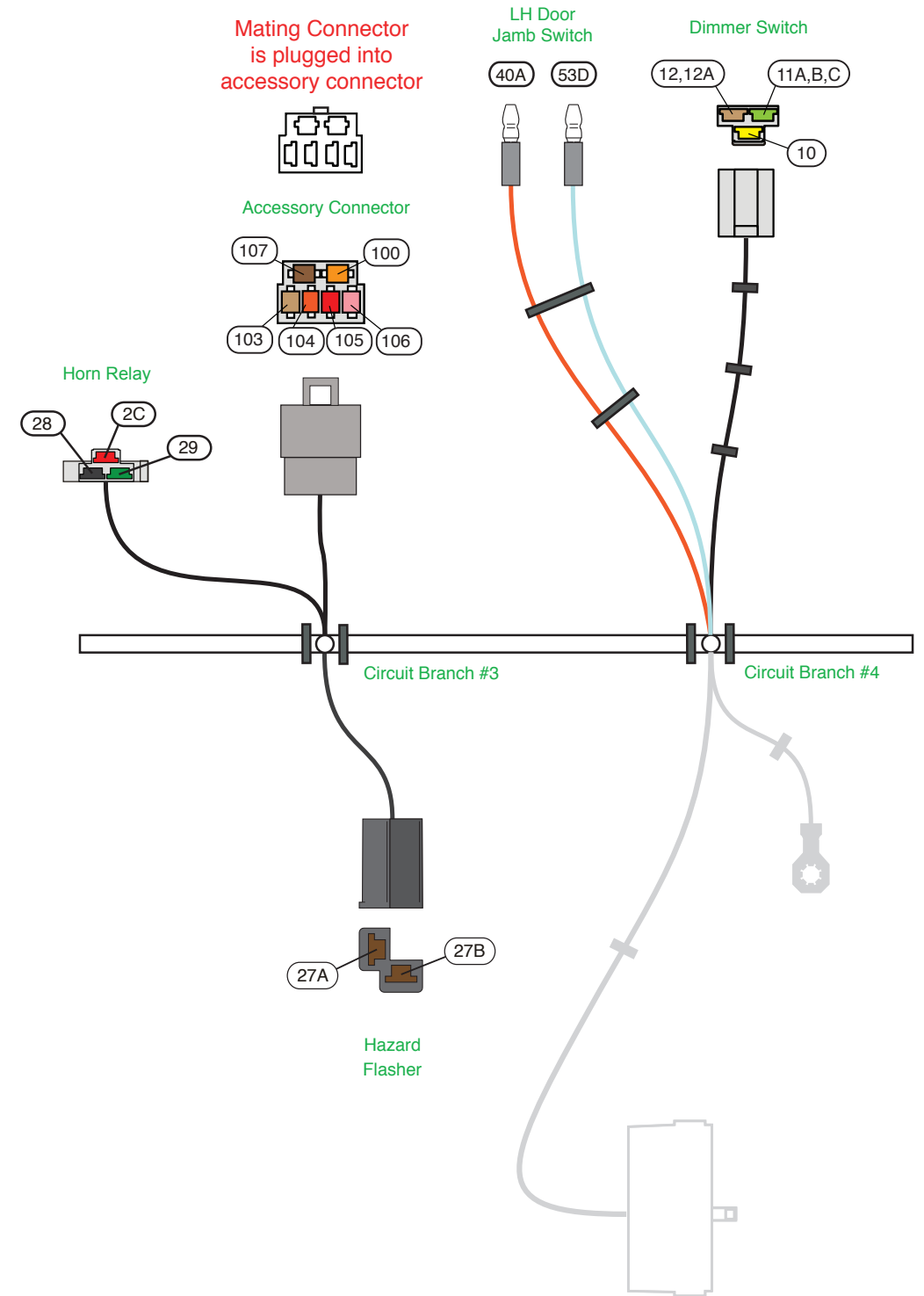

www.americanautowire.com 856-933-0801

PART # **510591**

DESCRIPTION:
 1960-64 Ford Galaxie
 1961-64 Mercury Full-size
 Classic Update Series Kit

92971132 Rev. 0.0 4/16/2015

Turn Signal Switch Connector Plug into the Steering Column Turn Signal Switch connector. If you are using a stock Ford Steering Column in your vehicle, refer to Diagram 'A' and 'Table A' on page 15 for the proper mating directions. This Dash Harness is designed to function with a GM style Turn Signal Switch. Our connector mates to a 3 7/8 inch long connector used on 1969-1974 GM, IDIDIT, and many other aftermarket Steering Columns. Starting from 1975 on up, the GM Switch changed, and began using a 4 1/4 inch long connector. That connector is from the same family and uses the same terminals. By using the supplied mating connector and terminals (located in the loose piece kit 92971137 inside Bag G), it is easy to adapt any Steering Column to this Dash Harness. The different functions, of the wires, in the Dash Harness Connector are as follows:

Wire#	Wire Color	Printing	Description
8A	Gray	DASH LIGHTS	Feed to the Gear Shift Indicator Light (PRNDL).
14A	Light Blue	LEFT FRONT TURN	Feed to the LH Front Turn Signal Light.
14B	Light Blue	LEFT DASH IND	Feed to the LH Turn Signal Indicator Light.
15A	Dark Blue	RIGHT FRONT TURN	Feed to the RH Front Turn Signal Light.
15B	Dark Blue	RIGHT DASH IND	Feed to the RH Turn Signal Indicator Light.
16B	Purple	TURN SWITCH FEED	Turn Signal Feed from the Turn Signal Flasher.
17A	White	BRAKE SW	Brake Switch feed to the Turn Signal Switch.
17B	Light Blue	THIRD BRAKE LIGHT	12V feed to the optional Third Brake Light.
18	Yellow	LEFT REAR TURN	Feed to the LH Rear Turn Signal Light.
19	Dark Green	RIGHT REAR TURN	Feed to the RH Rear Turn Signal Light.
27B	Brown	TURN SW – HAZARD	Hazard feed to the Turn Signal Switch from the Hazard Flasher for a Steering Column with the Hazard function.
28	Black	HORN RELAY GROUND	Horn Relay ground to the Horn Switch.

Ground Lead Attach this wire to a good body ground. **NOTE: Do not attach this ring terminal with the ground wire (circuit 151) in Circuit Branch #6.**

Wire#	Wire Color	Printing	Description
150A	Black	GROUND	Cluster Ground.
150C	Black	GROUND	Blower Motor Ground.

Circuit Branch #5 – Under Dash Connections

Instrument Cluster Connections These connections will plug into the Instrument Cluster Kit 510593 (Bag H). Instructions are included in that kit for the connections to the Instrument Cluster.

Cluster Connector "B"

Wire#	Wire Color	Printing	Description
11B	Light Green	HI BEAM INDICATOR LIGHT	Feed to the High Beam Indicator Light.
14B	Light Blue	LEFT DASH IND	Feed for the Left Turn Signal Indicator Light.
15B	Dark Blue	RIGHT DASH IND	Feed for the Right Turn Signal Indicator Light.
30	Tan	GAS GAUGE	Fuel Gauge Signal from the Fuel Tank Sender.
31	Dark Blue	OIL PRESSURE SENDER	Oil Pressure Sender signal from the Engine.
33B	Tan	BRAKE LIGHT/SWITCH	Brake Warning Light feed for an upgraded Brake System.
35	Dark Green	WATER TEMP SENDER	Water Temperature Sender signal from the Engine.
121	White	COIL -> TACH	Feed for an Aftermarket Tachometer (see the Warning Sheet).

Cluster Connector "C" This connector contains the circuits for an Aftermarket Electric Speedometer. **Wires "400" and "401" must remain twisted together.**

Wire#	Wire Color	Printing	Description
139	Pink/White	SPEEDO POWER	Fused 12V feed for the Electric Speedometer.
151	Black/White	SPEEDO GROUND	Electric Speedometer ground.
400	Yellow	VSS GROUND	Vehicle Speed Sensor ground.
401	Purple	VSS SIGNAL	Vehicle Speed Sensor signal.
402	Purple/White	VSS POWER	Vehicle Speed Sensor power.

Left Hand Courtesy Light Connector Plug this connector into one Under Dash Courtesy Light Wiring Harness (see page 4, obtain from Bag G) and attach to the lower Instrument Panel. The Courtesy Light Socket requires a #631 Bulb (not included in this kit).

Wire#	Wire Color	Printing	Description
53A, 53C	Light Blue	12V CTSY SW	12V Switched feed to the Left Hand Courtesy Light.
156A	White	CTSY GROUND	LH Courtesy Light ground. Attach this ring terminal to a good ground.

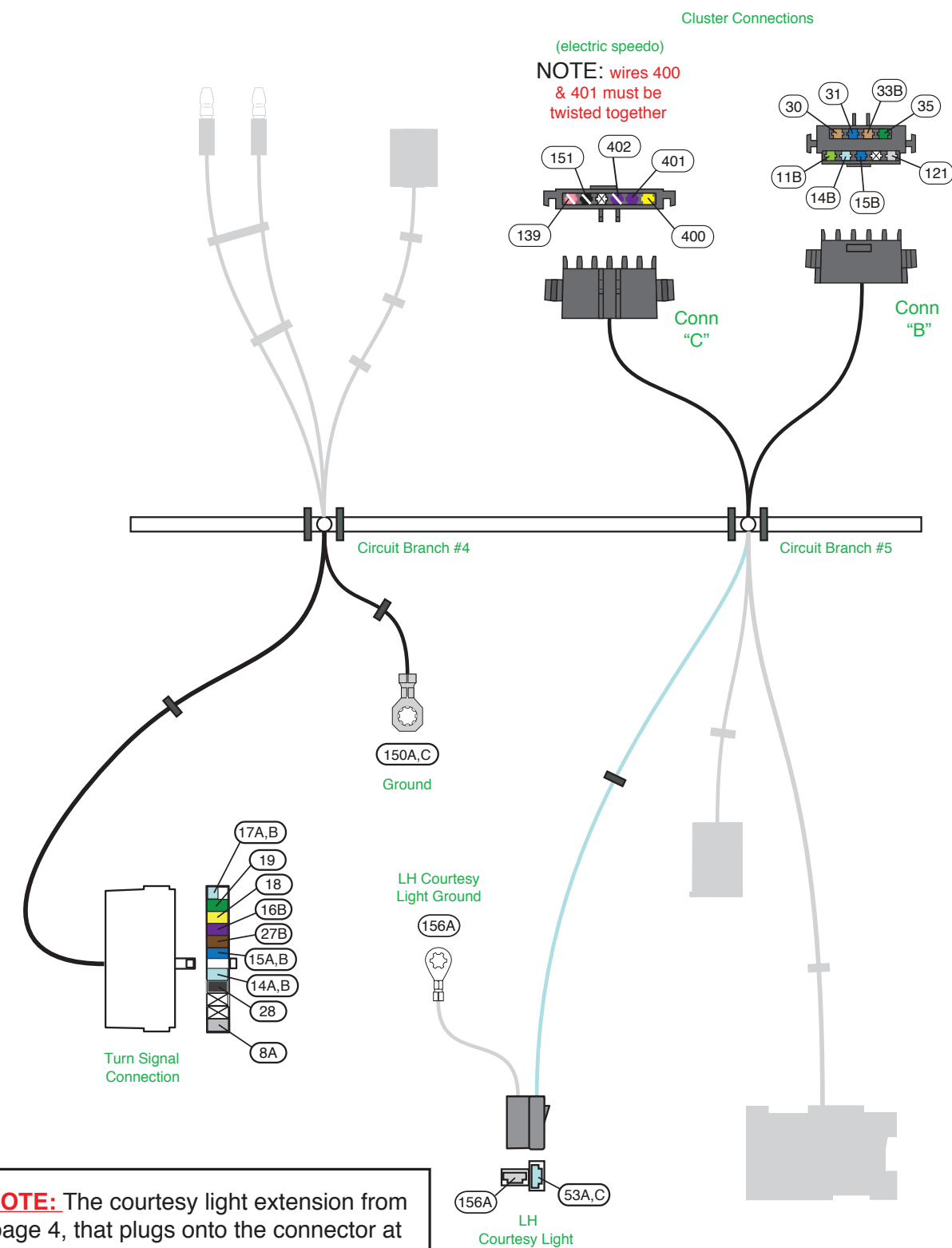

NOTE: The courtesy light extension from page 4, that plugs onto the connector at branch 5 on this page, uses a # 631 bulb (not included with this kit). They may be purchased at any auto parts store.



www.americanautowire.com 856-933-0801

PART # **510591**

DESCRIPTION:
1960-64 Ford Galaxie
1961-64 Mercury Full-size
Classic Update Series Kit

92971132 Rev. 0.0 4/16/2015

Turn Signal Flasher Connector This is the connector for the Turn Signal Flasher. Plug the Turn Signal Flasher (part of the Fuse and Flasher Kit 510557) into this connector. After the Flasher is connected, you can place it in the Flasher Holder on the back of the Instrument Cluster.

Wire #	Wire Color	Printing	Description
16A	Purple	TURN SWITCH FEED	12V fused ignition feed to the Turn Signal Flasher.
16B	Purple	TURN SWITCH FEED	Turn Signal Flasher feed to the Turn Signal Switch.

Headlight Switch Connector Plug this connector to the Headlight Switch 510264.

Wire#	Wire Color	Printing	Description
2D	Red	12V BATTERY	Un-fused 12V Battery feed from the Fuse Block.
8A	Gray	DASH LIGHTS	Dash Light feed to the Turn Signal Switch.
8B	Gray	DASH LIGHTS	Dash Light feed to the Cluster.
9A	Brown	REAR RUNNING LIGHTS	Feed to the Rear Tail Lights and License Light.
9B	Brown	PARK LIGHTS	Feed to the Front Park Lights.
10	Yellow	DIMMER SW FEED	Feed to the Dimmer Switch for the Headlights.
40C	Orange	12V BATTERY – FUSED	Fused 12V Battery feed from the Fuse Block.
40E	Orange	12V BATTERY – FUSED	Fused 12V Battery feed to the Map Light.
53A	Light Blue	12V CTSY SW	12V Switched feed to the LH Courtesy Light.
53B	Light Blue	12V CTSY SW	12V Switched feed to the Map Light.

Circuit Branch #6 – Under Dash Connections

Note: Circuit Branch #6, should be located in the center of the Steering Column Support Bracket, between the two J Clamps.

Wiper System Connections These connectors will connect to the various Wiper System Jumper Harnesses depending on model year of the vehicle. The jumpers are shown on page 4, and are included in Bag G. See page 18 for some photographs of the various connections.

For the 1960-61 vehicles without a Washer Pump, connect the Wiper Connector #2 (with circuits 93 and 193) in the Dash Harness, to the 1960-61 Wiper Jumper w/o Washer (with circuit 93W). Connect the other end of the Jumper Harness to the black Wiper Motor wire. You will not use Wiper Connectors #1, #3, and #4 in the Dash Harness.

For the 1960-61 vehicles with a Washer Pump, connect Wiper Connectors #2, #3, and #4 in the Dash Harness to the mating connectors in the 1960-61 Wiper Jumper with Washer. Be sure to match the wire colors. You will not use Wiper Connector #1 in the Dash Harness. Connect the other end of the Jumper Harness, to the black Wiper Motor wire.

For the 1962 vehicles with a 1-speed Wiper System, connect Wiper Connectors #2, #3, and #4 in the Dash Harness to the mating connectors in the 1962 Wiper Jumper 1-Speed with Washer. Be sure to match the wire colors. If you do not have a Washer Pump, you will not use Connectors #3 and #4. Connect the other end of the Jumper Harness to the Wiper Motor wires (blue to blue and black to black).

For the 1962 vehicles with a 2-speed wiper system, and all 1963 and 1964 vehicles, you will have to connect the original factory Wiper Harness to Wiper Connectors #1, #2, #3, and #4 in the Dash Harness. Connect the American Autowire (AAW) wires, to the original Ford Wiper Jumper Harnesss wires, as follows:

All 1962 with a 2-speed Wiper System and all 1963 Vehicles.

AAW Wire Color	Ford Wiper Harness Wire Color	Description
White	Yellow/Black	12V Accessory Feed.
Green	Green/Black	Washer Pump Feed.
Black	Black	Ground.
White/Blue	none	12V Feed to Wiper Switch for the Washer Pump.

All 1964 Vehicles.

AAW Wire Color	Ford Wiper Harness Wire Color	Description
White	Orange/White	12V Accessory Feed.
Green	Black/White	Washer Pump Feed.
Black	Black and/or White	Ground.
White/Blue	Tan	12V Feed to Wiper Switch for the Washer Pump.

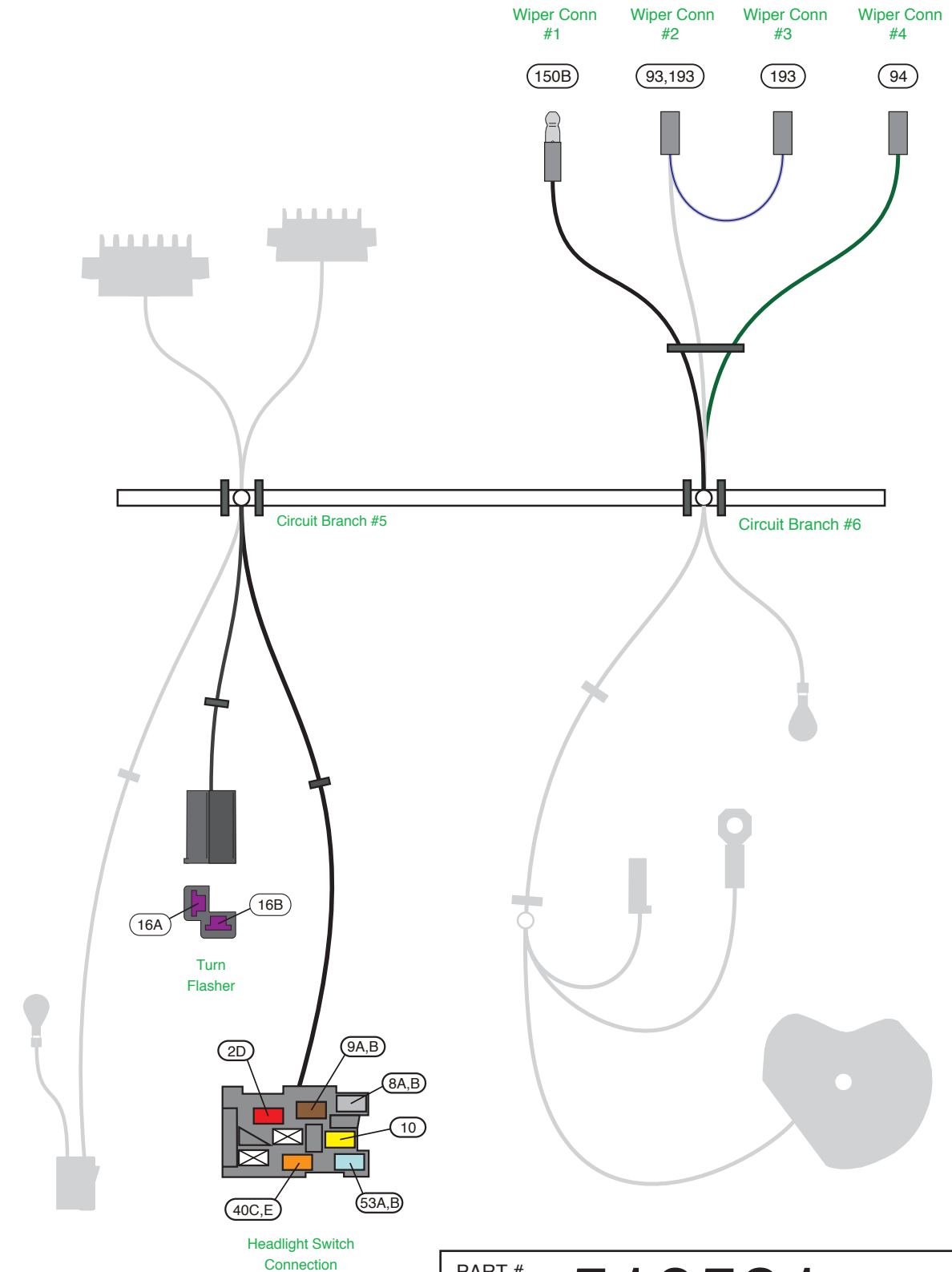

www.americanautowire.com 856-933-0801

PART # **510591**

DESCRIPTION:
1960-64 Ford Galaxie
1961-64 Mercury Full-size
Classic Update Series Kit

92971132 Rev. 0.0 4/16/2015

Wiper Jumpers

Wire#	Wire Color	Printing	Description
93W	White	WIPER FEED	Wiper feed for a 1960-61 vehicle without a Washer.
93X	White	WIPER FEED	Wiper feed for a 1960-61 vehicle with a Washer.
93Y	White	WIPER FEED	Wiper feed for a 1962 vehicle with a 1-speed Wiper System.
94X	Dark Green	no printing	Washer Pump feed for a 1960-61 vehicle.
94Y	Dark Green	no printing	Washer Pump feed for a 1962 vehicle.
193X	White/Dark Blue	no printing	12V feed to the Wiper Switch for the Washer Pump (1960-61 vehicles).
193Y	White/Dark Blue	no printing	12V feed to the Wiper Switch for the Washer Pump (1962 vehicles).

Wiper Connectors #1, #2, #3, and #4 in the Dash Harness.

Wire#	Wire Color	Printing	Description
93	White	WIPER FEED	Fused Wiper/Washer feed from the Fuse Block.
94	Dark Green	no printing	Feed to the Washer Pump.
150B	Black	GROUND	Ground for the 1963-64 Wiper Systems.
193	White/Dark Blue	no printing	Fused Washer feed from the Fuse Block.

Ignition Switch Connector Plug this connector to the Ignition Switch 510128. Use extra care when routing the wires away from the Ignition Switch. The Steering Column Support Bracket may be in close proximity to the wires and should be avoided.

Wire#	Wire Color	Printing	Description
2B	Red	12V BATTERY	12V Un-fused Battery feed from the Fuse Block.
3A	Pink	IGNITION FEED	Ignition feed to the Fuse Block.
5	Purple	NEUTRAL SAFETY SWITCH	Start feed to the Neutral Safety Switch or to the purple Starter Solenoid wire (circuit 6).

Ignition Switch Accessory Ring Terminal Attach this ring terminal to the Ignition Switch after the Ignition Switch Connector is plugged in. Use the nut to securely fasten the ring terminal to the Ignition Switch threaded stud. **Note: Do not over tighten.**

Wire#	Wire Color	Printing	Description
4A	Brown	IGNITION SW ACCY	12V Accessory feed to the Fuse Block.
4C	Brown	no printing	12V Accessory feed to the Cluster.

Ignition Switch Brake Warning Light Prove-out Connector If you have a vehicle with an upgraded Brake System, connect this to the Ignition Switch after the Ignition Switch Accessory Ring Terminal is attached. This connector plugs onto the blade terminal which is located on the side of the Ignition Switch. This wire provides the bulb check ground for the Brake Warning Light circuit when the Ignition Switch is in the "Start" position.

Wire#	Wire Color	Printing	Description
33, 33B	Tan	BRAKE LIGHT/SWITCH	Brake Warning Light Bulb Check during Crank.

Aftermarket Electric Speedometer Ground Attach this wire to a good ground. **NOTE: Do not attach this ring terminal with any other ground wires; it should be attached to ground all by itself.**

Wire#	Wire Color	Printing	Description
151	Black/White	SPEEDO GROUND	Ground for an Aftermarket Electric Speedometer.

Circuit Branch #7 – Under Dash Connections

Cluster Connector "A"

Wire#	Wire Color	Printing	Description
4C	Brown	no printing	Cluster 12V Accessory feed.
8B	Gray	DASH LIGHTS	Headlight Switch feed for the Cluster Illumination Lights.
8C	Gray	DASH LIGHTS	Dash Light feed to the Heater Switch Light.
39B	Pink	12V IGNITION	Fused 12V Ignition feed to the Cluster.
99	Yellow	CLOCK BAT	Battery feed to the Clock for the 1960-62 vehicles.
99B	Yellow	CLOCK BAT	Battery feed to the Clock for the 1963-64 vehicles.
150A, 150B	Black	GROUND	Cluster ground.

Cigar Lighter Connector Plug this connector onto the Cigar Lighter.

Wire#	Wire Color	Printing	Description
40B	Orange	no printing	Fused 12V Battery feed to the Cigar Lighter.

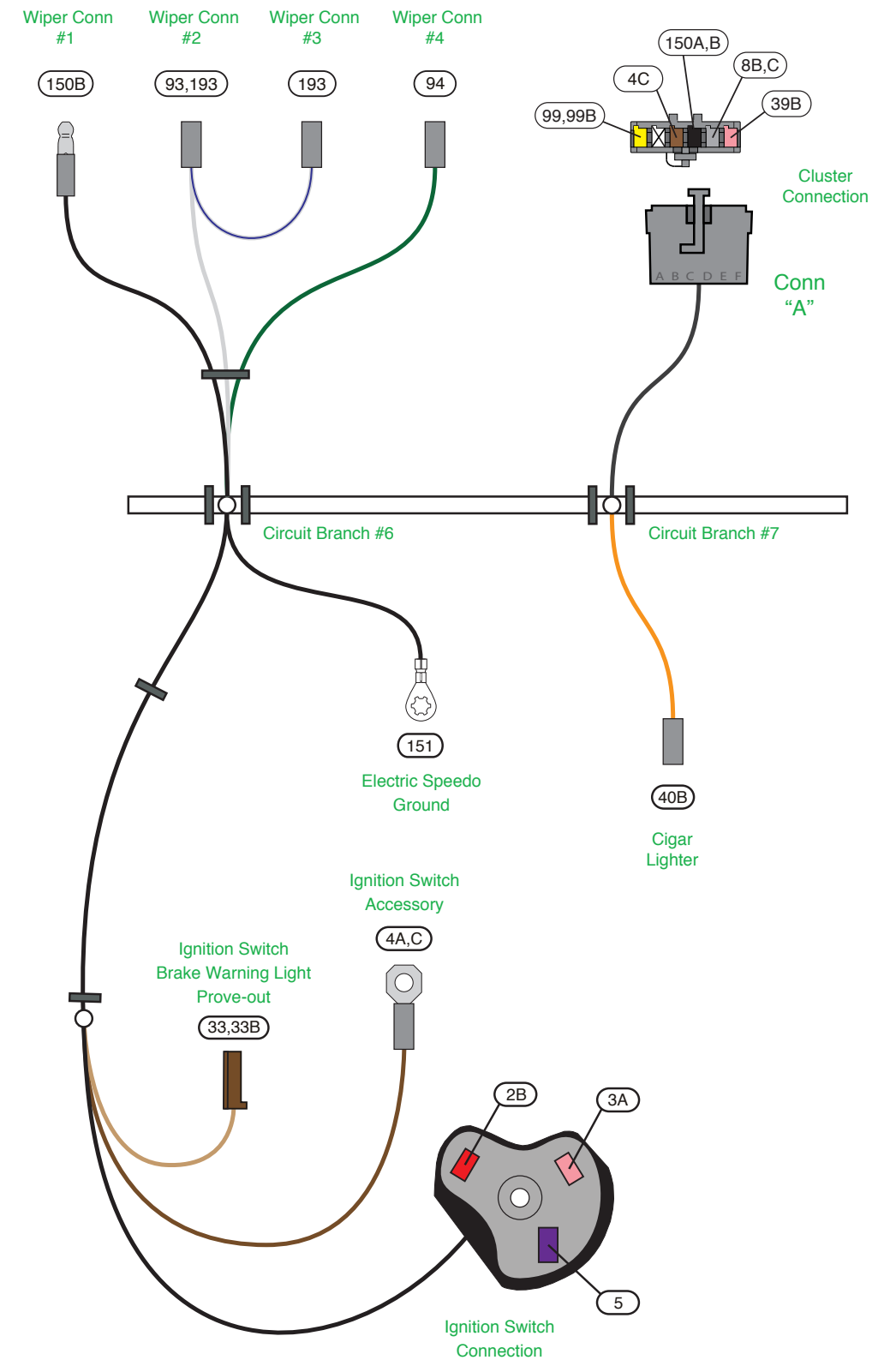

www.americanautowire.com 856-933-0801

PART # **510591**

DESCRIPTION:
 1960-64 Ford Galaxie
 1961-64 Mercury Full-size
 Classic Update Series Kit

92971132 Rev. 0.0 4/16/2015

Circuit Branch #8 – Under Dash Connections

Map Light Connectors

Map Light Connector #1 This connector contains the Battery feed for the optional Map Light. It mates to the green/yellow stripe wire on the Map Light.

Wire#	Wire Color	Printing	Description
40E, 40F	Orange	12V BATTERY - FUSED	Fused Battery feed for the Map Light.

Map Light Connector #2 This connector contains the Switched Courtesy Light Feed for the optional Map Light. It mates to the black/blue stripe wire on the Map Light.

Wire#	Wire Color	Printing	Description
53B, 53E	Light Blue	12V CTSY SW	12V Switched feed for the Map Light.

Heater Blower Switch Connector Connect this 4-way connector to the Heater Blower Switch. **NOTE: The other end of the 52 wire is needed for the 1960-61 vehicles only, which have the Blower Motor in the Engine Compartment (see Circuit Branch #2). This 52 wire is not used on the 1962-64 vehicles and should be capped off.**

Wire#	Wire Color	Printing	Description
50	Brown	HEATER/AC FEED	Fused 12V Blower Motor Switch feed. This wire should be used, as the 12V power feed for an Aftermarket Heater A/C System.
51	Red	no printing	Blower Motor Low Speed.
52	Orange	HEAT/AIR	Blower Motor feed (1960-61 vehicles).
52A	Orange	no printing	Blower Motor High Speed.
72	Light Blue	no printing	Blower Motor Medium Speed.

Heater Switch Light Connect to the Heater Switch Light.

Wire#	Wire Color	Printing	Description
8C, 8D	Gray	DASH LIGHTS	Feed for the Heater Switch Illumination Light.

Circuit Branch #9 – Under Dash Connections

Dash Light Candelabra Connect the Radio Illumination Light, the Clock Light(s), the Compass Light, the 1963 Mercury Ignition Switch Illumination Light, or any other option that requires a Dash Light feed to this Candelabra connector. **NOTE: If needed, extra (large) male bullet terminals "A" and sleeves "D" have been provided to replace your original terminals (all supplied in kit 510596).**

Wire#	Wire Color	Printing	Description
8E	Gray	DASH LIGHTS	Various Dash Light feeds.

Ash Tray Light Connector Plug this connector to your Ash Tray Illumination Light.

Wire#	Wire Color	Printing	Description
8D, 8E	Gray	DASH LIGHTS	Feed to the Ash Tray Illumination Light.

Glove Compartment Light Connector Plug this connector to your Glove Compartment Light.

Wire#	Wire Color	Printing	Description
40F, 40H	Orange	12V BATTERY – FUSED	Feed to the Glove Compartment Light.

Radio These circuits are provided for your Radio.

Wire#	Wire Color	Printing	Description
43	Tan	RADIO	12V Fused Accessory feed for the Radio "On/Off" power.
99A	Yellow	RADIO BAT	12V Fused Battery feed for the Radio Memory.

Clock Connector This connector is the Battery feed for your optional Clock (1963-64 vehicles). For the (1960-62 vehicles), the Clock is in the Instrument Cluster and the Battery feed connector is in the Instrument Cluster Kit. **NOTE: the Illumination Light Socket(s) and wiring (circuit 8, DASH LIGHTS) for the Clock (for all vehicles), are included in the Instrument Cluster Kit.**

Wire#	Wire Color	Printing	Description
99B	Yellow	CLOCK BAT	Fused Battery feed to the Clock (1963-64 vehicles).

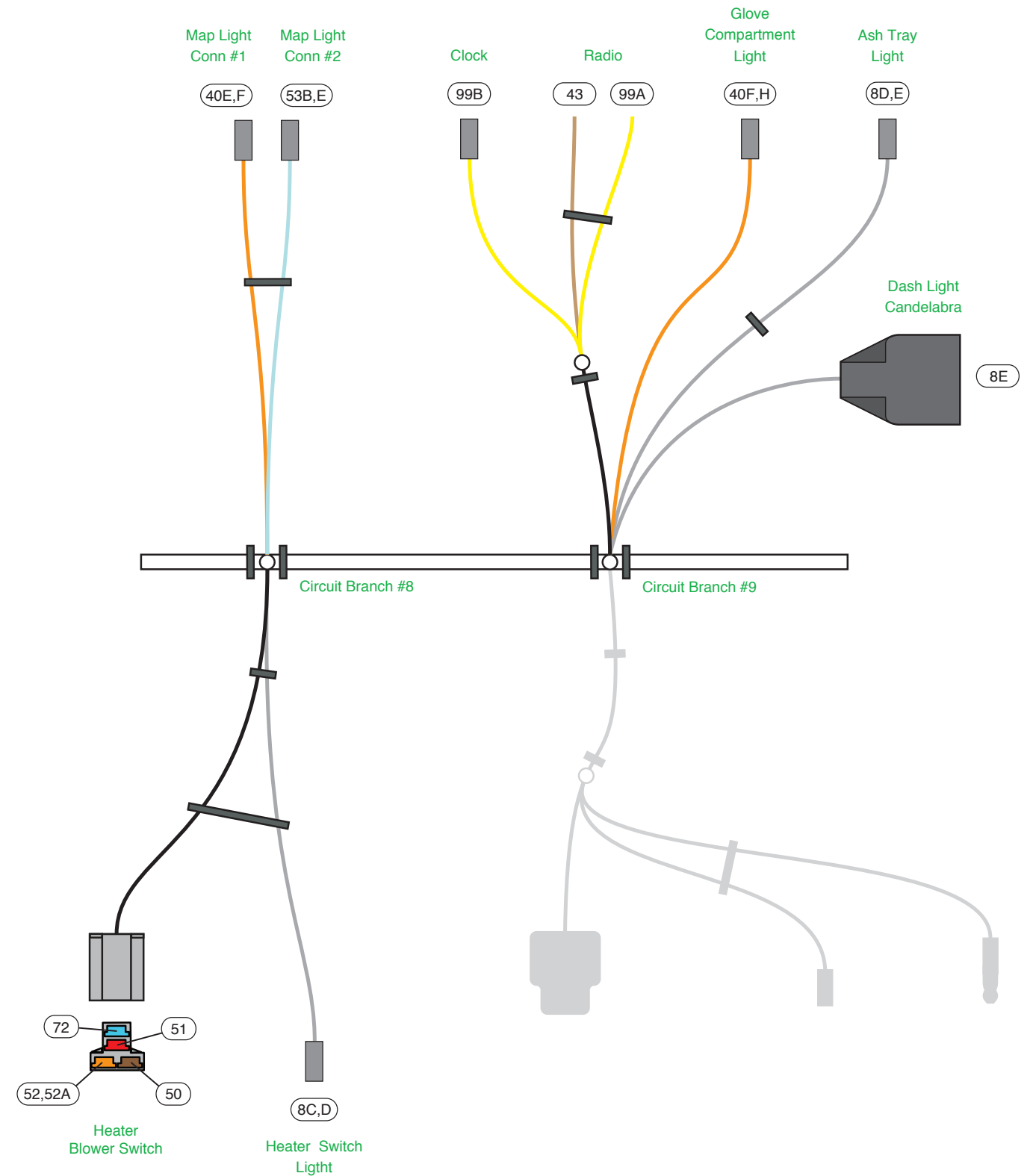

www.americanautowire.com 856-933-0801

PART # **510591**

DESCRIPTION:
1960-64 Ford Galaxie
1961-64 Mercury Full-size
Classic Update Series Kit

92971132 Rev. 0.0 4/16/2015

Blower Motor Resistor Plug this 3-way connector onto your Blower Motor Resistor. For the 1962-64 vehicles you will not use the standalone fourth terminal on the Blower Motor Resistor.

Wire#	Wire Color	Printing	Description
51	Red	no printing	Blower Motor Low Speed.
52A	Orange	no printing	Blower Motor High Speed.
52B	Orange	no printing	Blower Motor feed (1962-64 vehicles).
72	Light Blue	no printing	Blower Motor Medium Speed.

Blower Motor Feed Connector Plug this orange wire onto the orange wire of your Blower Motor Pigtail (1962-64 vehicles). If you need to replace the connector on the Blower Motor pigtail, small male bullet terminal "H" and small sleeve "J", have been provided in kit 510596.

Wire#	Wire Color	Printing	Description
52B	Orange	no printing	Blower Motor feed (1962-64 vehicles).

Blower Motor Ground Connector Plug this black wire onto the black wire of your Blower Motor Pigtail (1962-64 vehicles). If you need to replace the connector on the Blower Motor pigtail, female bullet terminal "X" and large sleeve "D" have been provided in kit 510596.

Wire#	Wire Color	Printing	Description
150C	Black	GROUND	Blower Motor ground (1962-64 vehicles).

Circuit Branch #10 – Under Dash Connections

Right Hand Door Jamb Switch Connection Route the two bullet terminals through the RH Door Jamb Switch hole from behind, and connect to the Door Jamb Switch (item "Y", which is included in kit 510596). Polarity does not matter. Attach the Door Jamb Switch in the original location.

Wire#	Wire Color	Printing	Description
40H	Orange	12V BATTERY-FUSED	12V Fused Battery feed.
53H	Light Blue	12V CTSY SW	Feed to the RH Courtesy Light.

Right Hand Courtesy Light Connector Plug this connector into one Under Dash Courtesy Light Wiring Harness (see page 4, obtain from Bag G) and attach to the lower Instrument Panel. The Courtesy Light Socket requires a #631 Bulb (not Included in this kit).

Wire#	Wire Color	Printing	Description
53E, 53H	Light Blue	12V CTSY SW	12V Switched feed to the Right Hand Courtesy Light.
156B	White	CTSY GROUND	RH Courtesy Light ground. Attach this ring terminal to a good ground.

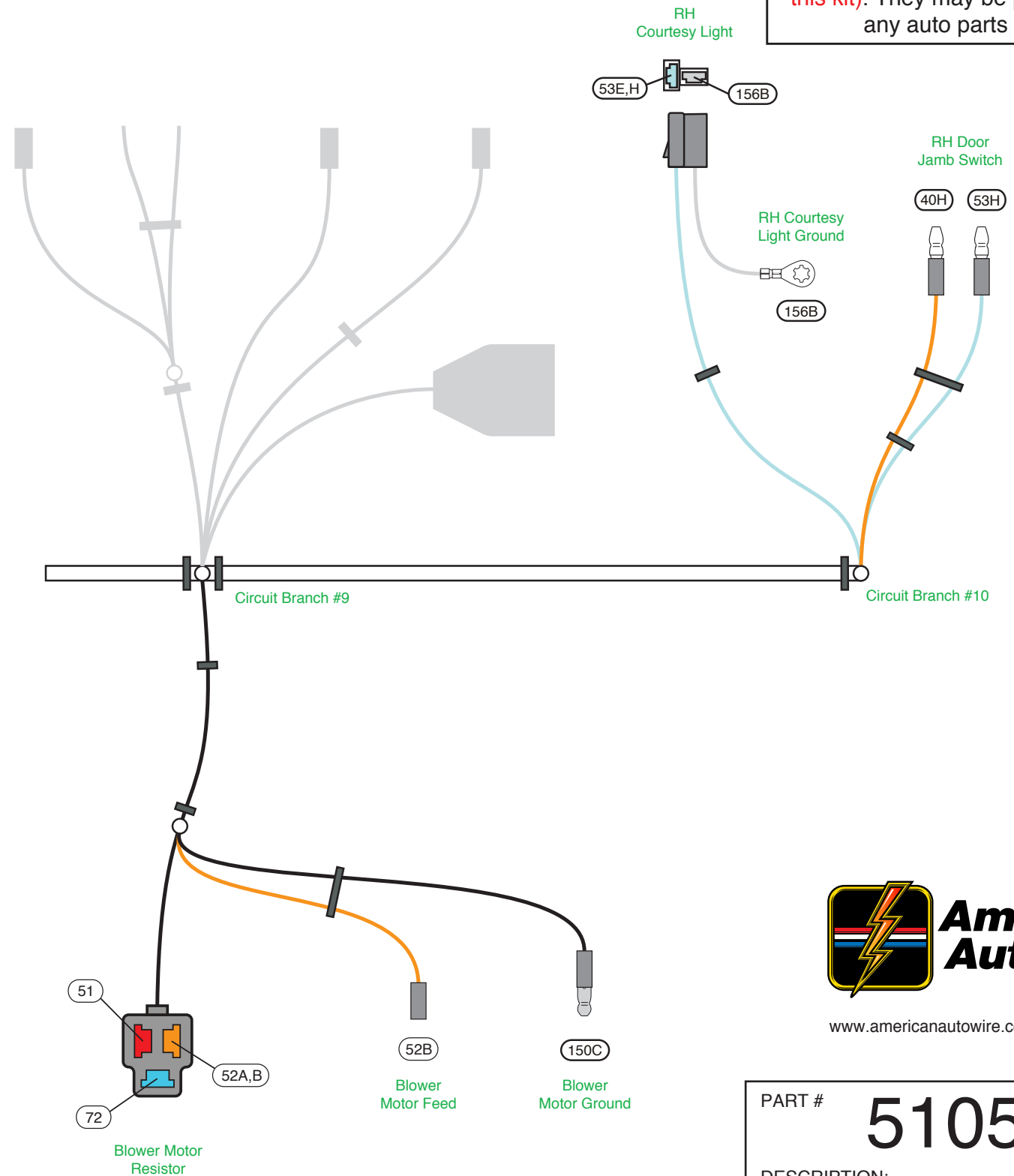

NOTE: The courtesy light extension from page 4, that plugs onto the connector at branch 10 on this page, uses a # 631 bulb (not included with this kit). They may be purchased at any auto parts store.



www.americanautowire.com 856-933-0801

PART # **510591**

DESCRIPTION:
1960-64 Ford Galaxie
1961-64 Mercury Full-size
Classic Update Series Kit

92971132 Rev. 0.0 4/16/2015

AMERICAN AUTOWIRE DASH HARNESS CONNECTION

ORIGINAL TURN SIGNAL SWITCH WIRING

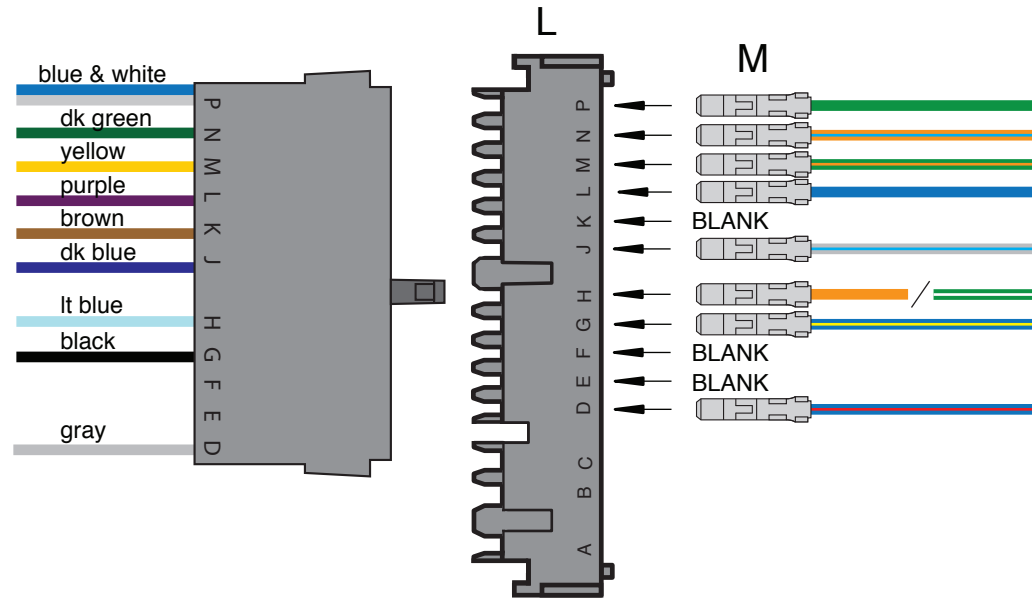

DIAGRAM 'A' - AAW Turn Signal Switch Wires to Stock 1960-64 Steering Columns.

“Table A”

AAW Turn Signal Switch wires to stock 1960-64 Ford Galaxie and 1961-64 Mercury Full-size Turn Signal Switch

AAW Wire #	AAW Wire Color	AAW Wire Printing	Connector Cavity	Ford Wire Color
17A,B	Blue & White	Brake SW	P	Green
19	Dark Green	Right Rear Turn	N	Orange with Blue Stripe
18	Yellow	Left Rear Turn	M	Green with Orange Stripe
16B	Purple	Turn Switch Feed	L	Blue
27B	Brown	Turn SW - Hazard	K	None
15A,B	Dark Blue	Right Front Turn	J	White with Blue Stripe
14A,B	Light Blue	Left Front Turn	H	Orange (1960-62) or Green with White Stripe (1963-64)
28	Black	Horn Relay Ground	G	Blue with Yellow Stripe
None	None	None	F	None
None	None	None	E	None
8A	Gray	Dash Lights	D	Blue with Red Stripe

NOTE: For all of the vehicles, the Steering Column Horn Button switches ground for a Horn Relay, which then switches power to the Horns, similar to the AAW design. Wire 27B is being provided if an Emergency Warning Flasher System is to be added.



www.americanautowire.com 856-933-0801

PART # **510591**

DESCRIPTION:
 1960-64 Ford Galaxie
 1961-64 Mercury Full-size
 Classic Update Series Kit

92971132 Rev. 0.0 4/16/2015

510595 Headlight Extension Harness

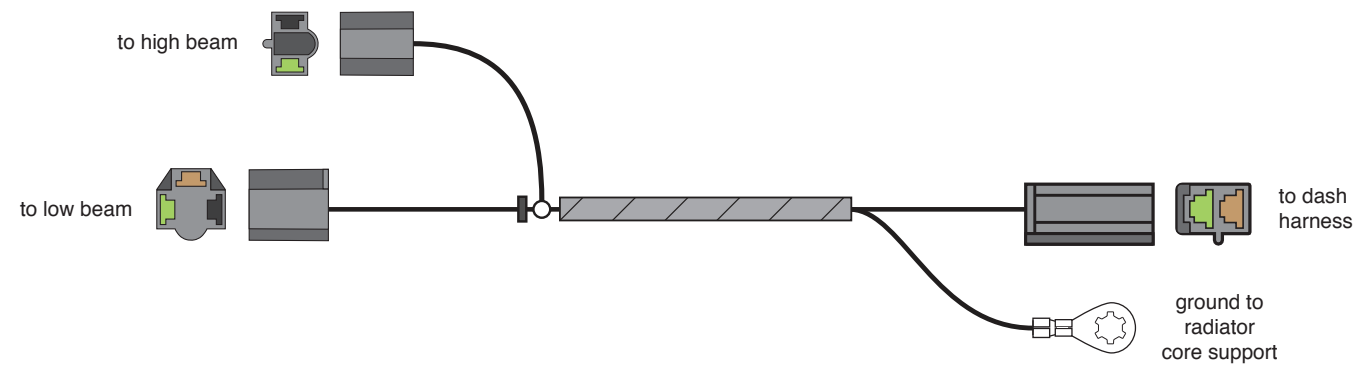
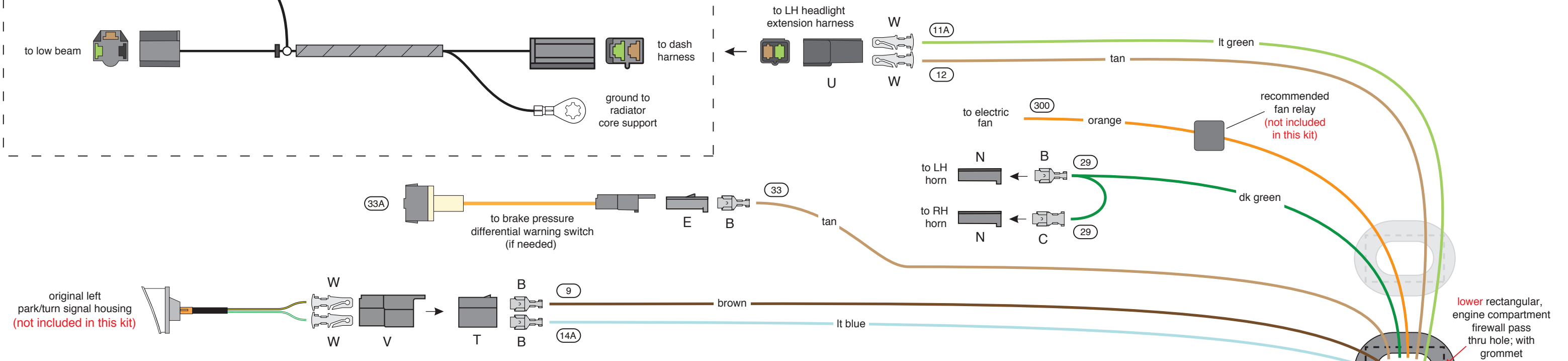

Figure "A"

Left-hand Engine Compartment Wiring
 (lower rectangular firewall hole, located above the Fuse Box)
 Left-hand headlight, parking/turn light, horn, brake warning and fan relay.
 These wires are all found at branch 1, pages 5 and 6.



NOTE: See the Fuse Block Mounting Instructions 92971155, for the grommet installation and wire routing, through the Firewall. After completing these tasks, apply silicone sealer to these areas to make a weather tight seal.

Figure "D"

Shown is a typical NSS and Back Up Switch.

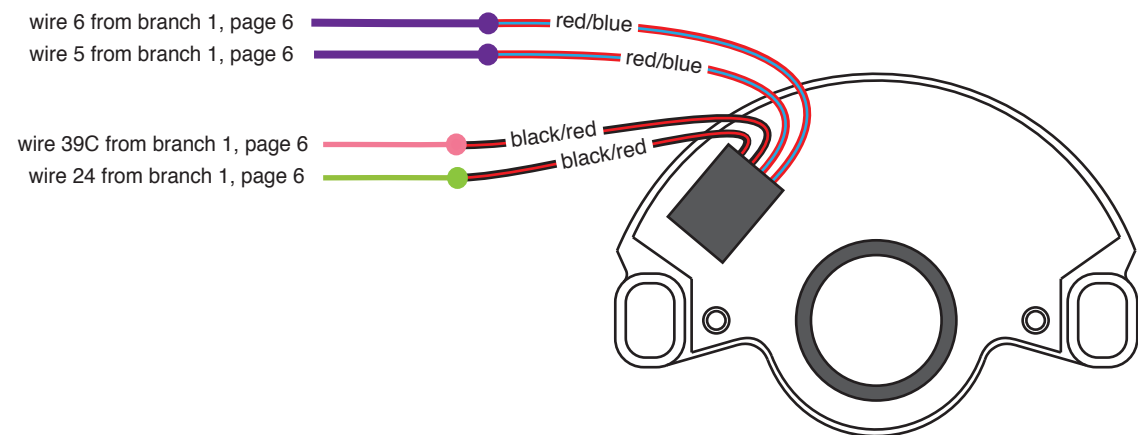

See Figure "D", for Neutral Safety Switch and Back Up Switch connections

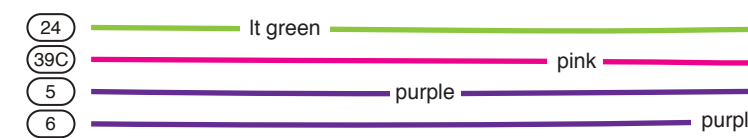

NOTE: The terminals and connectors listed on this page and denoted with **UPPER CASE LETTERS**, to help you complete the various connections to your left-hand engine compartment lights, horns, switches, brake warning, electric fan, back-up and NSS switches, can be found in your loose piece, clamp, grommet and parts kit, P/N 510596.

The identifications, colors, and functions, for all of the wires listed in "Figure A" and "Figure D", on this page, can be found on pages 5 and 6, branch 1, of this instruction set and in the Headlight Harness kit.



www.americanautowire.com 856-933-0801

PART # **510591**

DESCRIPTION:
 1960-64 Ford Galaxie
 1961-64 Mercury Full-size
 Classic Update Series Kit

92971132 Rev. 0.0 4/16/2015

Figure "B"

Right-hand Engine Compartment Wiring
(upper rectangular firewall hole, located above the Fuse Box)

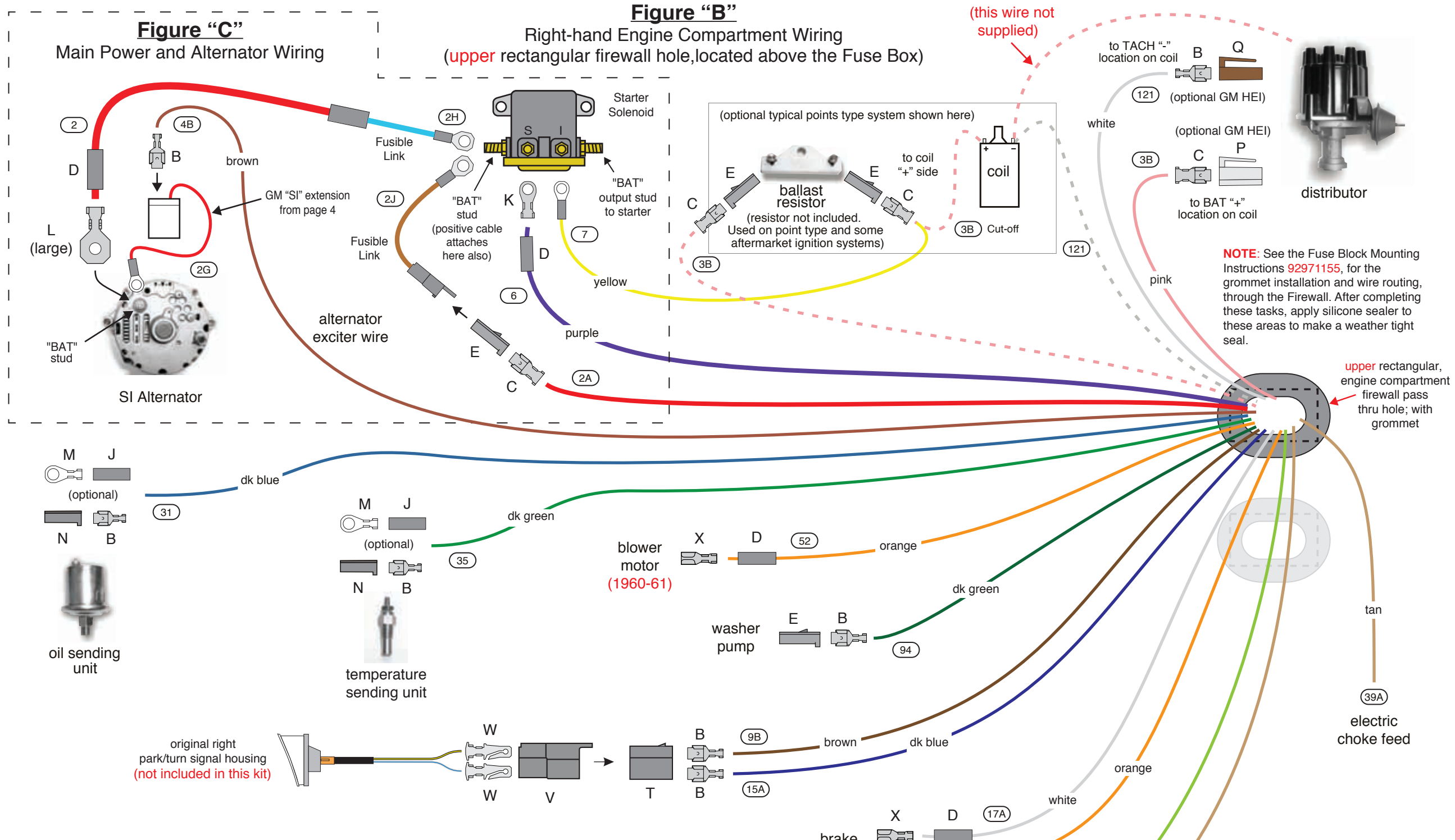

(this wire not supplied)

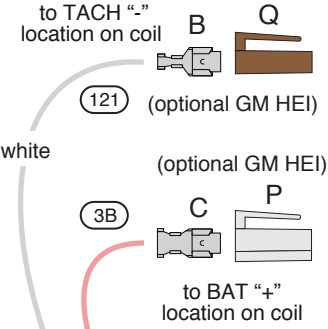

NOTE: See the Fuse Block Mounting Instructions 92971155, for the grommet installation and wire routing, through the Firewall. After completing these tasks, apply silicone sealer to these areas to make a weather tight seal.

upper rectangular, engine compartment firewall pass thru hole; with grommet

NOTE: The terminals and connectors listed on this page and denoted with **UPPER CASE LETTERS**, to help you complete the various connections to your right-hand engine compartment lights, ignition feed, engine sensors, electric choke, tachometer, washer pump, blower motor, brake switch and alternator output, can be found in your loose piece, clamp, grommet and parts kit, P/N 510596.

The identifications, colors, and functions, for all of the wires listed in "Figure B" and "Figure C", on this page, can be found on pages 7 and 8, branch 2, of this instruction set and in the Headlight Harness kit.

AAW kits are all engineered to be used in conjunction with a high output, later model internally regulated, or one wire alternators. We do not suggest or support the use of a stock, low amperage alternator, as they do not supply sufficient current to recharge the battery in a highly modified car such as this kit was designed for. AAW suggests a Ford Gen III (3G), a GM "SI", or a 1 wire type alternator as good choices to use. An adapter to complete the connection to the Ford Gen III (3G) style alternator (AAW p/n 500802) may be purchased separately. Contact AAW for your needs.

Figure "C"

Main Power and Alternator Wiring

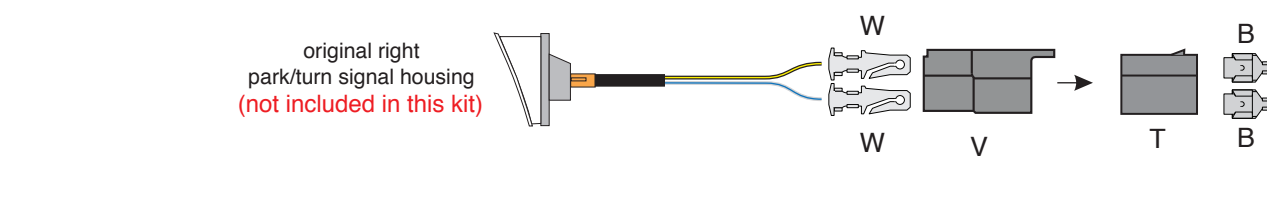
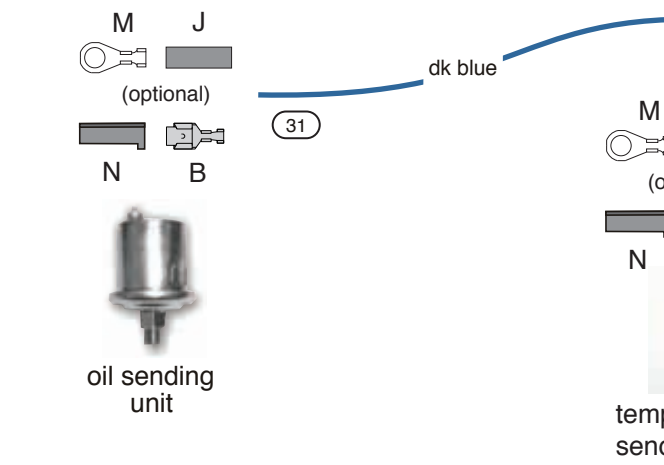
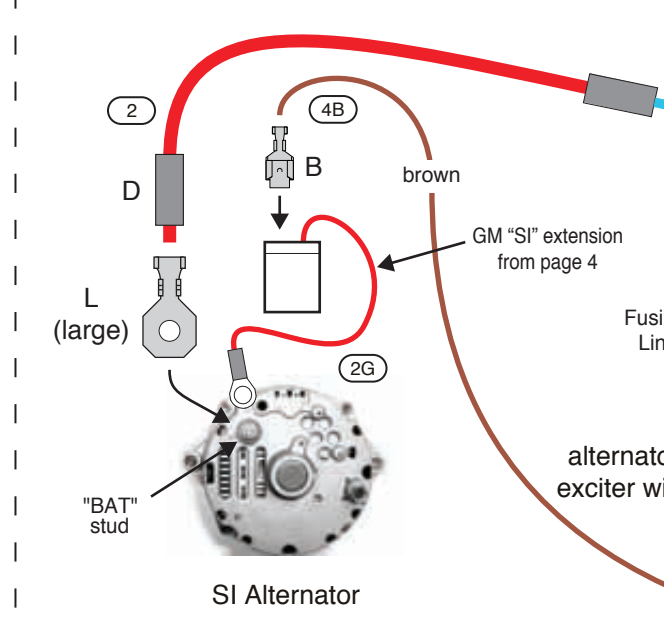

510595 Headlight Extension Harness

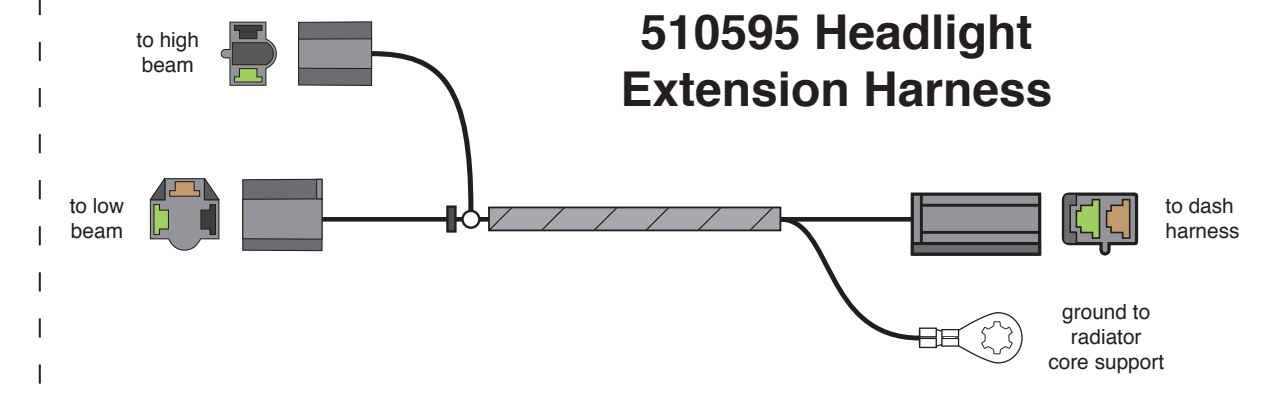

www.americanautowire.com 856-933-0801

PART # **510591**

DESCRIPTION:
1960-64 Ford Galaxie
1961-64 Mercury Full-size
Classic Update Series Kit

92971132 Rev. 0.0 4/16/2015

Shown is "1960-61 Wiper Jumper w/o Washer", connected to the Dash Harness.

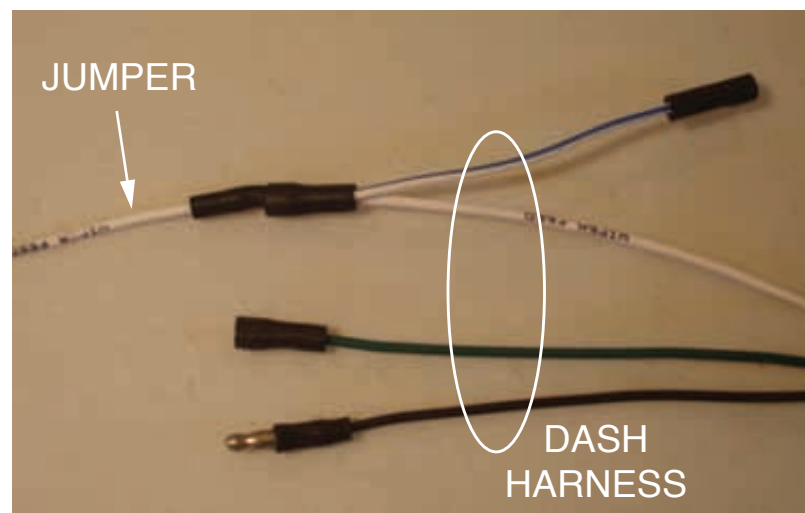

Shown is "1960-61 Wiper Jumper with Washer", connected to the Dash Harness.

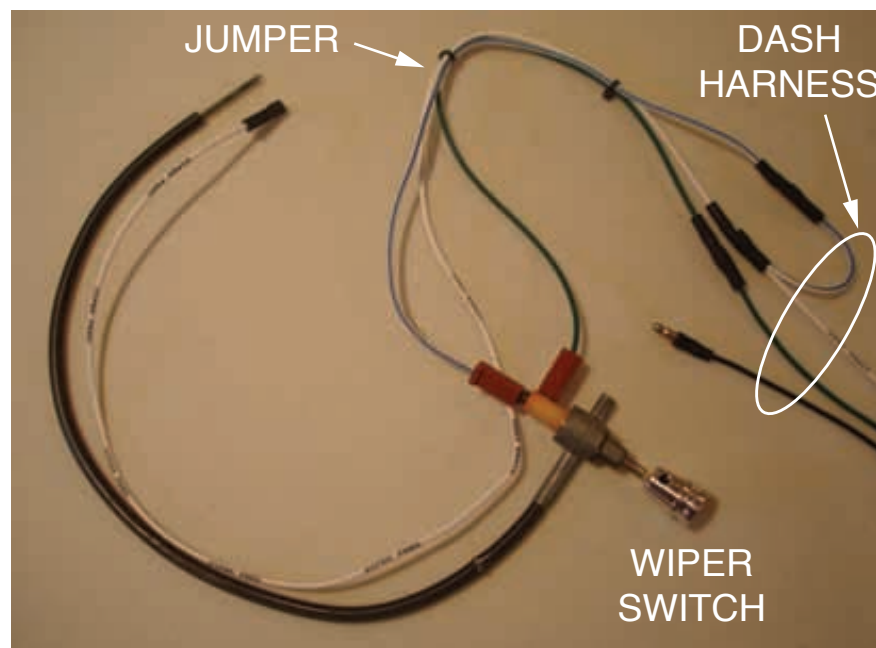

Shown is "1962 Wiper Jumper 1-Speed with Washer", connected to the Dash Harness.

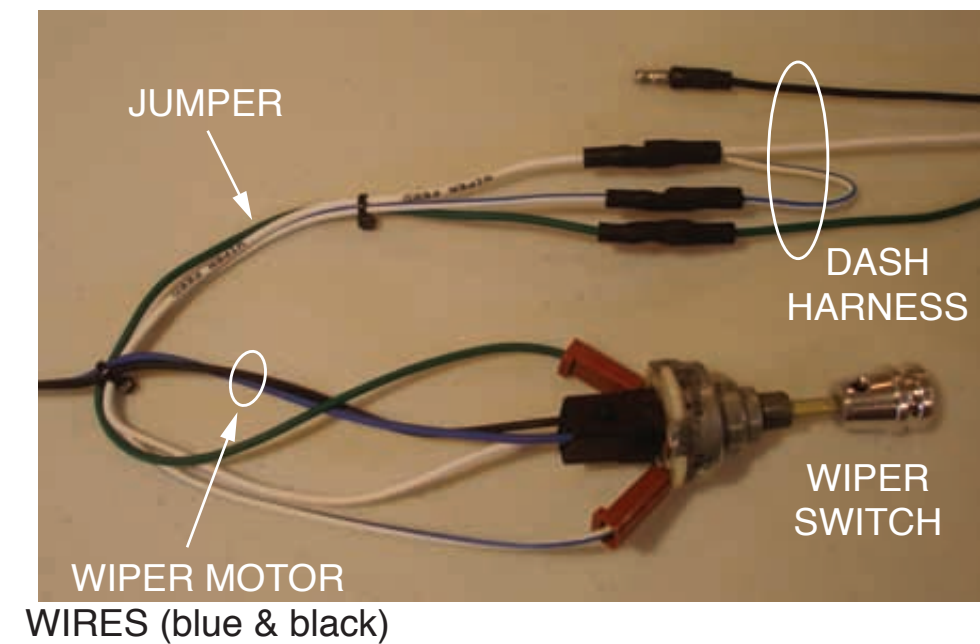

Shown is 1963 original Wiper harness, connected to the Dash Harness.

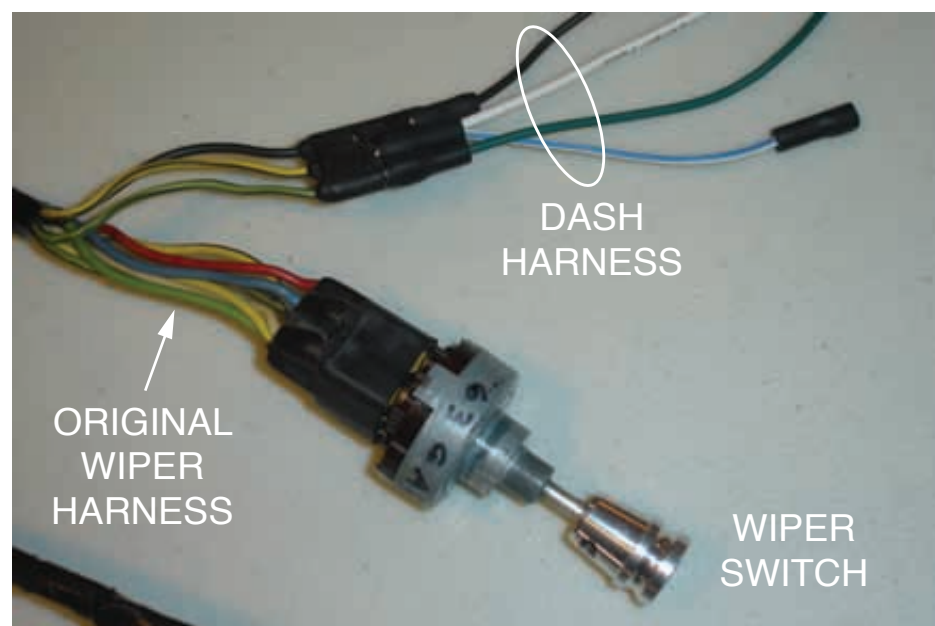

Shown is 1964 original Wiper harness, connected to the Dash Harness.

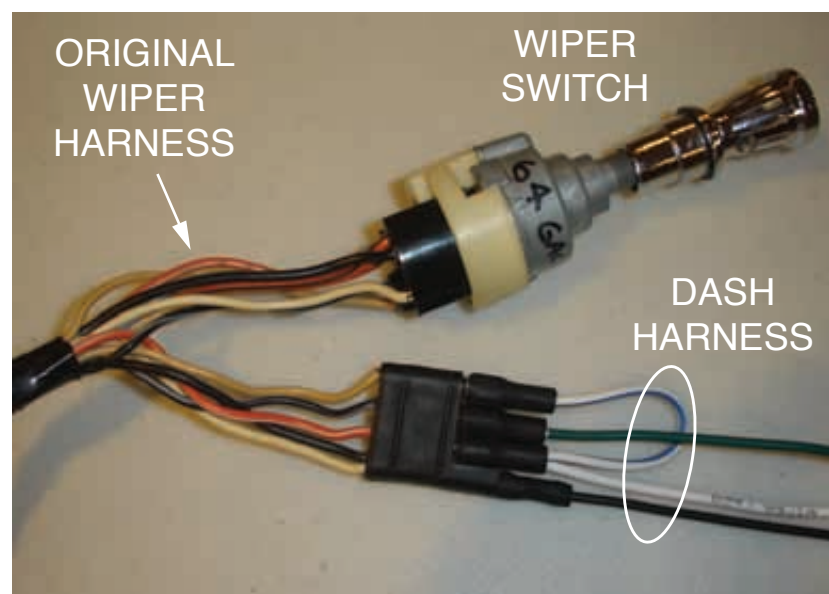

FUSE LOCATIONS

NOTE: This is an image of the completed Fuse Box assembly, depicting the proper location for the installation of each fuse.

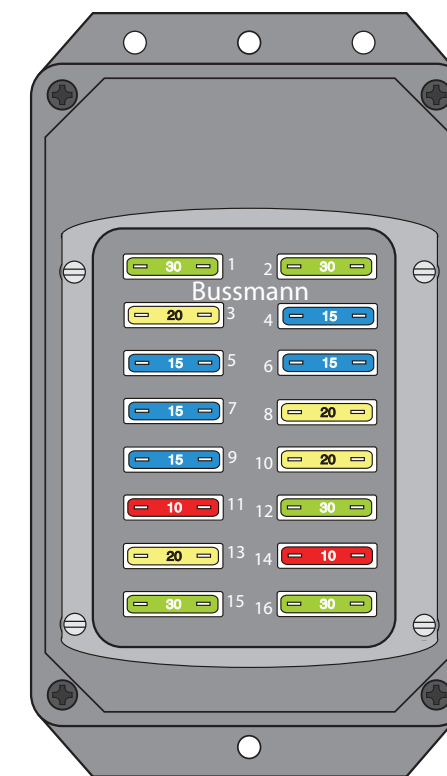

PART # **510591**

DESCRIPTION:
 1960-64 Ford Galaxie
 1961-64 Mercury Full-size
 Classic Update Series Kit

92971132 Rev. 0.0 4/16/2015



www.americanautowire.com 856-933-0801