

You will use this main instruction sheet, **92971527**, to complete the installation process of bag **G**. See page six of this instruction set and Bulkhead Connector Assembly Mounting Instruction Sheet **92971552**, to begin.

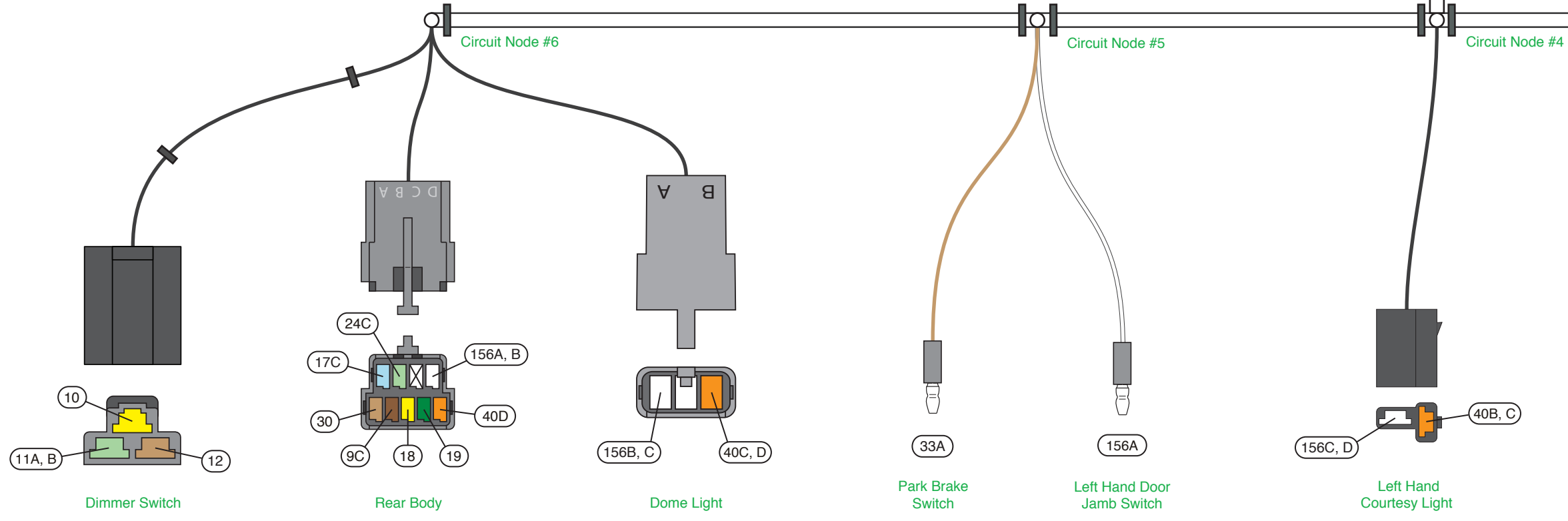

DASH/MAIN HARNESS
 1968-70 Mopar B-body
 Classic Update Series

510635
 4/29/2016 Rev 0.0 JM

92971527

bag
G

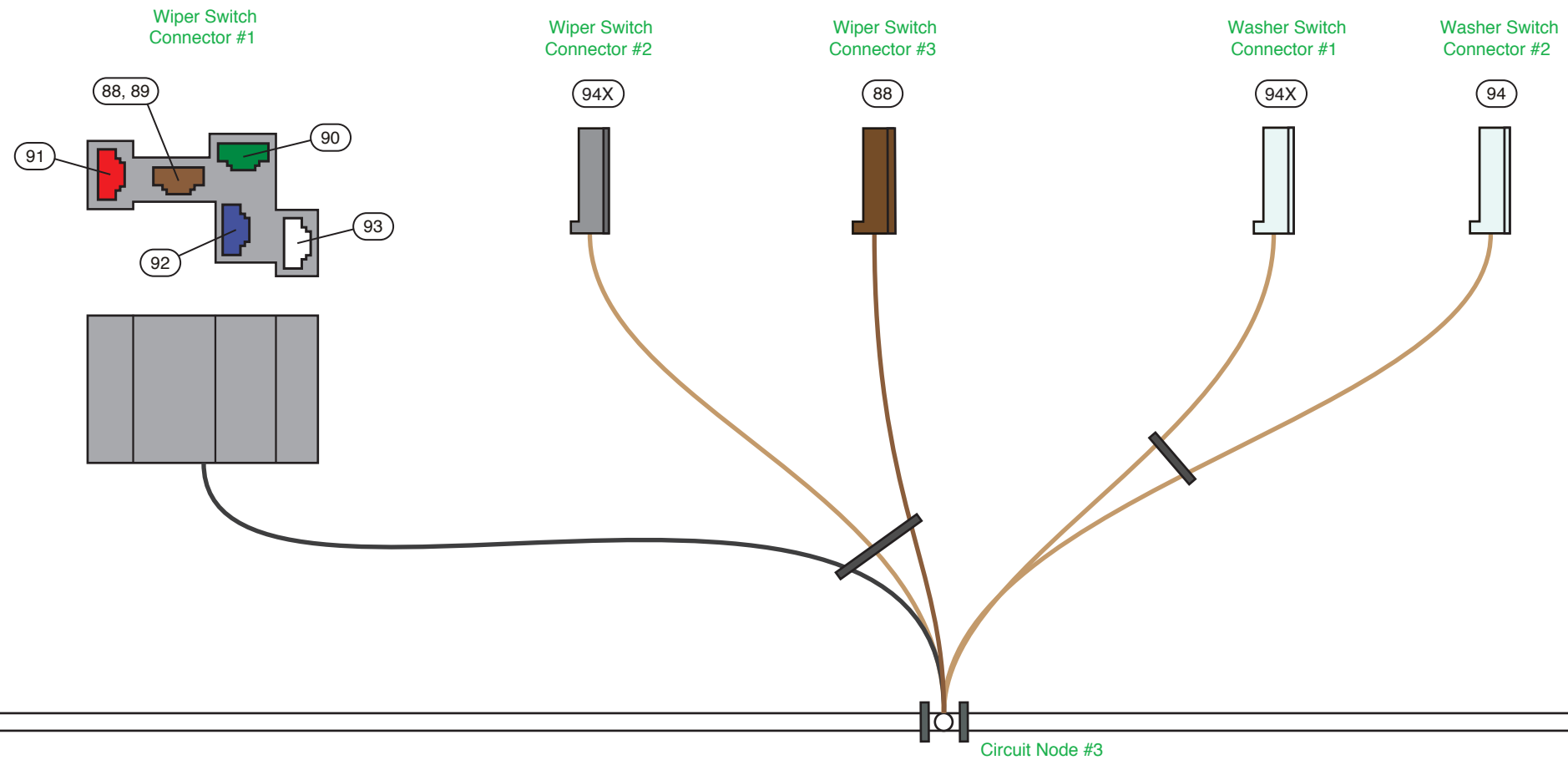

DASH/MAIN HARNESS

1968-70 Mopar B-body
Classic Update Series

510635

4/29/2016 Rev 0.0 JM

Wiring-side of Bulkhead Connector, is shown.

Bulkhead Assembly

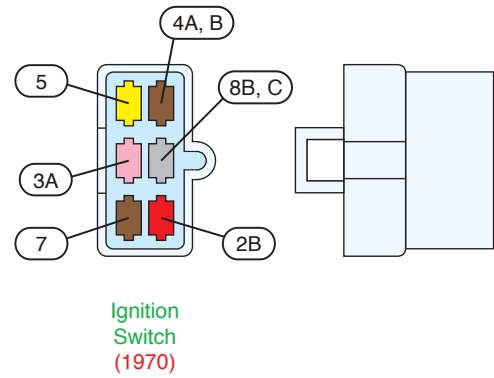
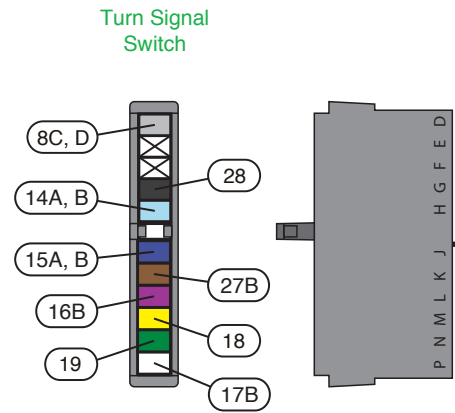
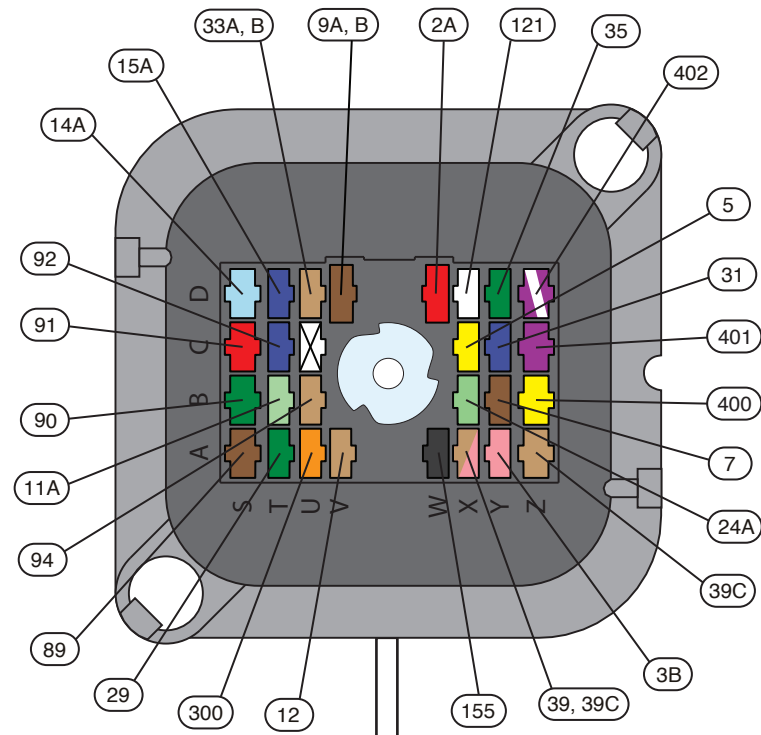

Stop Light Switch
Clutch Switch Manual Trans (1970)

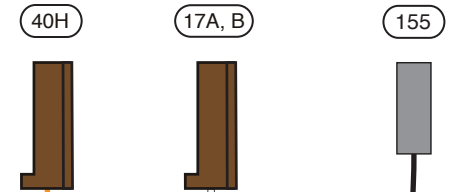

Circuit Node #1

Circuit Node #2

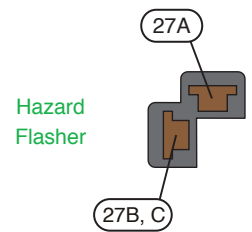

Radio

99

43

Ground

150A

8G Dash Light Candelabra

24B, C Reverse Warning Light

DASH/MAIN HARNESS

1968-70 Mopar B-body Classic Update Series

510635

4/29/2016 Rev 0.0 JM

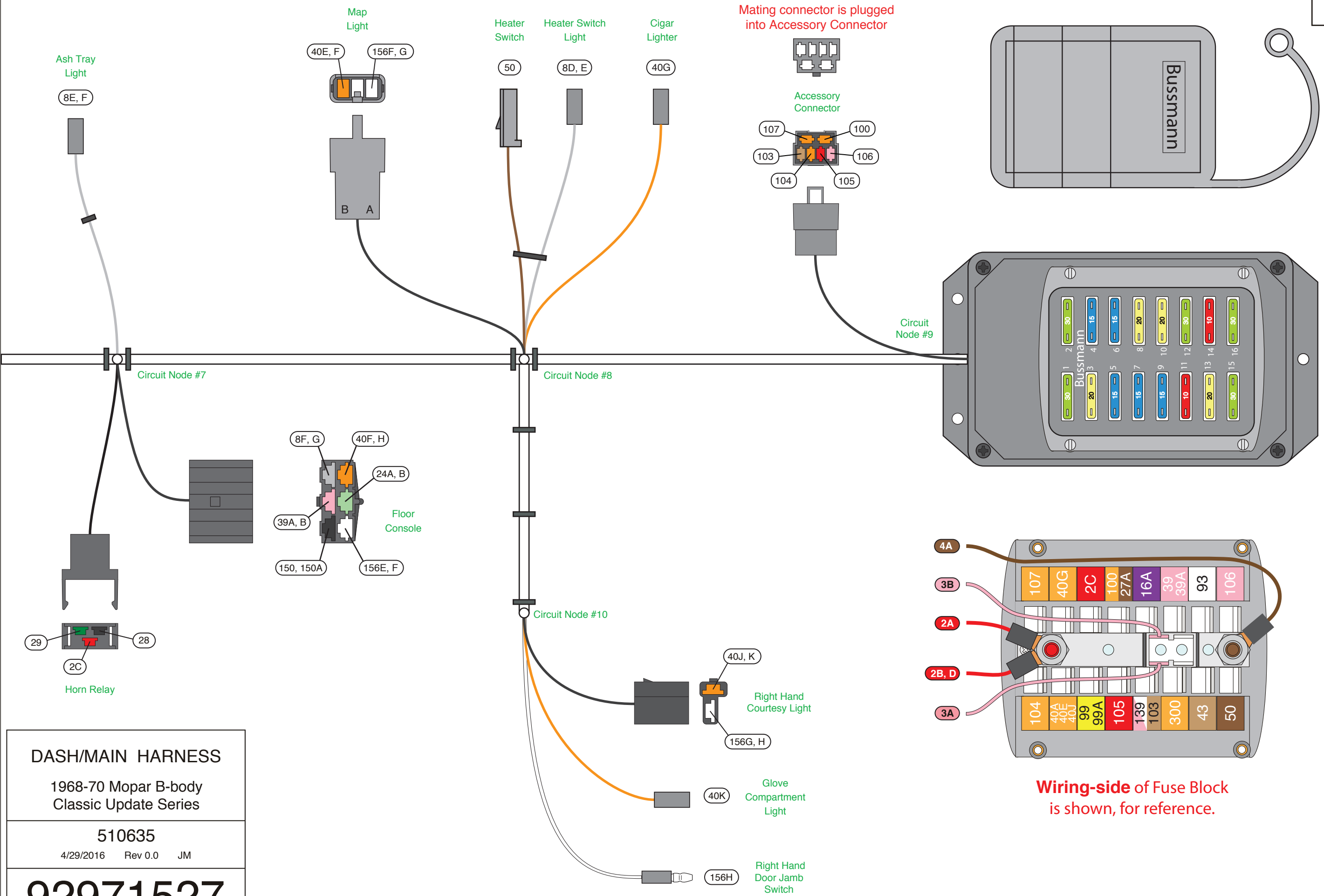

Fuse Installation Orientation

Wiring-side of Fuse Block is shown, for reference.

DASH/MAIN HARNESS

1968-70 Mopar B-body
Classic Update Series

510635

4/29/2016 Rev 0.0 JM

92971527

Legend:

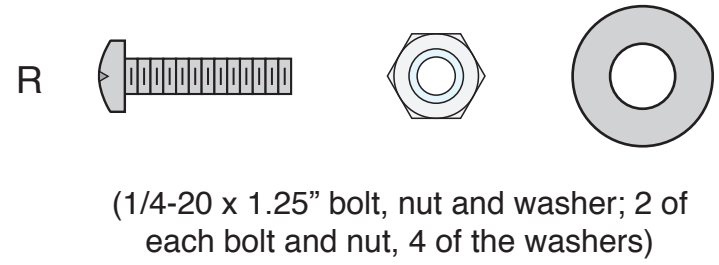
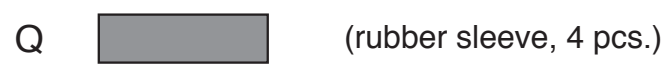
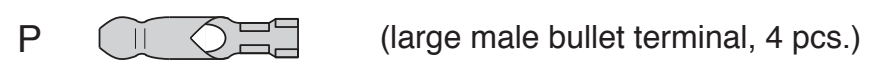
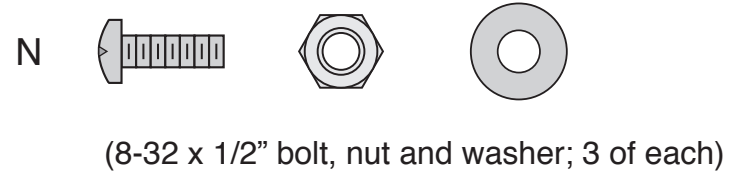
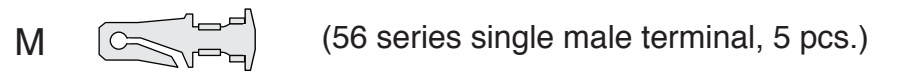
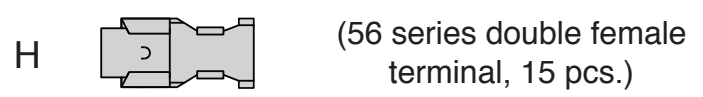
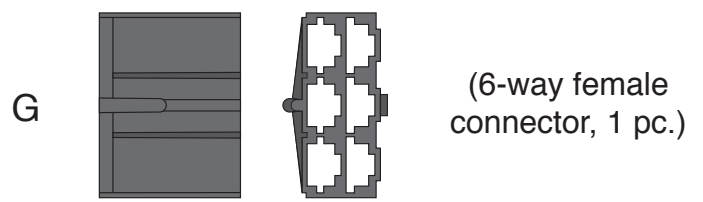
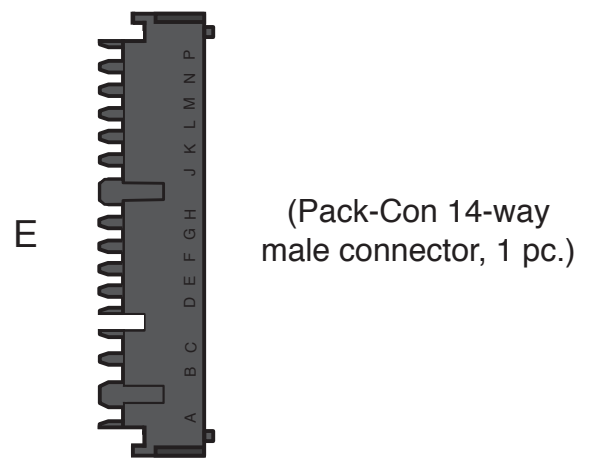
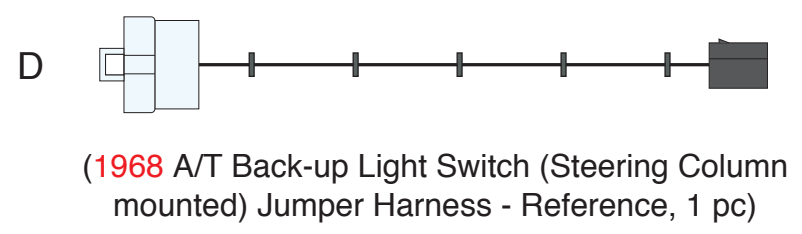
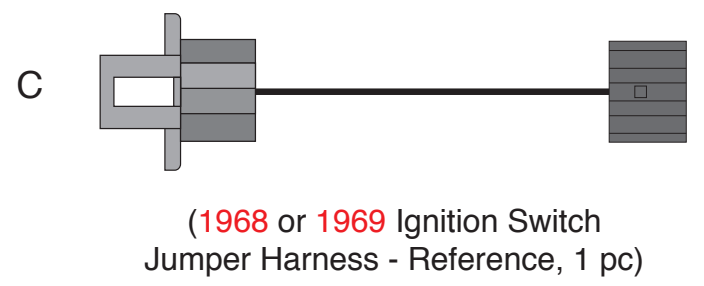
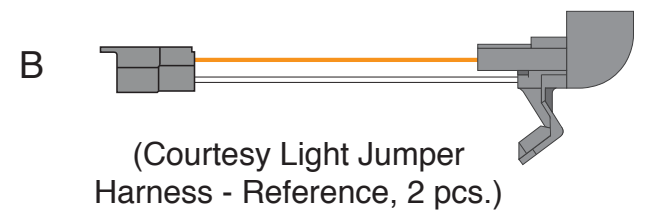
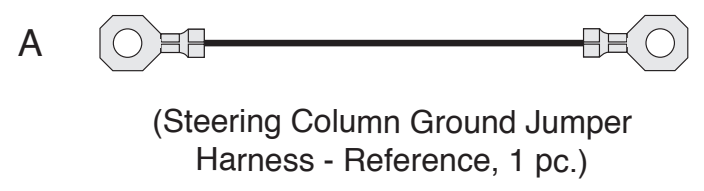

DASH/MAIN HARNESS		
1968-70 Mopar B-body Classic Update Series		
510635		
4/29/2016	Rev 0.0	JM
92971527		

Note: Prior to installing the Dash Harness, obtain the Fuse, Flasher, and Relay Kit #510557 (located in Bag G) and plug all of the Fuses in the Fuse Block (See page 4 for the location of the fuses). Install the Horn Relay (see Circuit Node #7) and the two Flashers to the Dash Harness (see Circuit Nodes #2 and #4).

Steering Column Ground

Obtain the **Steering Column Ground Jumper Harness "A"** from the **Dash Harness Kit Bag G**. See the Legend on **page 5** for an illustration of the Jumpers and the wiring components. This 1-wire jumper will replace the existing original ground jumper and will use the same fasteners. Attach the **Steering Column Ground Jumper Harness "A"** to the Steering Column and to the lower Dash.

Dash Harness Routing

The Dash Harness routing will be the same as the original factory Instrument Panel Wiring Harness routing. Be sure to duplicate this routing. The new Dash Harness is in the shape of a T. One segment of the trunk of the T will route to the right towards the Glove Box, one segment of the trunk will route to the left towards the Cluster, and the last segment of the trunk will route towards the Firewall. Now proceed to the individual Circuit Node Instructions below.

Circuit Node #1

Bulkhead Assembly Attachment

Locate the original factory Bulkhead Connector rectangular hole in the left center of the Firewall. The new Bulkhead Assembly will mount in this same Firewall hole (see photo #1). When the Bulkhead Connector is attached to the Firewall, the wires of the Dash Harness, inside the car, will initially route downward. Two pass-through holes will be required for the 1/4 - 20 x 1.25 machine screws. See the Bulkhead Attachment Instructions 92971522 for mounting the Bulkhead Assembly. Use **2 Screws, 4 Washers, and 2 Locking Nuts** (item "R" from **Loose Parts Kit 92971528**) to attach the Bulkhead Assembly to the Firewall. **NOTE: A Washer will be under the head of each Machine Screw and another Washer will be under each Locking Nut.**

Attach the Main Trunk of the Dash Harness adjacent to the center lower clip of the Instrument Panel similar to the original wiring (see Photo #2).

Turn Signal Switch Preparation NOTE: For all of the vehicles, the Turn Signal Switch is mounted to the Steering Column. You will continue to use this original Turn Signal Switch, but will have to remove the original connector from the pigtail and replace this connector with the black 14-way connector "E" and terminals "F" (located in Parts Kit 92971528 in Bag G). See Diagram 'A' and Diagram 'B' plus "Table B" on page 12 for details.

Turn Signal Switch Connector Once you have modified the original Turn Signal Switch Pigtail by adding the black 14-way male connector "E", obtain the 11-way Turn Signal Switch connector, which is part of the Dash Harness, and plug it into the 14-way connector "E" of the Turn Signal Switch.

Wire #	Wire Color	Printing	Description
8C, D	Gray	DASH LIGHTS	Steering Column PRNDL Light Illumination feed for the 1968-69 vehicles.
14A, B	Light Blue	LEFT FRONT TURN	Left Front Turn Signal feed.
15A, B	Dark Blue	RIGHT FRONT TURN	Right Front Turn Signal feed.
16B	Purple	TURN SWITCH FEED	Turn Signal Switch feed from the Turn Signal Flasher.
17B	White	BRAKE SW	Brake Switch feed to the Turn Signal Switch.
18	Yellow	LEFT REAR TURN	Feed to the Left Rear Turn Signal Light.
19	Dark Green	RIGHT REAR TURN	Feed to the Right Rear Turn Signal Light.
27B	Brown	TURN SW - HAZARD	Feed from the Hazard Flasher.
28	Black	HORN RELAY	Ground from the Horn Relay to the Horn Switch.

Ignition Switch (1968-69) NOTE: For the 1968-69 vehicles, the Ignition Switch is located on the IP. You will obtain the Ignition Switch Jumper Harness "C" from Bag G and plug the black 6-way connector into the white 6-way Ignition Switch Connector on the Dash Harness and then connect the Ignition Switch connector to the Ignition Switch.

Ignition Switch Jumper Harness (1968-69) This is the Jumper Harness "C" that will plug into the 6-way white connector on the Dash Harness and the 1968-69 Ignition Switch.

Wire #	Wire Color	Printing	Description
2X	Red	12V BATTERY	12V Battery feed.
3X	Pink	IGNITION FEED	12V Ignition feed.
4X	Brown	IGNITION SW ACCY	12V Ignition Accessory feed.
5X	Yellow	no printing	Start circuit.
7X	Brown	no printing	Ignition feed during crank to the Ignition Coil.



Ignition Switch (1970) Pigtail Preparation NOTE: For the 1970 vehicles, the Ignition Switch is mounted to the Steering Column. You will continue to use this original Ignition Switch, but will have to remove the original connector from the pigtail and replace the connector with the black 6-way connector "G" and terminals "H" and "J" (from Parts Kit 92971528 in Bag G). See "Table A" on page 12 for details. Note: the additional two thin red wires in the Ignition Switch pigtail are for the Key-in Ignition Warning Buzzer and will not be used.

Ignition Switch Connector (1970 Vehicles) Once you have modified the original Ignition Switch Pigtail by adding the black 6-way connector "G", obtain the white 6-way Ignition Switch connector, which is part of the Dash Harness, and plug it into the black 6-way connector "G" of the Ignition Switch.

Wire #	Wire Color	Printing	Description
2B	Red	12V BATTERY	12V Battery feed.
3A	Pink	IGNITION FEED	12V Ignition feed from the Ignition Switch.
4A	Brown	IGNITION SW ACCY	12V Accessory feed from the Ignition Switch.
4B	Brown	no printing	12V Accessory feed to the Cluster.
5	Yellow	no printing	Start circuit.
7	Brown	no printing	Ignition feed during crank to the Ignition Coil.
8B, C	Gray	DASH LIGHTS	Illumination Light feed wires to the PRNDL Light on the Steering Column (if so equipped).

Stop Light Switch Connectors Connect these two 1-way brown connectors to the Brake Switch; polarity doesn't matter.

Wire #	Wire Color	Printing	Description
17A, B	White	BRAKE SW	Brake Switch feed to the Turn Signal Switch.
40H	Orange	BRAKE SW	12V Battery Fused feed from the Fuse Block.

Clutch Switch (1970 with Manual Transmission) NOTE: For the 1970 vehicles equipped with a Manual Transmission, when the Clutch Pedal is depressed, the Clutch Switch will provide a ground path for the ground "G" terminal of the Starter Relay through wire 155. This will allow the Engine to crank when the Ignition Switch is rotated to the Start position. For the 1968-69 vehicles, this Clutch Switch Connector can be taped back.

Clutch Switch Connector (1970) Connect the 1-way female bullet Clutch Switch connector to the Clutch Interlock Switch pigtail.

Wire #	Wire Color	Printing	Description
155	Black	no printing	Ground wire from the Starter Relay to the Clutch Switch.

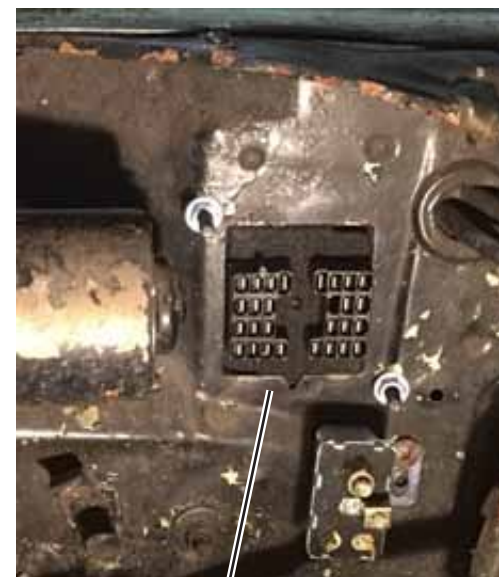
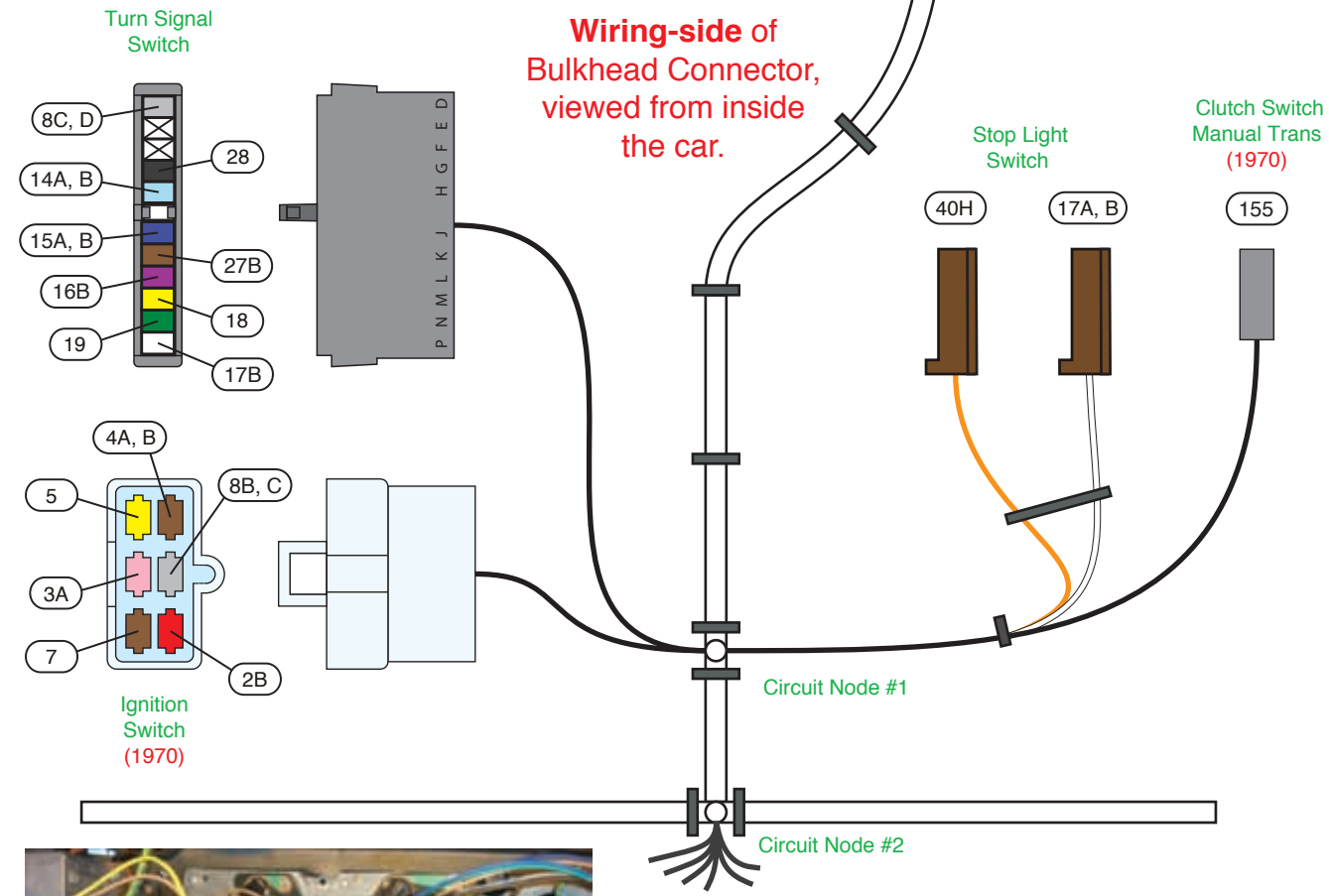
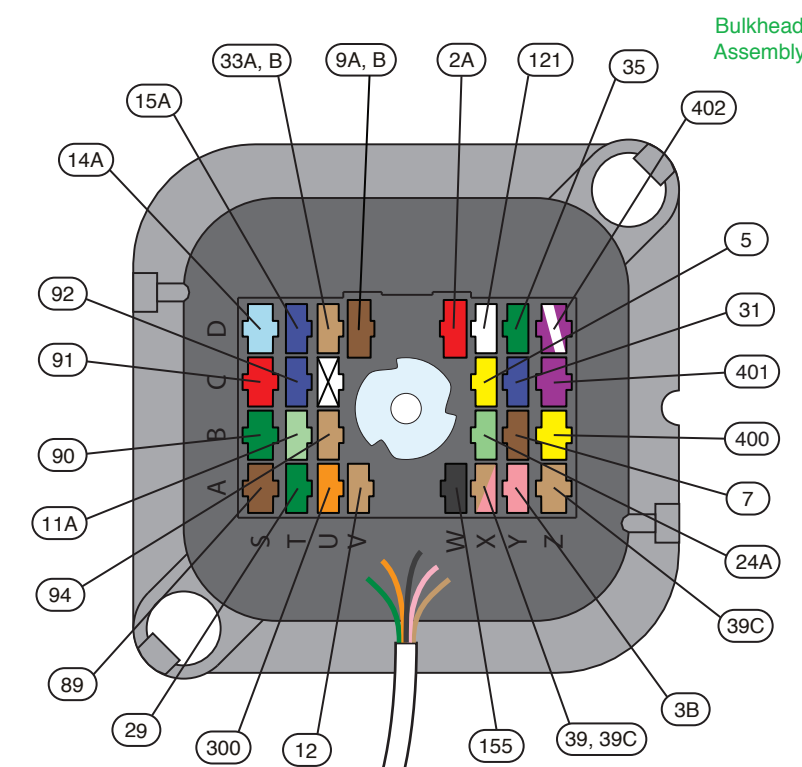

Photo #1 Bulkhead connector as seen from engine compartment side of firewall



Circuit Node #2, at the center lower clip of the Instrument Panel

510635
92971527
Rev. 0.0
4/29/2016

Circuit Node #2

Hazard Flasher Connector If you haven't already; plug one of the **Flashers** (included in kit #510557 in **Bag G**) into this connector. Attach the Flasher to the original metal Flasher Retainer on the IP, if so equipped.

Wire #	Wire Color	Printing	Description
27A	Brown	TURN SW-HAZARD	12V Battery feed to the Hazard Flasher.
27B, C	Brown	TURN SW-HAZARD	12V feed from the Hazard Flasher.

Radio Wires These wires are provided for your Radio.

Wire #	Wire Color	Printing	Description
43	Tan	RADIO	12V Fused Accessory Feed to the Radio for "On/Off" power.
99	Yellow	RADIO BAT	12V Fused Battery Feed for the Radio Memory.

Ground **Note: Be sure to attach this ground ring terminal to a good vehicle ground. If not attached to ground, your Cluster Lights may not be functional.**

Wire #	Wire Color	Printing	Description
150A	Black	GROUND	Ground wire.

Reverse Warning Light Connector (4-spd Manual Transmission Vehicles only) This connector provides a feed to the Reverse Gear Warning Light that is mounted on the lower Dash for Manual Transmission vehicles. Plug the pigtail of your original Reverse Light into this connector.

Wire #	Wire Color	Printing	Description
24B, C	Light Green	BACK UP LT SW --> LIGHTS	Feed from the Back-up Light Switch.

Dash Light Candelabra This 3-way female bullet connector provides a connection point for any Illumination Light feed that may be required, such as to the Radio, an Aftermarket Tachometer, the Ignition Switch Illumination Light, etc. This is the same circuit as the Instrument Cluster Illumination Lights and will dim when the Panel Dimmer Switch Knob is rotated. Extra wire length of the gray "DASH LIGHTS" wire (circuit 8) is available in the **Cluster Kit 510636 in Bag H**. Also, male bullet terminals "P" and sleeves "Q" (to plug into the **Candelabra** Connector) are available in the **Dash Harness Parts Kit 92971528 in Bag G** for this application.

Wire #	Wire Color	Printing	Description
8G	Gray	DASH LIGHTS	Dash Lights feed wire.

Circuit Node #3

Wiper Switch Connector #1 Plug this 5-way connector to the Wiper Switch.

Wire #	Wire Color	Printing	Description
88	Brown/White	no printing	This is a resistance wire which is part of the 3-speed Wiper System circuitry.
89	Brown	no printing	Armature feed from the Wiper Switch to the Wiper Motor.
90	Dark Green	no printing	Motor Field #1 feed from the Wiper Switch to the Wiper Motor.
91	Red	no printing	Motor Field #2 feed from the Wiper Switch to the Wiper Motor.
92	Dark Blue	no printing	Park feed from the Wiper Switch to the Wiper Motor.
93	White	WIPER FEED	Fused 12V Accessory feed from the Fuse Block to the Wiper Switch.

Wiper Switch Connector #2 This is the 1-way black connector with a notch on the side. Plug this black connector to the Wiper Switch terminal **B/U** with the nib on the side.

Wire #	Wire Color	Printing	Description
94X	Tan	no printing	12V feed from the Wiper Switch to the Washer Switch for the Washer Pump.

Wiper Switch Connector #3 Plug this brown 1-way connector to the 3-speed Wiper Switch terminal "R". This wire is only used with the 3-speed Wiper System.

Wire #	Wire Color	Printing	Description
88	Brown/White	no printing	This is a resistance wire which is part of the 3-speed Wiper System circuitry.

Washer Switch Connector #1 Plug this 1-way white connector to either one of the Washer Switch terminals. This is the 12V feed to the Washer Switch.

Wire #	Wire Color	Printing	Description
94X	Tan	no printing	12V feed from the Wiper Switch to the Washer Switch for the Washer Pump.

Washer Switch Connector #2 Plug this 1-way white connector to the second Washer Switch terminal.

Wire #	Wire Color	Printing	Description
94	Tan	no printing	12V feed from Washer Switch to the Electric Washer Pump Motor.

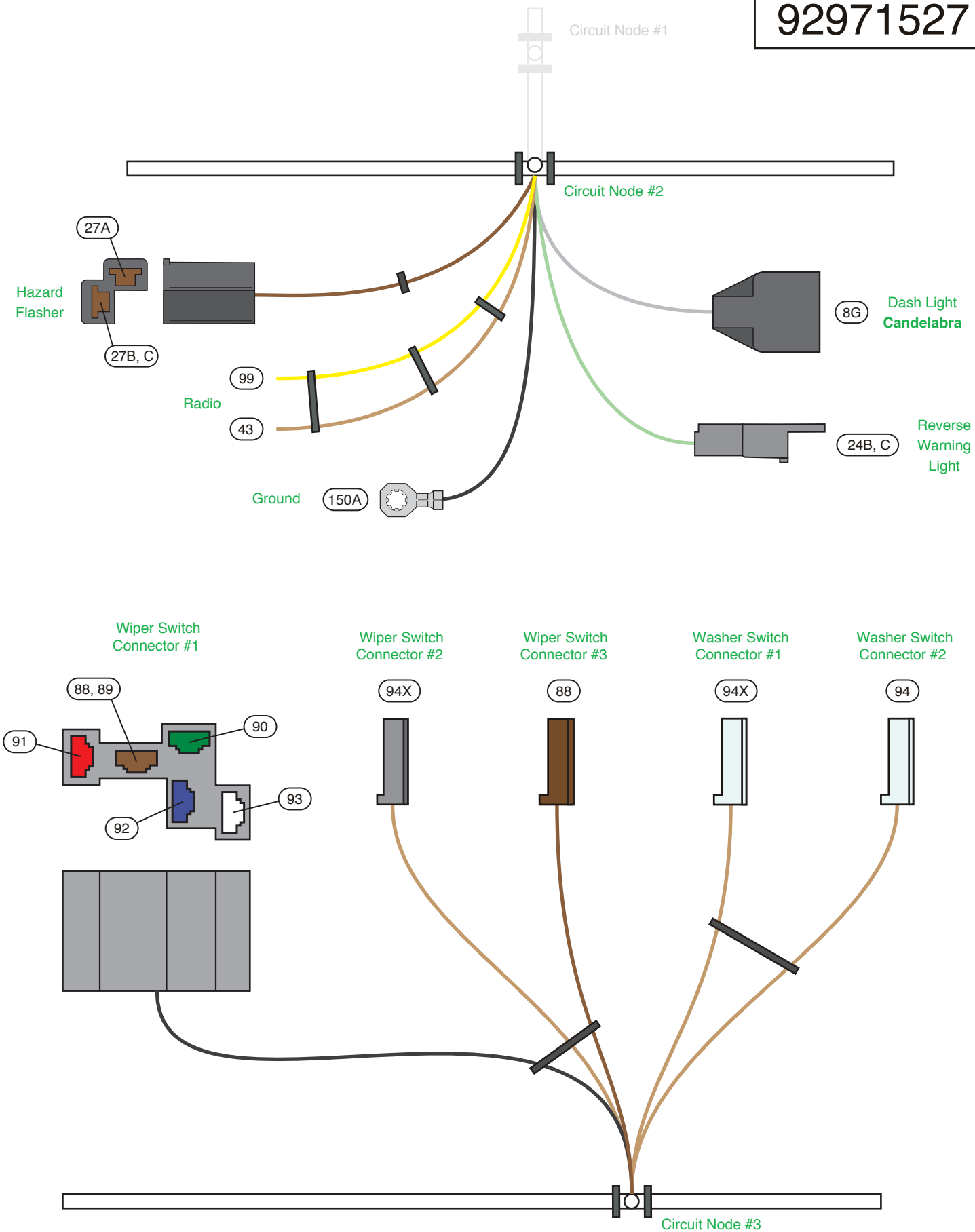

Circuit Node #4

Aftermarket Electric Speedo Ground

Note: Do not attach this ring terminal with any other ground ring terminal; it must be grounded all by itself to a good vehicle ground.

Wire #	Wire Color	Printing	Description
151	Black/White	SPEEDO GROUND	Ground for an Aftermarket Electric Speedometer.

Turn Flasher Connector If you haven't already; plug one of the **Flashers** (included in kit #510557 in Bag G) into this connector. Attach the Flasher to the original metal Flasher Retainer on the Dash, if so equipped.

Wire #	Wire Color	Printing	Description
16A	Purple	TURN SWITCH FEED	12V Ignition feed from the Fuse Block.
16B	Purple	TURN SWITCH FEED	12V feed from the Turn Flasher to the Turn Signal Switch.

Instrument Cluster Connections These connectors will plug to the connectors of the **Gauge Cluster Kit 510636 in Bag H.**

Cluster Connector "A"

Wire #	Wire Color	Printing	Description
4B	Brown	no printing	12V Ignition Accessory feed.
8A, B	Gray	DASH LIGHTS	Illumination Light feed for the Cluster Illumination Lights.
39B	Pink	12V IGNITION	12V Fused Ignition feed.
99A	Yellow	CLOCK BAT	12V Battery feed to the Clock.
150	Black	GROUND	Cluster ground.

Cluster Connector "B"

Wire #	Wire Color	Printing	Description
11B	Light Green	HI BEAM INDICATOR LIGH	Feed to the High Beam Indicator Light.
14C	Light Blue	LEFT DASH IND	Feed for the Left Turn Signal Indicator Light.
15C	Dark Blue	RIGHT DASH IND	Feed for the Right Turn Signal Indicator Light.
30	Tan	GAS GAUGE	Fuel Gauge Signal from the Fuel Tank Sending Unit.
31	Dark Blue	OIL PRESSURE SENDER	Oil Pressure Sender Signal from the Engine.
33B	Tan	BRAKE LIGHT/SWITCH	Brake Warning Light Signal to ground.
35	Dark Green	WATER TEMP SENDER	Water Temperature Sender Signal from the Engine.
121	White	COIL --> TACH	Tachometer feed to the Ignition Coil.

Cluster Connector "C" This connector contains the wires for an **Aftermarket Electric Speedometer**. **NOTE: Wires "400" and "401" must remain twisted together.**

Wire #	Wire Color	Printing	Description
139	Pink/White	SPEEDO POWER	Fused 12V Ignition feed for the Electric Speedometer.
151	Black/White	SPEEDO GROUND	Electric Speedometer Ground.
400	Yellow	VSS GROUND	Vehicle Speed Sensor Ground.
401	Purple	VSS SIGNAL	Vehicle Speed Sensor Signal.
402	Purple/White	VSS POWER	Vehicle Speed Sensor Power.

Panel Dimmer Switch This 3-way connector will plug to your Instrument Panel Light Dimmer Switch.

Wire #	Wire Color	Printing	Description
8A	Gray	DASH LIGHTS	Illumination Light feed from the Panel Dimmer Switch to the Dash Lights.
9B	Brown	PARK LIGHTS	Park Lights/Rear Running Lights feed to the Panel Dimmer Switch.
9C	Brown	REAR RUNNING LIGHTS	Park Lights/Running Lights feed to the Panel Dimmer Switch.
156D, E	White	CTSY GROUND	Dome and Courtesy Lights switched ground.

Headlight Switch Connector Plug this 5-way connector onto the Headlight Switch.

Wire #	Wire Color	Printing	Description
2D	Red	12V BATTERY	12V Battery feed to the Headlight Switch for the Headlights.
9A	Brown	PARK LIGHTS	Feed to the Front Park Lights and the Rear Running Lights.
10	Yellow	DIMMER SW FEED	Feed to the Headlight Dimmer Switch.
40A, B	Orange	12V BATTERY-FUSED	12V Fused Battery feed to the Headlight Switch for the Park Lights, the Courtesy Lights, the Dome Light, and the Trunk Light.

Emergency Flasher Switch (1968-69) **NOTE: This standalone Emergency Flasher Switch is only available on the 1968-69 vehicles. For 1970, this switch is integral with the Steering Column and this 4-way connector will not be used and can be taped back.**

Emergency Flasher Switch Connector (1968-69) Plug the 4-way Emergency Flasher Switch Connector to your Emergency Flasher Switch.

Wire #	Wire Color	Printing	Description
14B, C	Light Blue	LEFT FRONT TURN	Feed to the LH Turn Signal Light and to the Turn Signal Switch.
15B, C	Dark Blue	RIGHT FRONT TURN	Feed to the RH Turn Signal Light and to the Turn Signal Switch
17A	White	BRAKE SW	Feed from the Stop Light Switch.
17C	Light Blue	THIRD BRAKE LIGHT	Feed to the Third Brake Light.
27C	Brown	TURN SW – HAZARD	Feed from the Hazard Flasher.

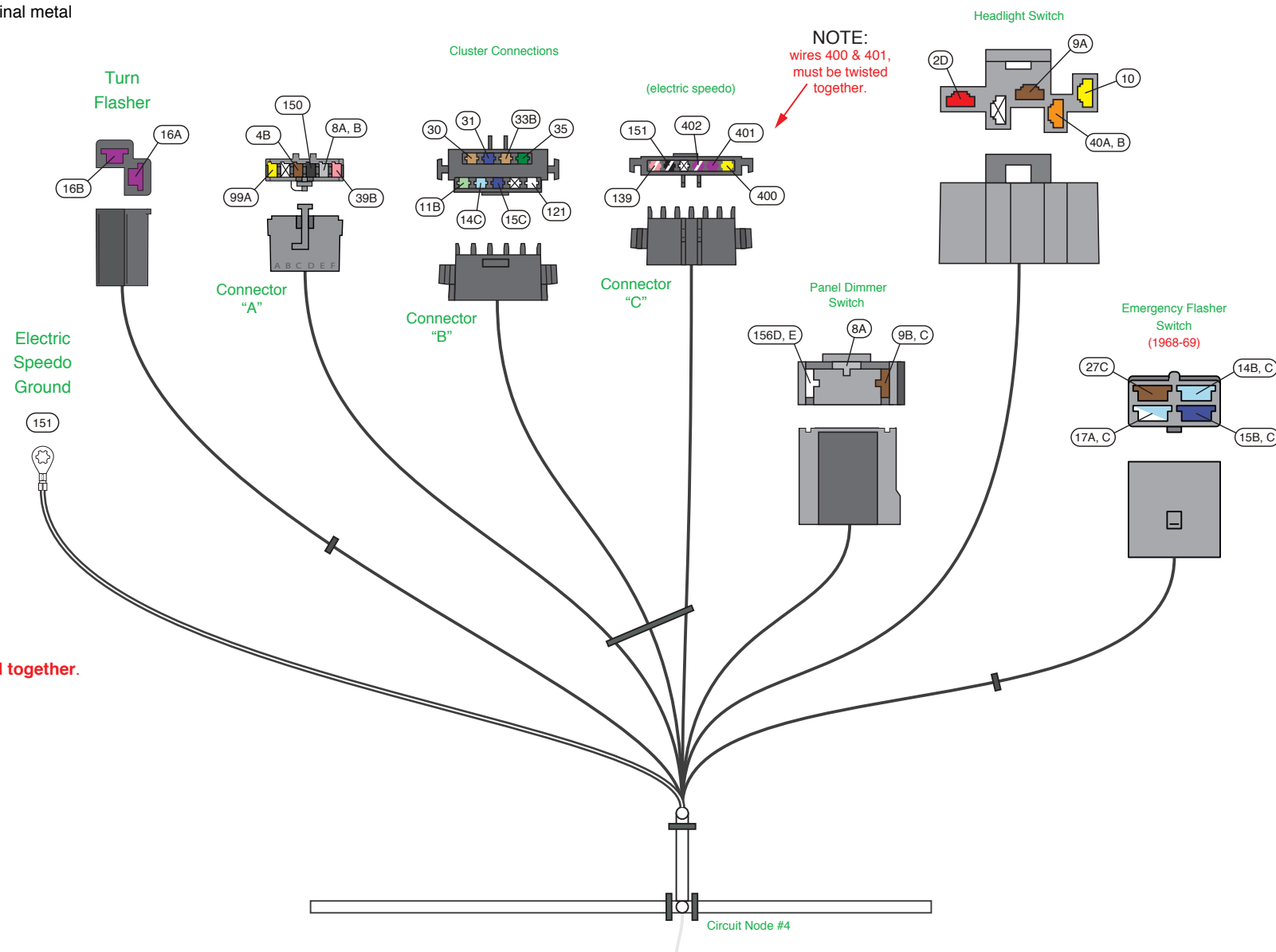

DASH/MAIN HARNESS
1968-70 Mopar B-body
Classic Update Series

510635
4/29/2016 Rev 0.0 JM

Circuit Node #4 (continued)

Left Hand Courtesy Light Plug the 2-way Left Hand Courtesy Light Connector, which is part of the Dash Harness, into one of the **Courtesy Light Jumper Harnesses "B" in Bag G**. Attach the **Courtesy Light Jumper Harness "B"** to the LH lower Outboard IP. **NOTE: This Courtesy Light utilizes a #631 Bulb (which is not included in this kit).**

Wire #	Wire Color	Printing	Description
40B, C	Orange	12V BATTERY – FUSED	12V Battery feed to the LH Courtesy Light.
156C, D	White	CTSY GROUND	Switched ground for the LH Courtesy Light.

Circuit Node #5

Park Brake Switch Connector Plug this male bullet Park Brake Switch connector onto your Park Brake Switch.

Wire #	Wire Color	Printing	Description
33A	Tan	BRAKE LIGHT/SWITCH	Wire from the Brake Warning Light to the Park Brake Switch.

Left Hand Door Jamb Switch Connector Route the Left Hand Door Jamb Switch Connector into the Side Cowl and through the Door Jamb Switch Hole and connect to the Door Jamb Switch. **Note: the Door Jamb Switch 500100 is available for purchase from AAW.** This self tapping Door Jamb Switch will fit into a 3/8"-24 hole. Some 1970 vehicles have a larger hole and this switch will not fit.

Wire #	Wire Color	Printing	Description
156A	White	CTSY GROUND	LH Switched Ground for the Courtesy/ Dome Lights.

Circuit Node #6

Dimmer Switch Connector This wiring branch will route to the **Dimmer Switch 500042 (located in Bag G)**. Attach the 3-way Dimmer Switch connector to the Dimmer Switch and attach to the Floor Pan in the original location.

Wire #	Wire Color	Printing	Description
10	Yellow	DIMMER SW FEED	Feed from the Headlight Switch.
11A	Light Green	HEADLIGHT-HI BEAM	Feed to the High Beam Headlights.
11B	Light Green	HI BEAM INDICATOR	Feed to the High Beam Indicator Light in the Instrument Cluster.
12	Tan	HEADLIGHT-LOW BEAM	Feed to the Low Beam Headlights.

Rear Body Connector This 9-way connector will plug into the 9-way connector of the **Rear Body Harness Kit 510639 in Bag M**.

Wire #	Wire Color	Printing	Description
9C	Brown	REAR RUNNING LIGHTS	Feed for the Tail Lights, the License Light, the Rear Running Lights, and the Rear Side Marker Lights.
17C	Light Blue	THIRD BRAKE LIGHT	Feed for an aftermarket Third Brake Light.
18	Yellow	LEFT REAR TURN	Feed to the Left Rear Stop and Turn Lights.
19	Dark Green	RIGHT REAR TURN	Feed to the Right Rear Stop and Turn Lights.
24C	Light Green	BACK UP LT SW --> LIGHTS	Feed from the Back-up Light Switch to the Back-up Lights.
30	Tan	GAS GAUGE	Fuel Tank Sender.
40D	Orange	12V BATTERY-FUSED	12V Battery feed to the Trunk Light.
156A, B	White	CTSY GROUND	Switched Ground for the Dome/Courtesy Lights.

Dome Light Connector This 2-way connector will connect to the **Dome Light Jumper Harness** which is included in the **Rear Body Harness Kit 510639 in Bag M**.

Wire #	Wire Color	Printing	Description
40C, D	Orange	12V BATTERY-FUSED	Feed to the Dome Light.
156B, C	White	CTSY GROUND	Switched Ground for the Dome/Courtesy Lights.

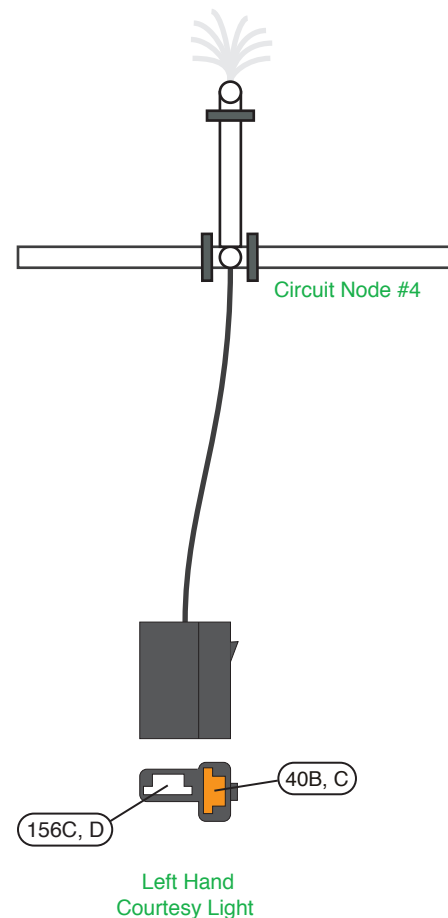

NOTE: The Courtesy Light Jumper Harness, from Page 5, that plugs onto the connector at Node #4 on this page, uses a # 631 bulb (not included with this kit). They may be purchased at any auto parts store.

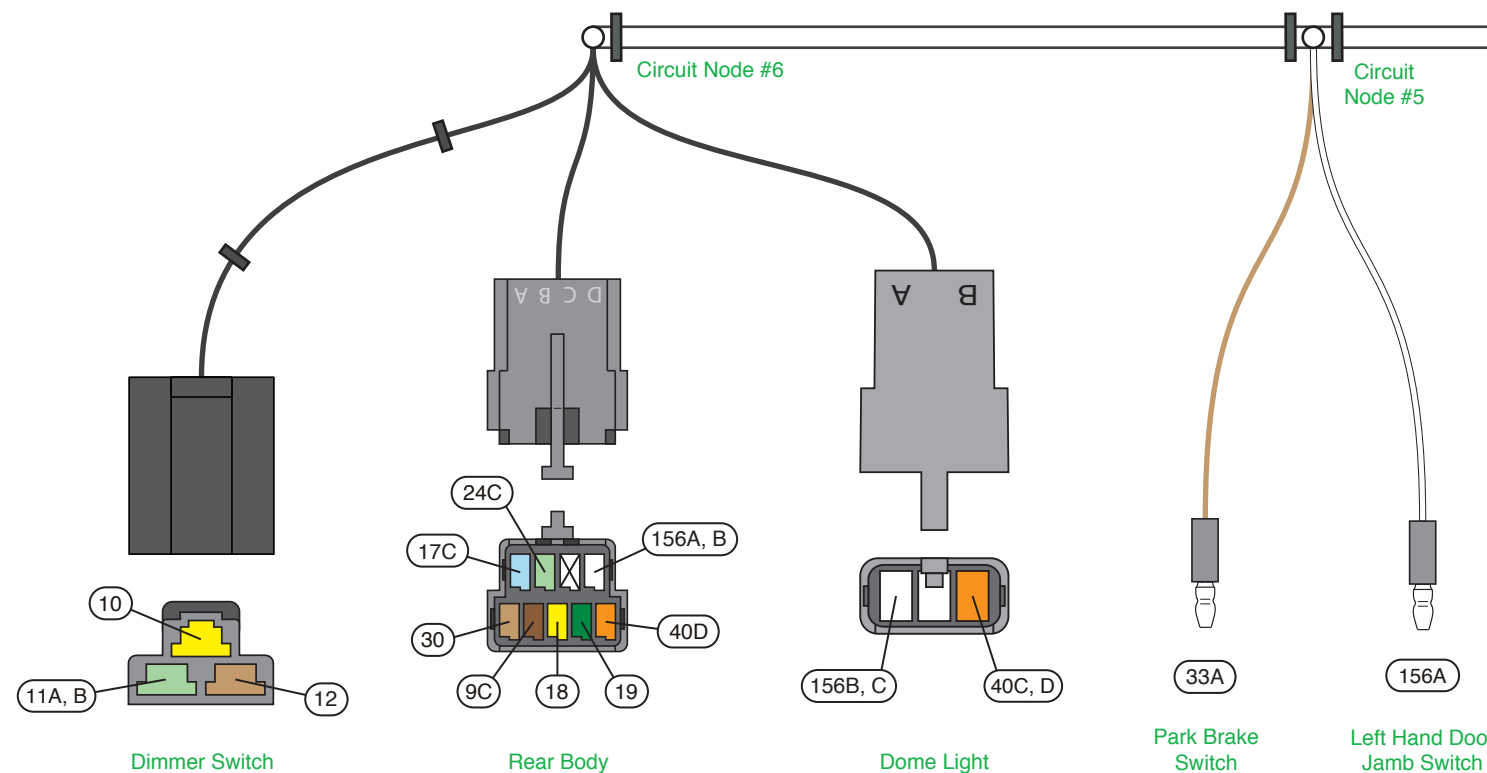

510635
92971527
Rev. 0.0
4/29/2016

Circuit Node #7

Ash Tray Light Connector Connect the Ash Tray Light female bullet connector to the Ash Tray Light pigtail.

Wire #	Wire Color	Printing	Description
8E, F	Gray	DASH LIGHTS	Dash Light feed to the Ash Tray Light pigtail.

Horn Relay Connector If you haven't already; plug the **Horn Relay** (included in kit #510557 in Bag G) into this connector.

Wire #	Wire Color	Printing	Description
2C	Red	12V BATTERY	12V Battery feed to the Horn Relay.
28	Black	HORN RELAY GROUND	Relay ground circuit to the Steering Column Horn Switch.
29	Dark Green	HORN	Feed to the Horns.

Floor Console Connector This connector is provided if you have the **Floor Console** option or have a **1968** vehicle with the Back-up Light Switch on the Steering Column.

Wire #	Wire Color	Printing	Description
8F, G	Gray	DASH LIGHTS	Dash Light feed to the Floor Console PRNDL Light.
24A, B	Light Green	BACK UP LT SW --> LIGHTS	Feed from the Floor Console Back-up Light Switch to the Back-up Lights.
39A, B	Pink	12V IGNITION	Fused 12V Ignition feed to the Floor Console Back-up Light Switch.
40F, H	Orange	12V BATTERY-FUSED	Fused 12V Battery feed to the Floor Console Courtesy Lights.
150, 150A	Black	GROUND	Ground for the Floor Console PRNDL Light.
156E, F	White	CTSY GROUND	Switched ground for the Floor Console Courtesy Lights.

Floor Console Wiring Kit If you have a Floor Console obtain the **Floor Console Wiring Kit 510640 in Bag G** and plug it into the 6-way Floor Console Connector. Route the Floor Console Harness under the carpet and alongside the Floor Console. Tuck the harness under the carpet and make the connections to the Floor Console components from the rear of the Floor Console. See the Floor Console Kit Instructions for additional details. The Floor Console Wiring Harness will connect to the Courtesy Lights, the Automatic Transmission PRNDL Illumination Light, and the Back-up Light Switch (**1968**).

1968 Automatic Transmission Back-up Light Switch Jumper Harness If you have a **1968** car with the Automatic Transmission Shifter on the Steering Column, you will need to plug the **1968 A/T Back-up Light Switch (Steering Column mounted) Jumper Harness "D" in Bag G** to the Floor Console Connector and plug the other end of the Jumper to the Back-up Light Switch on the Steering Column. The 2-way mating connector "L" and terminals "M" have been provided (in Loose Piece Kit 92971528) to crimp on to the Back-up Light Switch Pigtail.

Circuit Node #8

Cigar Lighter Connector Connect the Cigar Lighter female bullet connector to the Cigar Lighter.

Wire #	Wire Color	Printing	Description
40G	Orange	12V BATTERY-FUSED	Fused 12V Battery feed to the Cigar Lighter.

Heater Switch Illumination Light Connector This female bullet connector will plug into the orange wire pigtail from the Heater Control Assembly Illumination Light.

Wire #	Wire Color	Printing	Description
8D, E	Gray	DASH LIGHTS	Illumination Light feed wire for the Heater Control Assembly Light.

Heater Switch Connector This 1-way connector will plug into the 1-way connector from the Heater Control Assembly. Connector "K" and terminal "M" are provided if you need to replace the original connector on your Heater Control Assembly pigtail.

Wire #	Wire Color	Printing	Description
50	Brown	HEATER/AC FEED	12V feed from the Fuse Block.

Heater Blower Motor Resistor **Note: the pigtail with the 3-way connector from the original Heater Switch Control Assembly will plug into the Heater Blower Motor Resistor. There are no wires provided in this kit for the Heater Blower Motor Resistor connection.**

Map Light Connector This 2-way connector will plug into the optional Map Light. **Note: the Map Light Wiring Kit 510430 is available for purchase from American Autowire.**

Wire #	Wire Color	Printing	Description
40E, F	Orange	12V BATTERY-FUSED	Fused 12V Battery feed to the Map Light.
156F, G	White	CTSY GROUND	Switched ground for the Map Light.

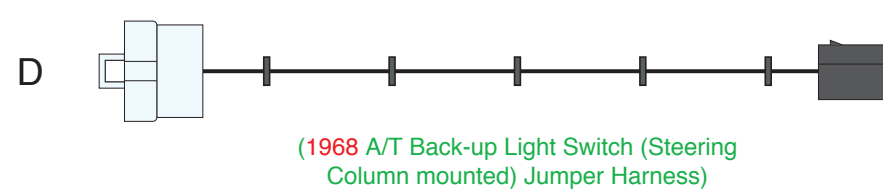
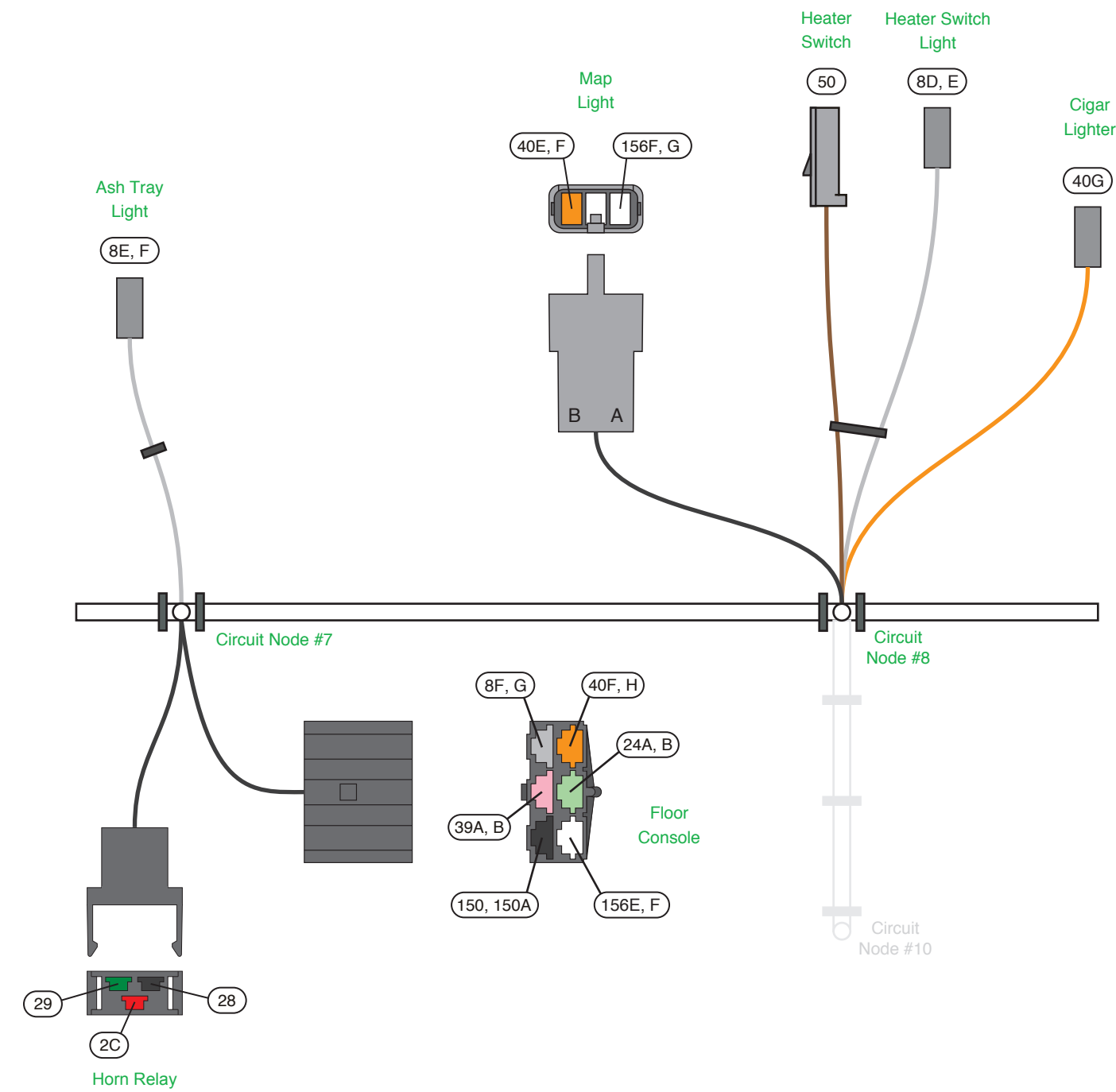

DASH/MAIN HARNESS

1968-70 Mopar B-body
Classic Update Series

510635
4/29/2016 Rev 0.0 JM

92971527

Circuit Node #9

Fuse Block Attachment The Fuse Block will be located in the Glove Box. Provide a clearance opening at the left end of the Glove Box Liner and slide the Fuse Block into the Glove Box. Attach the Fuse Block to the floor of the Glove Box with three screw, nut and washers "N" (see Photos #3 and #4).

Accessory Connector Use the provided 6-way empty connector, which is attached to the 6-way Accessory connector on the Dash Harness, and terminals "H" and "J" (included in Parts Kit 92971528 in Bag G) to add power wires (not provided) for the following optional systems:

1968-70 B-Body Accessory Connector

Wire #	Wire Color	Printing	Fuse #	Fuse Block Cover	Fuse rating	Description
100	Orange	no printing	7	Hazard	15A	Battery feed for Hazard or Audio Systems.
103	Tan	FUEL PUMP	10	Fuel Pump	20A	Ignition feed for an Electric Fuel Pump.
104	Orange	POWER SEATS	2	Pwr Seats	30A	Battery feed for Power Seats.
105	Red	POWER LOCKS	8	Pwr Locks	20A	Battery feed for Power Locks.
106	Pink	POWER WINDOWS	15	Pwr Window	30A	Accessory feed for Power Windows.
107	Orange	12V BATTERY FUSED	1	Bat-Spare	30A	Battery feed for options.

Circuit Node #10

Right Hand Courtesy Light Plug the 2-way Right Hand Courtesy Light Connector, which is part of the Dash Harness, into one of the Courtesy Light Jumper Harnesses "B" in Bag G. Attach the Courtesy Light Jumper Harness "B" to the RH Lower Outboard IP. **NOTE: This Courtesy Light utilizes a #631 Bulb (which is not included in this kit).**

Wire #	Wire Color	Printing	Description
40J, K	Orange	12V BATTERY – FUSED	12V Battery feed to the RH Courtesy Light.
156G, H	White	CTSY GROUND	Switched ground for the RH Courtesy Light.

Glove Compartment Light Connector Plug the female bullet Glove Compartment Light connector to the Glove Compartment Switch/Light Pigtail.

Wire #	Wire Color	Printing	Description
40K	Orange	12V BATTERY – FUSED	12V Battery feed to the Glove Compartment Light.

Right Hand Door Jamb Switch Connector Route the Right Hand Door Jamb Switch Connector into the Side Cowl and through the Door Jamb Switch Hole and connect to the Door Jamb Switch **Note: the Door Jamb Switch 500100 is available for purchase from AAW.** This self tapping Door Jamb Switch will fit into a 3/8"-24 hole. Some 1970 vehicles have a larger hole and this switch will not fit.

Wire #	Wire Color	Printing	Description
156H	White	CTSY GROUND	RH Switched Ground for the Courtesy/ Dome Lights.

92971527

Mating connector is plugged into Accessory Connector

Photo #3



1968

Photo #4



1970

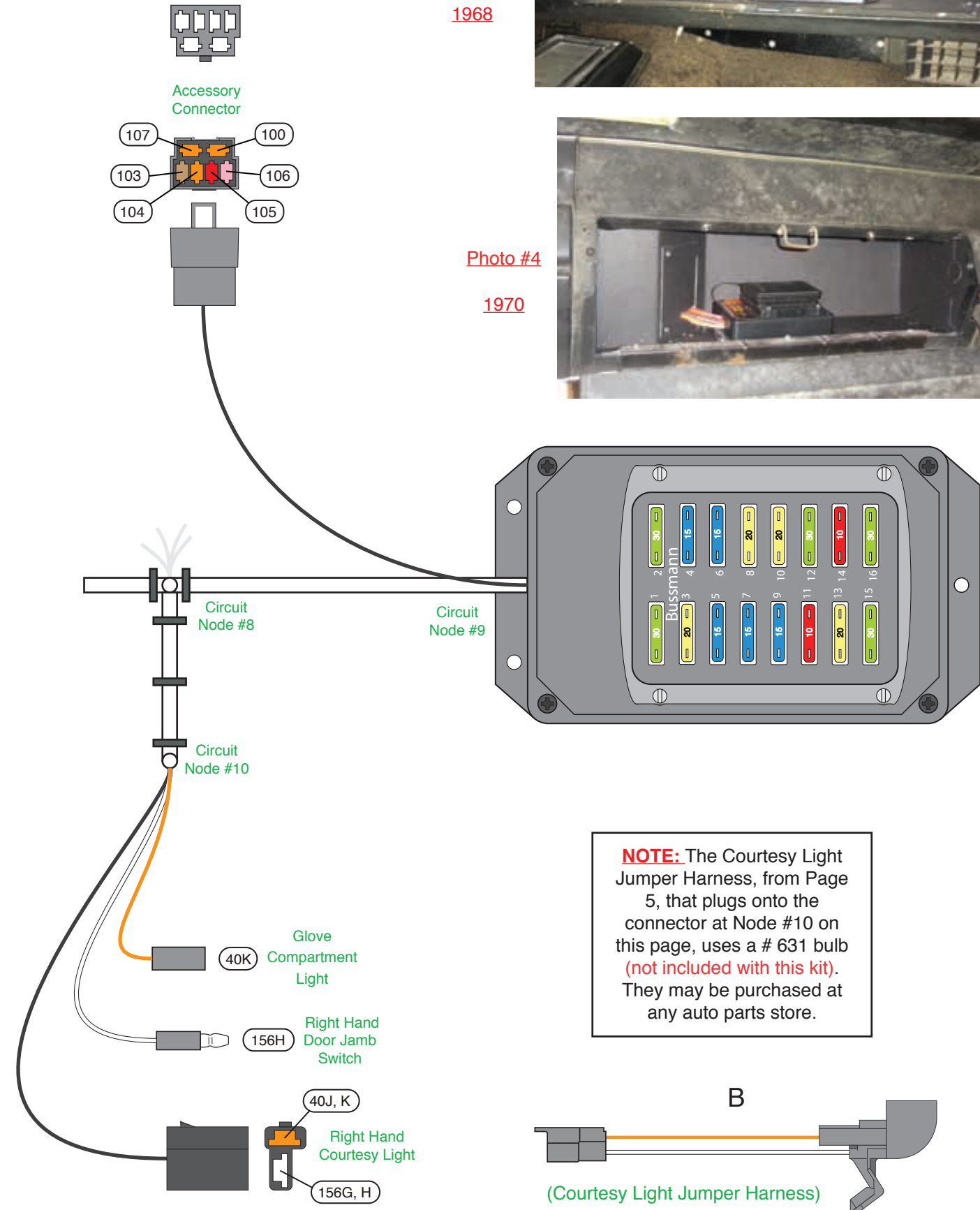

NOTE: The Courtesy Light Jumper Harness, from Page 5, that plugs onto the connector at Node #10 on this page, uses a # 631 bulb (not included with this kit). They may be purchased at any auto parts store.

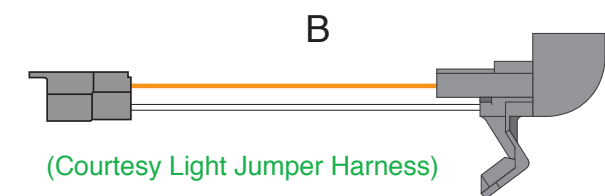

510635
92971527
Rev. 0.0
4/29/2016

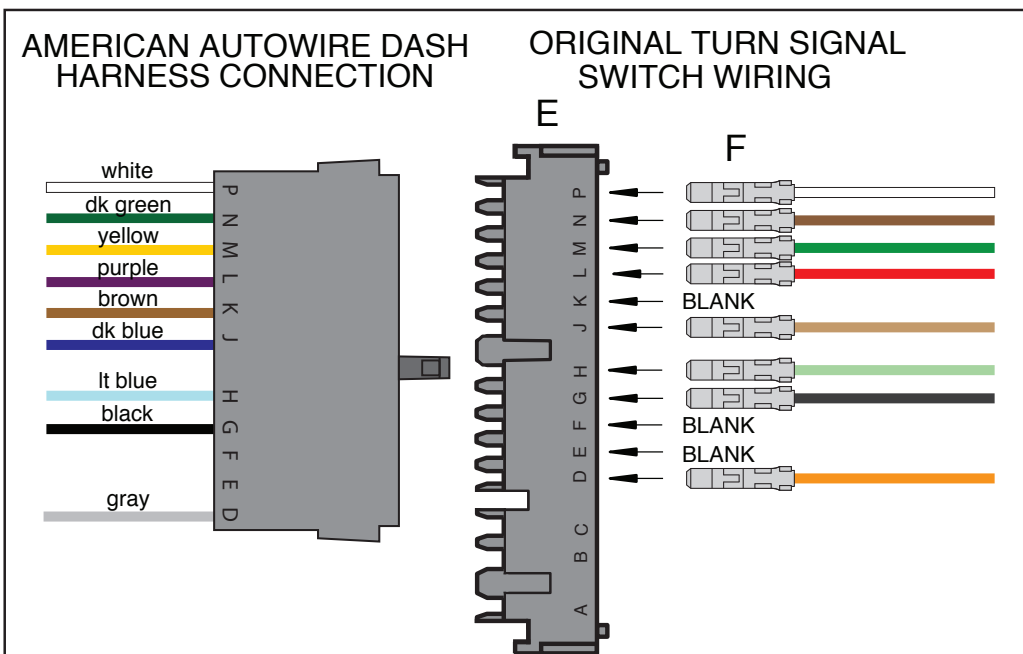

DIAGRAM 'A' - AAW Turn Signal Switch Wires to Stock 1968-69 Steering Columns.

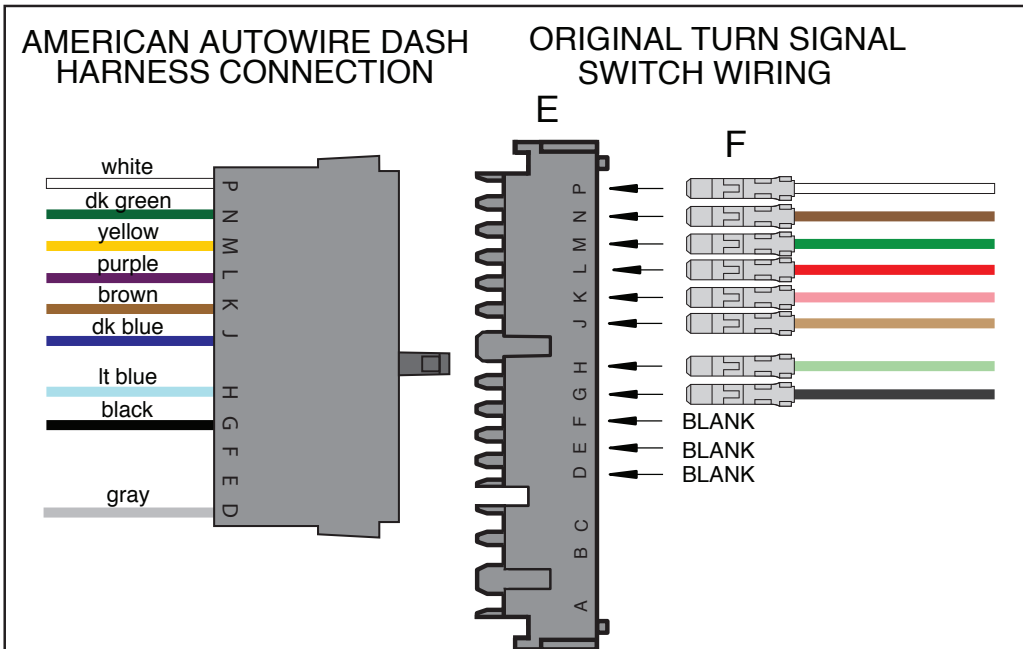

DIAGRAM 'B' - AAW Turn Signal Switch Wires to Stock 1970 Steering Columns.

“Table B”

AAW Turn Signal Switch wires to stock 1968-70 Mopar B-body Turn Signal Switch

AAW Wire #	AAW Wire Color	AAW Wire Printing	Connector Cavity AAW	B-Body Turn Signal Switch Wire Color	Aftermarket Turn Signal Switch Wire Color
17B	White	Brake SW	P	White	White
19	Dark Green	Right Rear Turn	N	Brown	Brown
18	Yellow	Left Rear Turn	M	Dark Green	Dark Green
16B	Purple	Turn Switch Feed	L	Red	Red
27B	Brown	Turn SW – Hazard	K	None (1968-69) or Pink (1970)	None or Pink
15A, B	Dark Blue	Right Front Turn	J	Tan	Tan or Gray
14A, B	Light Blue	Left Front Turn	H	Light Green	Light Green or Black/Green
28	Black	Horn Relay Ground	G	Black	Black
None	None	None	F	None	None
None	None	None	E	None	None
8C, D	Gray	DASH LIGHTS	D	Orange (1968-69) or None (1970)	Orange

Note: Remove the original Turn Signal Switch Connector and replace it with the AAW 14-way connector “E”. Crimp on terminal “F” to each of the original Turn Signal Switch wires and plug them into connector “E” (see Parts Kit 92971528). Use “Table B” above to align the wires. Also, for all of the vehicles, the Steering Column Horn Button switches ground for the Horn Relay, which then switches power to the Horns, similar to the AAW design.

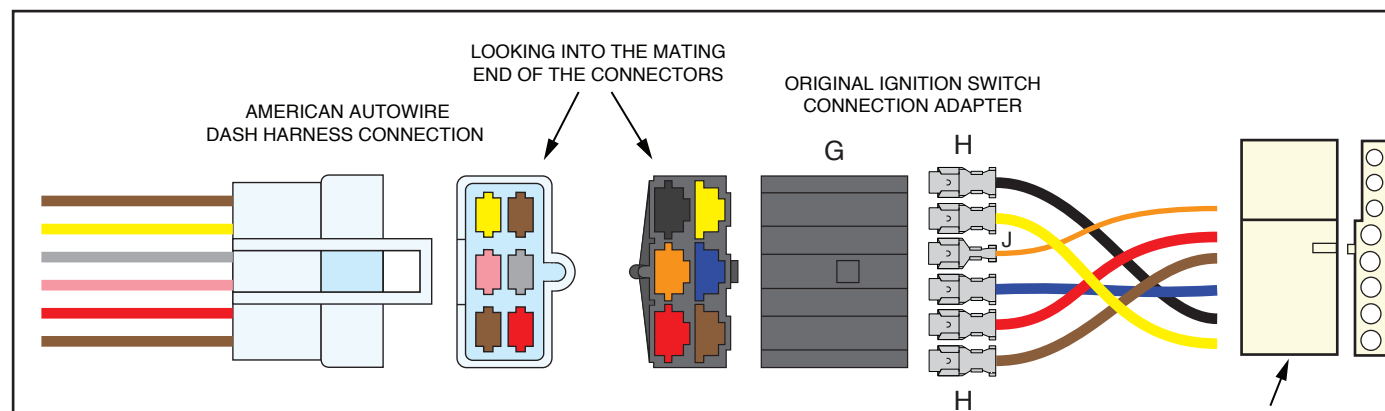

“Table A”

Mopar B-Body 1968-70 Ignition Switch Wires

AAW Wire #	AAW Wire Color	AAW Wire Printing	Wire Description	B-Body Wire Color
5	Yellow	no printing	Start	Yellow
4A, B	Brown (double)	IGNITION SW ACCY	12V Accessory Feed	Black
3A	Pink	IGNITION FEED	12V Ignition Feed	Dark Blue
8B, C	Gray (double)	DASH LIGHTS	Illumination Light	Orange
7	Brown	no printing	Resistor Bypass	Brown
2B	Red	12V BATTERY	12V Battery Feed	Red

Note: Be sure to align the B-Body wire with the corresponding AAW wire in the 6-way connector “G”. Crimp on terminal “J” for the thinner wires and terminal “H” for the thicker wires (see Parts Kit 92971528). The two additional thin red wires in the original stock Ignition Switch Connector Pigtail are for the Key-in-Ignition Warning Buzzer and will not be used and can be taped back.

DASH/MAIN HARNESS

1968-70 Mopar B-body Classic Update Series

510635

4/29/2016 Rev 0.0 JM

92971527